



Hybrid

Emergency Response Guide



Foreword

In December 2011, Toyota released the PriusC petrol-electric hybrid vehicle. To educate and assist emergency responders in the safe handling of the PriusC hybrid technology, Toyota published this PriusC Emergency Response Guide.

High voltage electricity powers the electric motor, generator, air conditioning compressor and inverter/converter. All other automotive electrical devices such as the headlights, radio, and gauges are powered from a separate 12 Volt auxiliary battery. Numerous safeguards have been designed into the PriusC to help ensure the high voltage, approximately 144 Volt, Nickel Metal Hydride (NiMH) Hybrid Vehicle (HV) battery pack is kept safe and secure in an accident.

The PriusC utilises the following electrical systems:

- Maximum 520 Volts AC
- Nominal 144 Volts DC
- Maximum 27 Volts AC
- Nominal 12 Volts DC

PriusC Features:

- A boost converter in the inverter/converter that boosts the available voltage to the electric motor to 520 Volts.
- A high voltage Hybrid Vehicle (HV) battery pack rated at 144 Volts.
- A high voltage motor driven Air Conditioning (A/C) compressor rated at 144 Volts.
- A body electrical system rated at 12 Volts, negative chassis ground.
- Supplemental Restraint System (SRS) - dual stage frontal airbags, a driver knee airbag, front seat side airbags, front seat cushion airbags, side curtain airbags and front seat belt pretensioners.
- An Electric Power Steering (EPS) assist motor rated at 27 Volts.

High voltage electrical safety remains an important factor in the emergency handling of the PriusC Hybrid Synergy Drive. It is important to recognise and understand the disabling procedures and warnings throughout the guide.

Additional topics in the guide include:

- PriusC identification.
- Major Hybrid Synergy Drive component locations and descriptions.
- Extrication, fire, recovery, and additional emergency response information.
- Roadside assistance information.

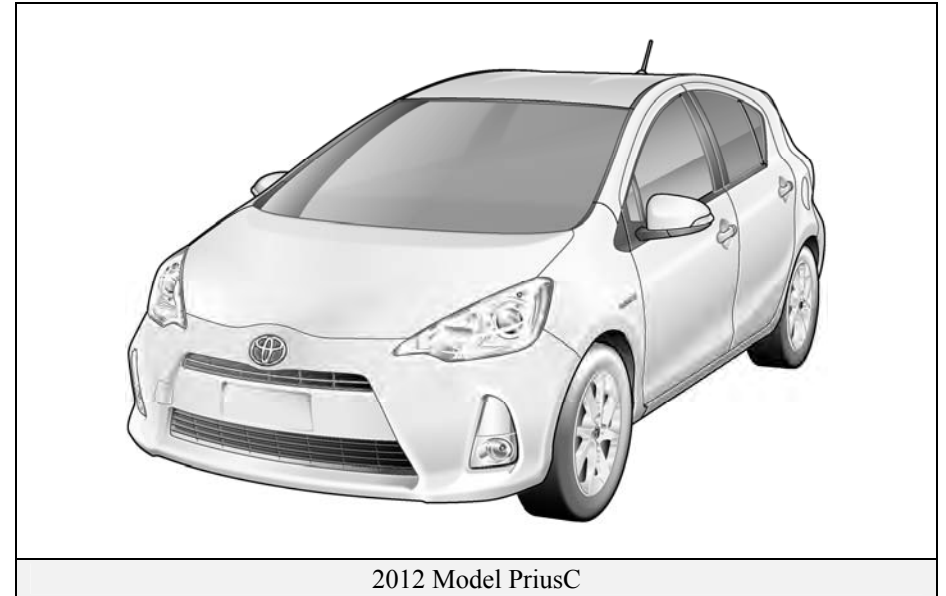

This guide is intended to assist emergency responders in the safe handling of a PriusC vehicle during an incident.

NOTE:

Emergency Response Guides for Toyota hybrid vehicles may be viewed at <http://techinfo.toyota.com>.

Table of Contents	Page
About the PriusC	1
PriusC Identification	2
Hybrid Synergy Drive Component Locations & Descriptions	5
Smart Entry and Start System	8
Hybrid Synergy Drive Operation	10
Hybrid Vehicle (HV) Battery Pack	11
27 Volt System	12
Low Voltage Battery	13
High Voltage Safety	14
SRS Airbags & Seat Belt Pretensioners	15
Emergency Response	17
Extrication	17
Fire	23
Overhaul	24
Recovering/Recycling of NiMH HV Battery Pack	24
Spills	25
First Aid	25
Submersion	26
Roadside Assistance	27
Material Safety Data Sheet	30

About the PriusC

The PriusC 5-door hatchback joins the Prius, Camry Hybrid as a hybrid model for Toyota. Hybrid Synergy Drive means that the vehicle contains a petrol engine and an electric motor for power. The two hybrid power sources are stored on board the vehicle:

1. Petrol stored in the fuel tank for the petrol engine.
2. Electricity stored in a high voltage Hybrid Vehicle (HV) battery pack for the electric motor.

The result of combining these two power sources is improved fuel economy and reduced emissions. The petrol engine also powers an electric generator to charge the battery pack; unlike a pure all electric vehicle, the PriusC never needs to be charged from an external electric power source.

Depending on the driving conditions one or both sources are used to power the vehicle. The following illustration demonstrates how the PriusC operates in various driving modes.

- ❶ During light acceleration at low speeds, the vehicle is powered by the electric motor. The petrol engine is shut off.
- ❷ During normal driving, the vehicle is powered mainly by the petrol engine. The petrol engine also powers the generator to charge the battery pack and to drive the electric motor.

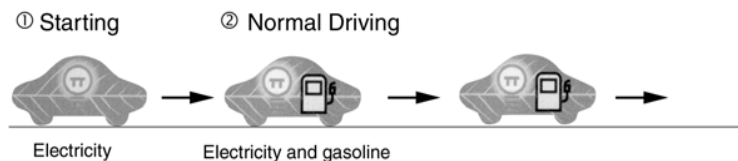

- ❸ During full acceleration, such as climbing a hill, both the petrol engine and the electric motor power the vehicle.
- ❹ During deceleration, such as when braking, the vehicle regenerates kinetic energy from the front wheels to produce electricity that charges the battery pack.
- ❺ While the vehicle is stopped, the petrol engine and electric motor are off, however the vehicle remains on and operational.

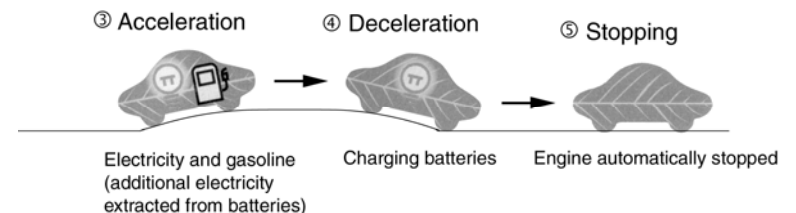

PriusC Identification

In appearance, the PriusC is a 5-door hatchback. Exterior, interior, and engine compartment illustrations are provided to assist in identification.

The alphanumeric 17 character Vehicle Identification Number (VIN) is provided in the right side floor and on the left side B pillar.

Example VIN: JTDKD3B30C3000101

A PriusC is identified by the first 8 alphanumeric characters **JTDKD3B3**.

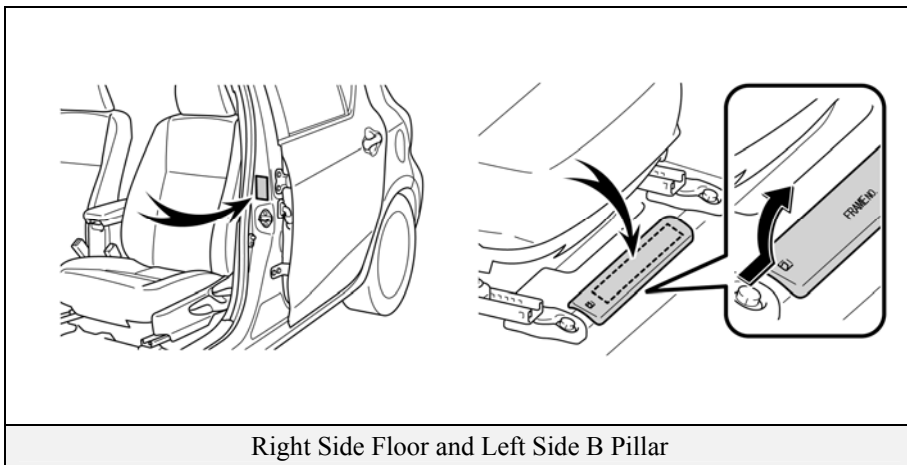

Exterior

- 1 **PRIUSC** and **HYBRID SYNERGY DRIVE** logos on the back door.
- 2 **HYBRID** logo on each front fender.
- 3 Petrol fuel filler door located on left side rear quarter panel.

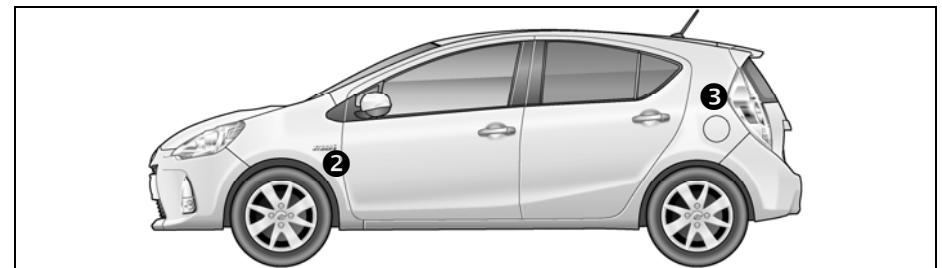

Exterior Left Side View

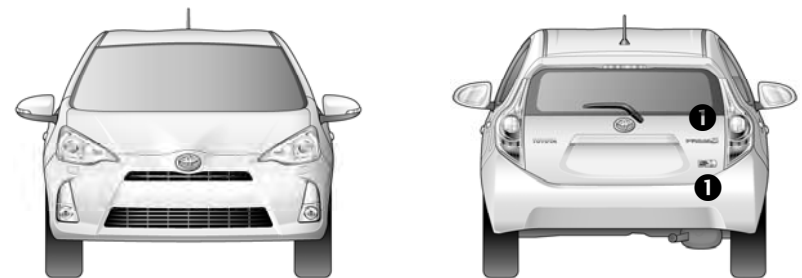

Exterior Front and Rear View

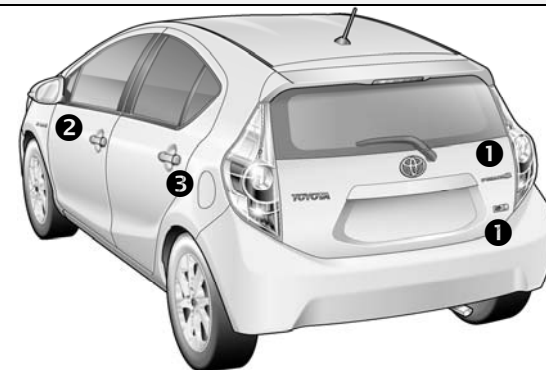

Exterior Rear and Left Side View

PriusC Identification (Continued)

Interior

- ④ Instrument cluster (speedometer, **READY** indicator, hybrid system indicators, warning lights) located in center of the dash and near the base of the windshield.

NOTE:

If the vehicle is shut off, the instrument cluster gauges will be “blacked out”, not illuminated.

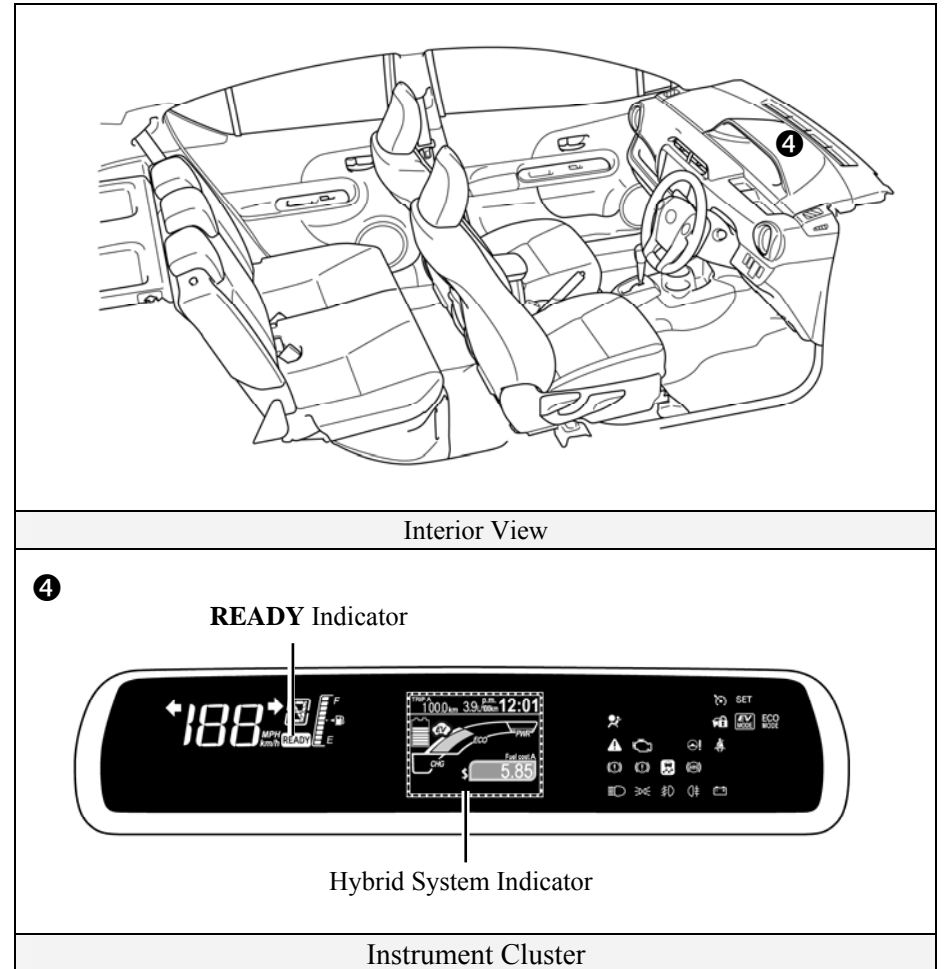

PriusC Identification (Continued)

Engine Compartment

- ⑤ 1.5-litre aluminium alloy petrol engine.
- ⑥ Logo on the plastic inverter cover.

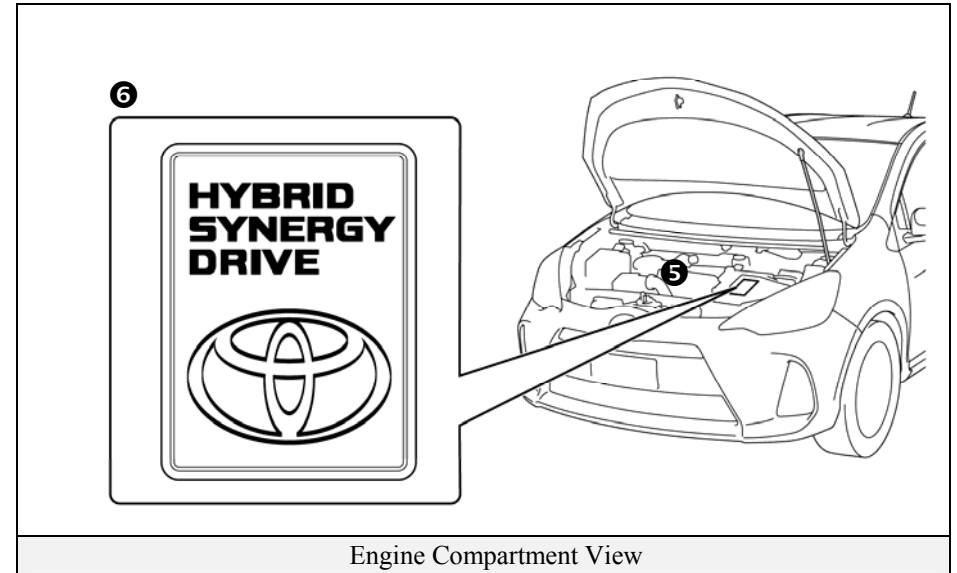

Hybrid Synergy Drive Component Locations & Descriptions

Component	Location	Description
12 Volt 1 Auxiliary Battery	Under Right Side Rear Seat	A lead-acid battery that supplies power to the low voltage devices.
Hybrid 2 Vehicle (HV) Battery Pack	Mounted to Cross Member Under Rear Seat	144 Volt Nickel Metal Hydride (NiMH) battery pack consisting of 20 low voltage (7.2 Volt) modules connected in series.
Power 3 Cables	Undercarriage and Engine Compartment	Orange coloured power cables carry high voltage Direct Current (DC) between the HV battery pack, inverter/converter, and A/C compressor. These cables also carry 3-phase Alternating Current (AC) between the inverter/converter, electric motor, and generator.
Inverter/ Converter 4	Engine Compartment	Boosts and inverts the high voltage electricity from the HV battery pack to 3-phase AC electricity that drives the electric motor. The inverter/converter also converts AC electricity from the electric generator and electric motor (regenerative braking) to DC that charges the HV battery pack.
Petrol 5 Engine	Engine Compartment	Provides two functions: 1) Powers vehicle. 2) Powers generator to charge the HV battery pack. The engine is started and stopped under control of the vehicle computer.
Electric 6 Motor	Engine Compartment	3-phase high voltage AC permanent magnet electric motor contained in the front transaxle. It is used to power the front wheels.
Electric 7 Generator	Engine Compartment	3-phase high voltage AC generator that is contained in the transaxle and charges the HV battery pack.
A/C Compressor (with Inverter) 8	Engine Compartment	3-phase high voltage AC electrically driven motor compressor.

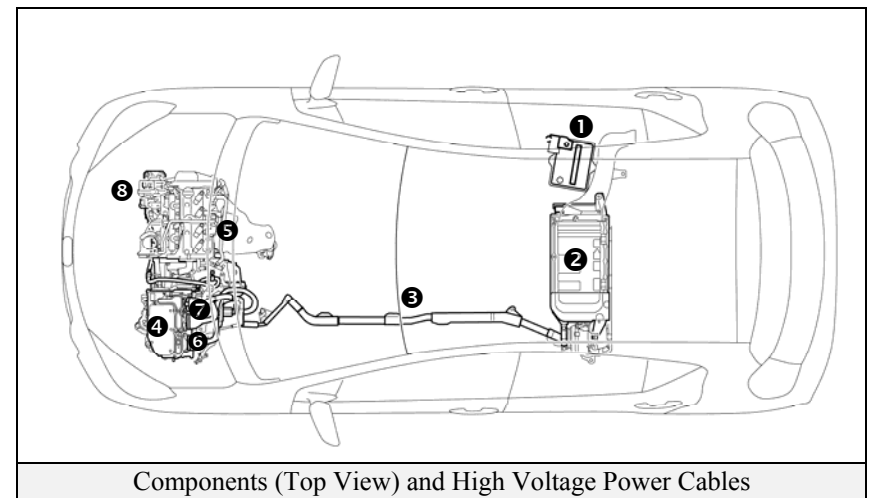
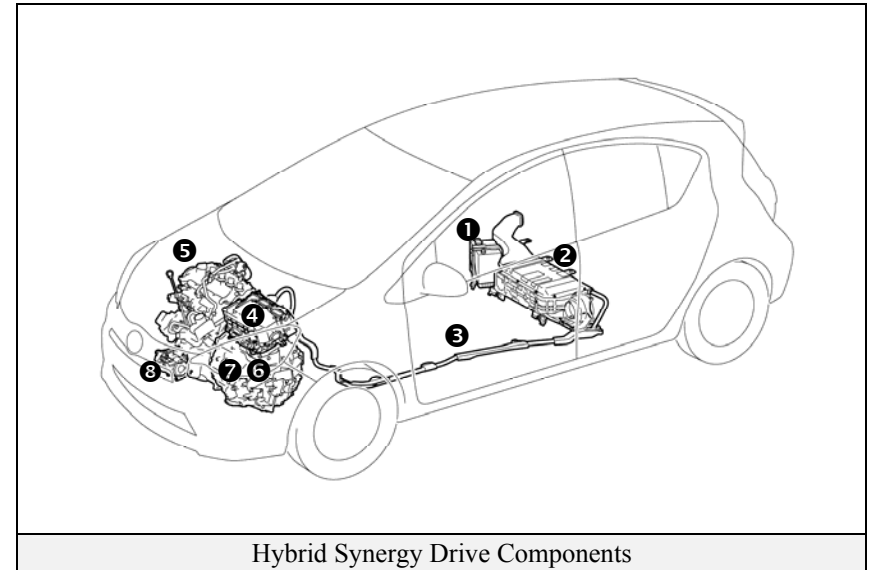

Hybrid Synergy Drive Component Locations & Descriptions (Continued)

Component	Location	Description
Fuel Tank and Fuel Line ⑨	Undercarriage and Center	The fuel tank provides petrol via a fuel line to the engine. The fuel line is routed under the center of vehicle.

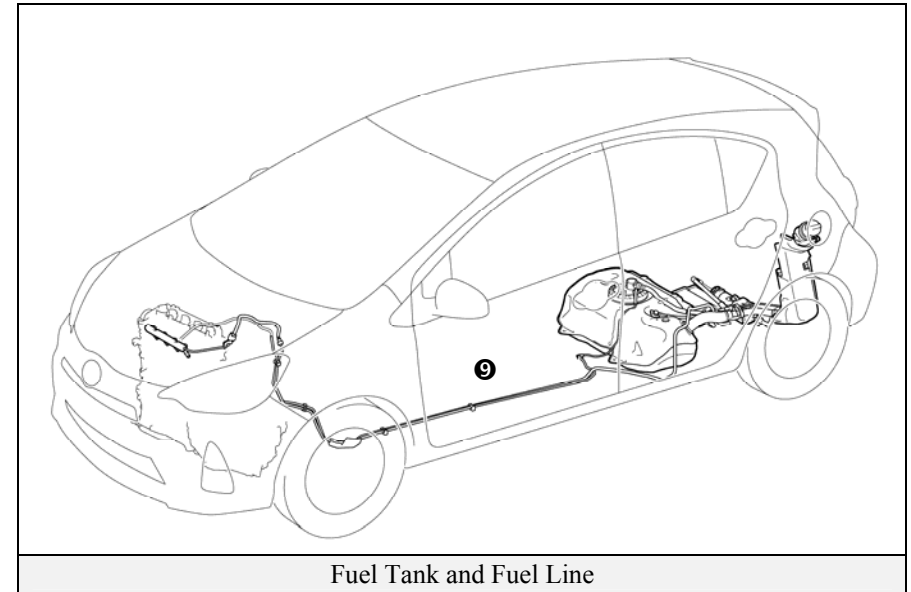

Hybrid Synergy Drive Component Locations & Descriptions (Continued)

Key Specifications:

Petrol Engine:	54 kW, 1.5-litre Aluminium Alloy Engine
Electric Motor:	45 kW, Permanent Magnet Motor
Transmission:	Automatic Only (electrically controlled continuously variable transaxle)
HV Battery:	144 Volt Sealed NiMH-Battery
Curb Weight:	1,132 kg
Fuel Tank:	36.0 litres
Frame Material:	Steel Unibody
Body Material:	Steel Panels
Seating Capacity:	5 passenger

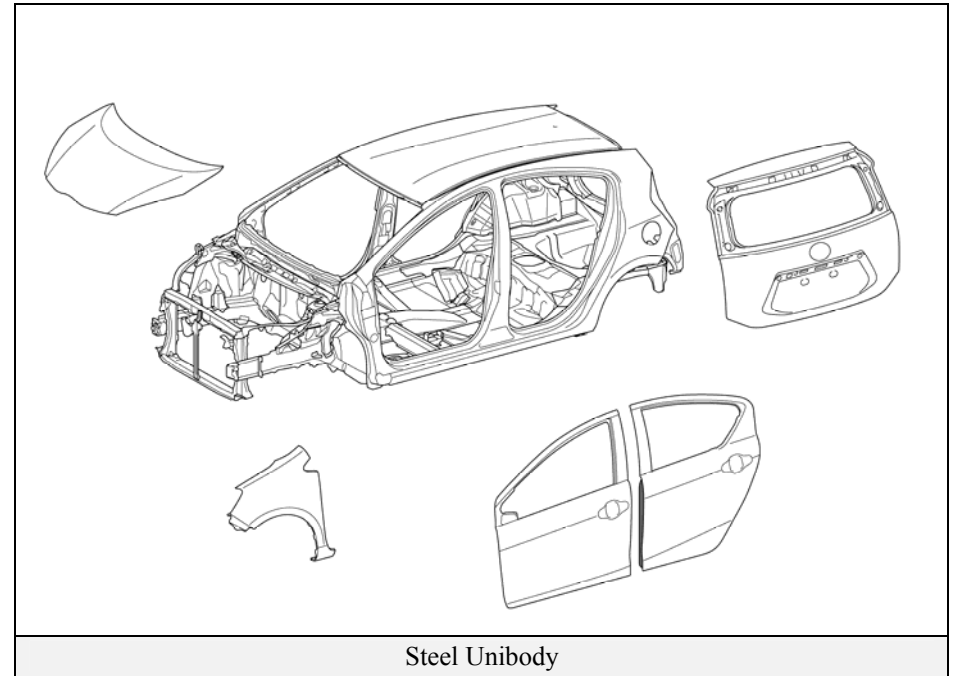

Smart Entry and Start System

The PriusC smart entry and start system consists of a smart key transceiver that communicates bi-directionally, enabling the vehicle to recognise the smart key in proximity to the vehicle. Once recognised, the smart key will allow the user to lock and unlock the doors without pushing smart key buttons, and start the vehicle without inserting it into an ignition switch.



Smart key features:

- Passive (remote) function to lock/unlock the doors and start the vehicle.
- Wireless transmitter buttons to lock/unlock all 5 doors.
- Hidden metal cut key to lock/unlock the doors.

Door (Lock/Unlock)

There are several methods available to lock/unlock the doors.

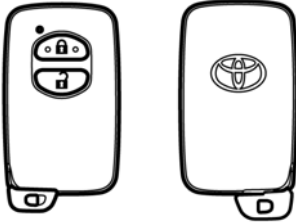
- Pushing the smart key lock button will lock all doors. Pushing the smart key unlock button unlocks all doors.
- Touching the sensor on the backside of the driver door exterior handle, with the smart key in proximity to the vehicle, unlocks all doors. Touching the sensor on the backside of the front passenger door exterior handle, with the smart key in proximity to the vehicle, unlocks all doors. Touching the lock touch sensor on either front door, or pushing the back door lock button will lock all doors.
- Inserting the hidden metal cut key in the driver door lock and turning clockwise unlocks all doors. To lock all doors turn the key counter clockwise. Only the driver door contains an exterior door lock for the metal cut key.

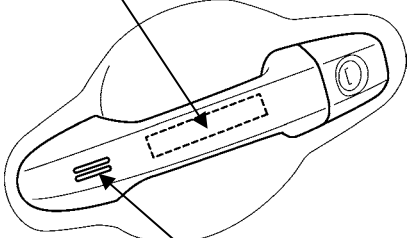
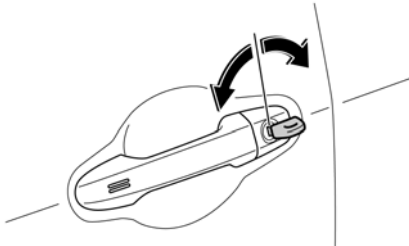
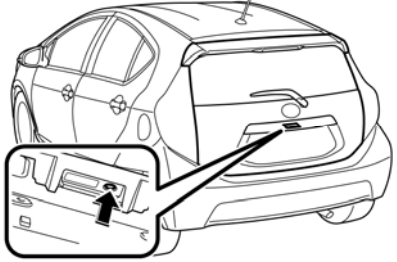
	
Smart Key (Fob)	Hidden Metal Cut Key for Door Lock
	
Driver Door Unlock Touch Sensor and Lock Touch Sensor	Use the Hidden Metal Cut Key
	
Back Door Lock Button	

Smart Entry and Start System

Vehicle Starting/Stopping

The smart key has replaced the conventional metal cut key, and the power button has replaced the ignition switch. The smart key only needs to be in proximity to the vehicle to allow the system to function.

- With the brake pedal released, the first push of the power button operates the accessory mode, the second push operates the ignition-on mode, and the third push turns the ignition off again.

Ignition Mode Sequence (brake pedal released):

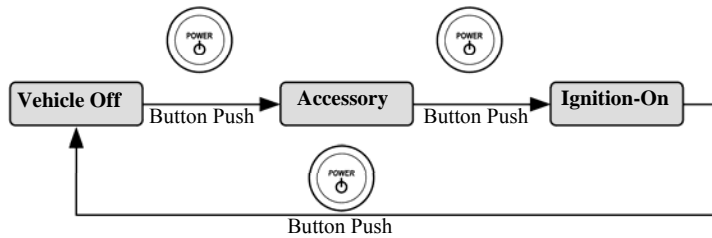

- Starting the vehicle takes priority over all other ignition modes and is accomplished by depressing the brake pedal and pushing the power button once. To verify the vehicle has started, and the **READY** light is illuminated in the instrument cluster.
- If the internal smart key battery is dead, use the following method to start the vehicle.
 1. Touch the Toyota emblem side of the smart key to the power button.
 2. Within the 10 seconds after the buzzer sounds, push the power button with the brake pedal depressed (the **READY** light will illuminate).
- Once the vehicle has started and is on and operational (**READY-ON**), the vehicle is shut off by bringing the vehicle to a complete stop and then depressing the power button once.
- To shut off the vehicle before coming to a stop in an emergency, push and hold down the power button for more than 3 seconds. This procedure may be useful at an accident scene in which the **READY** indicator is on, park (P) cannot be selected, and the drive wheels remain in motion.

Ignition Mode	Multi-information Display (Instrument Cluster)
Off	-
Accessory	POWER ON
Ignition-On	POWER ON
Brake Pedal Depressed	Smart Key Symbol
Vehicle Started (READY-ON)	-
Malfunction	Warning Message

<p>POWER ON & Smart Key Symbol (Multi-information Display)</p>	<p>Ignition Modes (Brake Pedal Released)</p>
<p>Starting Sequence (Brake Pedal Depressed)</p>	<p>Smart Key Recognition (When Smart Key Battery is Dead)</p>

Hybrid Synergy Drive Operation

Once the **READY** indicator is illuminated in the instrument cluster, the vehicle may be driven. However, the petrol engine does not idle like a typical automobile and will start and stop automatically. It is important to recognise and understand the **READY** indicator provided in the instrument cluster. When lit, it informs the driver that the vehicle is on and operational even though the petrol engine may be off and the engine compartment is silent.

Vehicle Operation

- With the PriusC, the petrol engine may stop and start at any time while the **READY** indicator is on.
- Never assume that the vehicle is shut off just because the engine is off. Always look for the **READY** indicator status. The vehicle is shut off when the **READY** indicator is off.
- The vehicle may be powered by:
 1. The electric motor only.
 2. A combination of both the electric motor and the petrol engine.
- The vehicle computer determines how the vehicle operates in order to improve fuel economy and reduce emissions. Two features on the PriusC are EV (Electric Vehicle) mode and ECO (Economy) mode:
 1. EV Mode: When activated, and certain conditions have been met, the vehicle operates with the electric motor powered by the HV battery.
 2. ECO Mode: When activated, this mode helps enhance fuel economy on trips that involve frequent braking and acceleration.

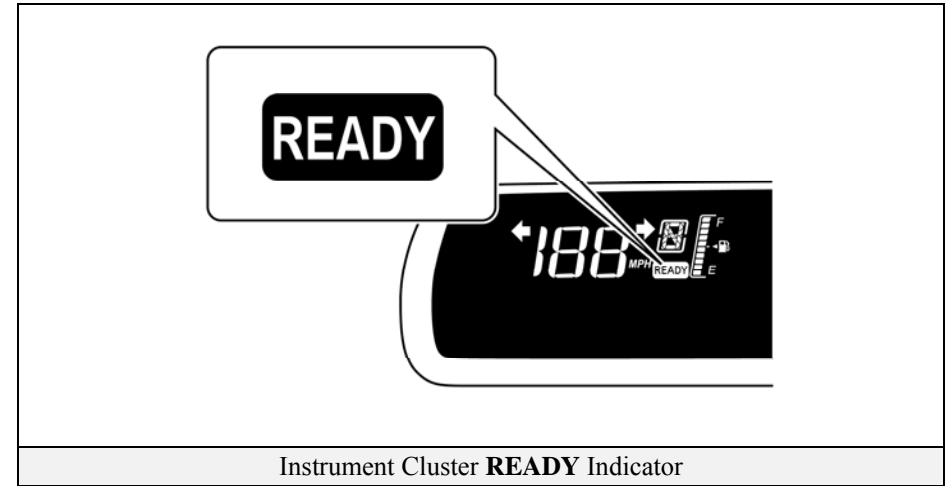

Instrument Cluster **READY** Indicator

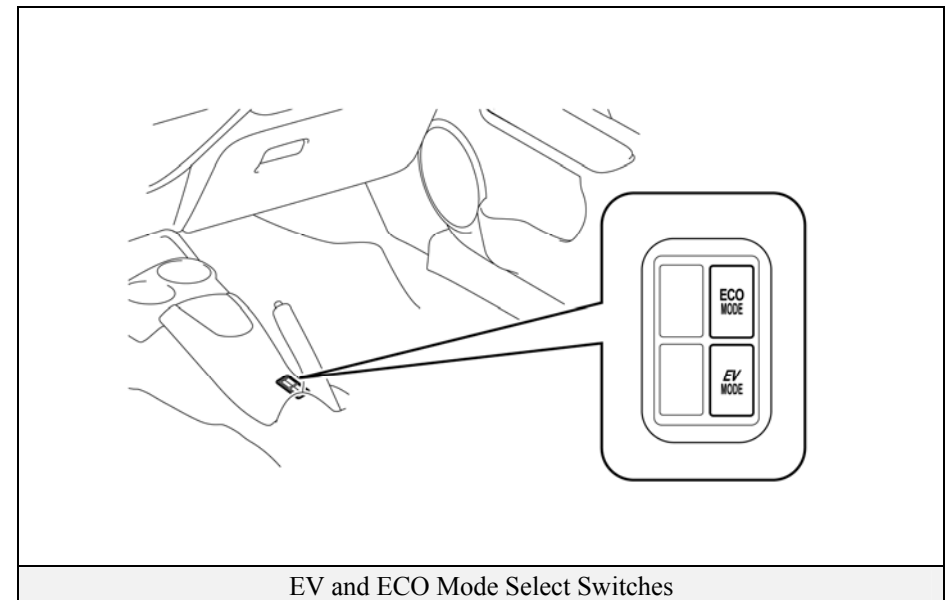

EV and ECO Mode Select Switches

Hybrid Vehicle (HV) Battery Pack

The PriusC features a high voltage Hybrid Vehicle (HV) battery pack that contains sealed Nickel Metal Hydride (NiMH) battery modules.

HV Battery Pack

- The HV battery assembly is enclosed in a metal case and is rigidly mounted under the rear seat. The metal case is isolated from high voltage.
- The HV battery pack consists of 20 low voltage (7.2 Volt) NiMH battery modules connected in series to produce approximately 144 Volts. Each NiMH battery module is non-spillable and in a sealed case.
- The electrolyte used in the NiMH battery module is an alkaline mixture of potassium and sodium hydroxide. The electrolyte is absorbed into the battery cell plates and will not normally leak, even in a collision.

HV Battery Pack	
Battery pack voltage	144 V
Number of NiMH battery modules in pack	20
NiMH battery module voltage	7.2 V
NiMH battery module dimensions	118 x 20 x 276 mm
NiMH module weight	1.04 kg
NiMH battery pack dimensions	387 x 1011 x 225 mm
NiMH battery pack weight	31 kg

Note: Values in inches have been rounded

Components Powered by the HV Battery Pack

- Electric Motor
- Inverter/Converter
- Power Cables
- A/C Compressor
- Electric Generator

HV Battery Pack Recycling

- The HV battery pack is recyclable. Contact the nearest Toyota dealer.

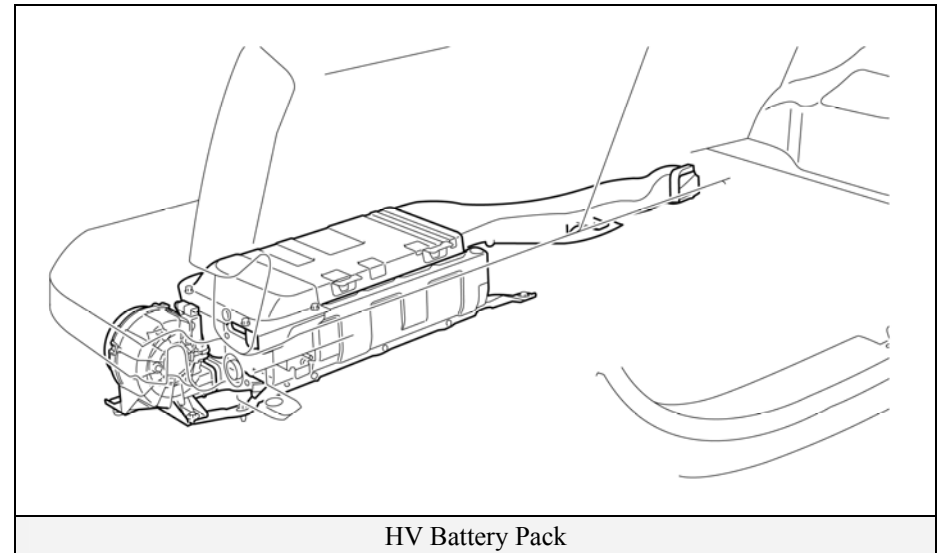

27 Volt System

The PriusC is equipped with a 27 Volt AC assist motor for the Electric Power Steering (EPS) system. The EPS computer generates 27 Volts from the 12 Volt system. The 27 Volt wires are isolated from the metal chassis and routed a short distance from the EPS computer to the EPS assist motor in the steering column.

NOTE:

27 Volts AC has a higher arc potential than 12 Volts DC.

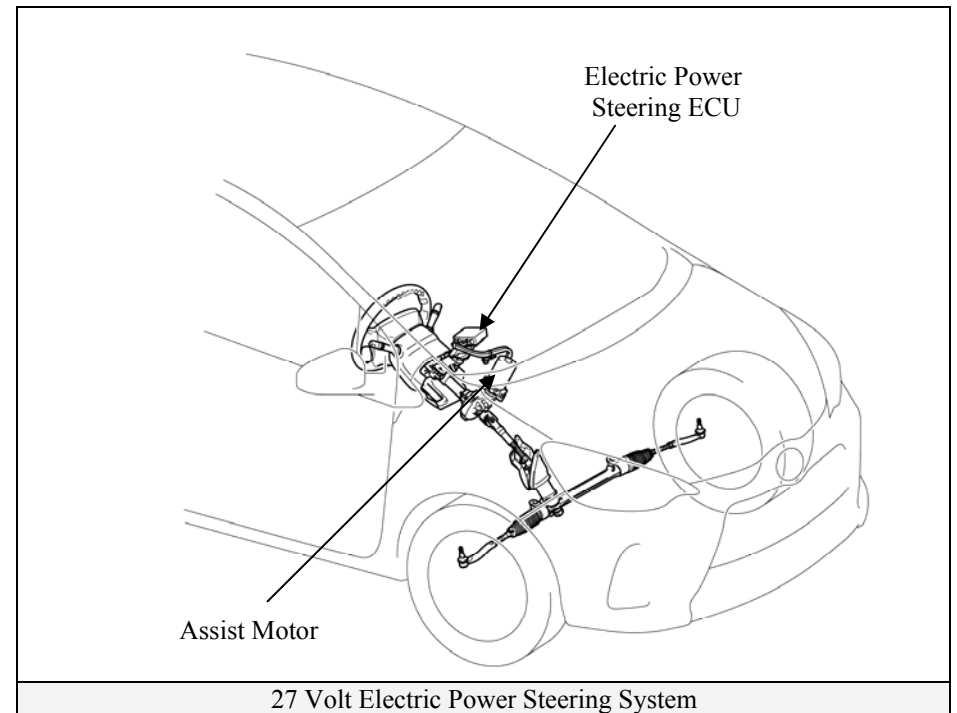

Low Voltage Battery

Auxiliary Battery

- The PriusC contains a sealed lead-acid 12 Volt battery. The 12 Volt auxiliary battery powers the vehicle's electrical system similar to a conventional vehicle. As with conventional vehicles, the negative terminal of the auxiliary battery is grounded to the metal chassis of the vehicle.
- The auxiliary battery is located under the rear seat.

NOTE:

An under hood label shows the location of the HV battery (traction battery) and 12 Volt auxiliary battery.

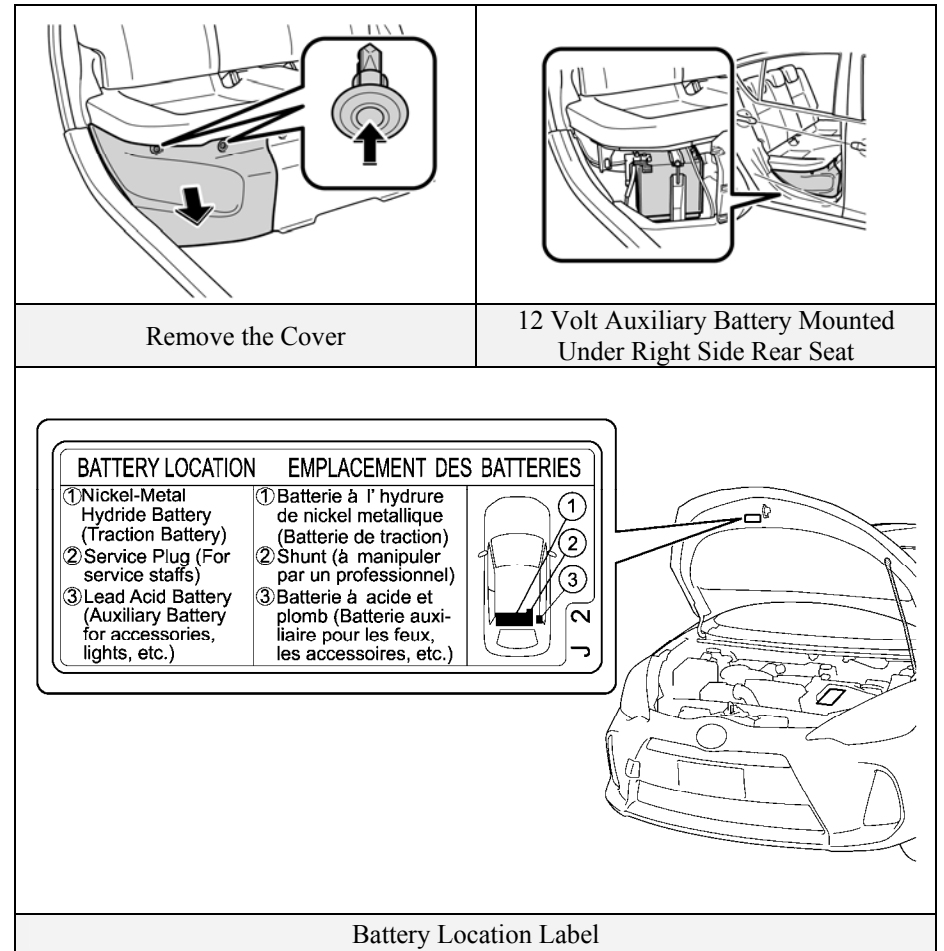

High Voltage Safety

The HV battery pack powers the high voltage electrical system with DC electricity. Positive and negative orange coloured high voltage power cables are routed from the battery pack, under the vehicle floor pan, to the inverter/converter. The inverter/converter contains a circuit that boosts the HV battery voltage from 144 to 520 Volts DC. The inverter/converter creates 3-phase AC to power the motor. Power cables are routed from the inverter/converter to each high voltage motor (electric motor, electric generator, and A/C compressor). The following systems are intended to help keep occupants in the vehicle and emergency responders safe from high voltage electricity:

High Voltage Safety System

- A high voltage fuse ❶ provides short circuit protection in the HV battery pack.
- Positive and negative high voltage power cables ❷ connected to the HV battery pack are controlled by 12 Volt normally open relays ❸. When the vehicle is shut off, the relays stop electrical flow from leaving the HV battery pack.

⚠️ WARNING:

The high voltage system may remain powered for up to 10 minutes after the vehicle is shut off or disabled. To prevent serious injury or death from severe burns or electric shock, avoid touching, cutting, or breaching any orange high voltage power cable or high voltage component.

- Both positive and negative power cables ❷ are insulated from the metal body. High voltage electricity flows through these cables and not through the metal vehicle body. The metal vehicle body is safe to touch because it is insulated from high voltage components.
- A ground fault monitor ❹ continuously monitors for high voltage leakage to the metal chassis while the vehicle is running. If a malfunction is detected, the hybrid vehicle computer ❹ will illuminate the master warning light ⚠️ in the instrument cluster and indicate “Check Hybrid System” on the multi-information display.

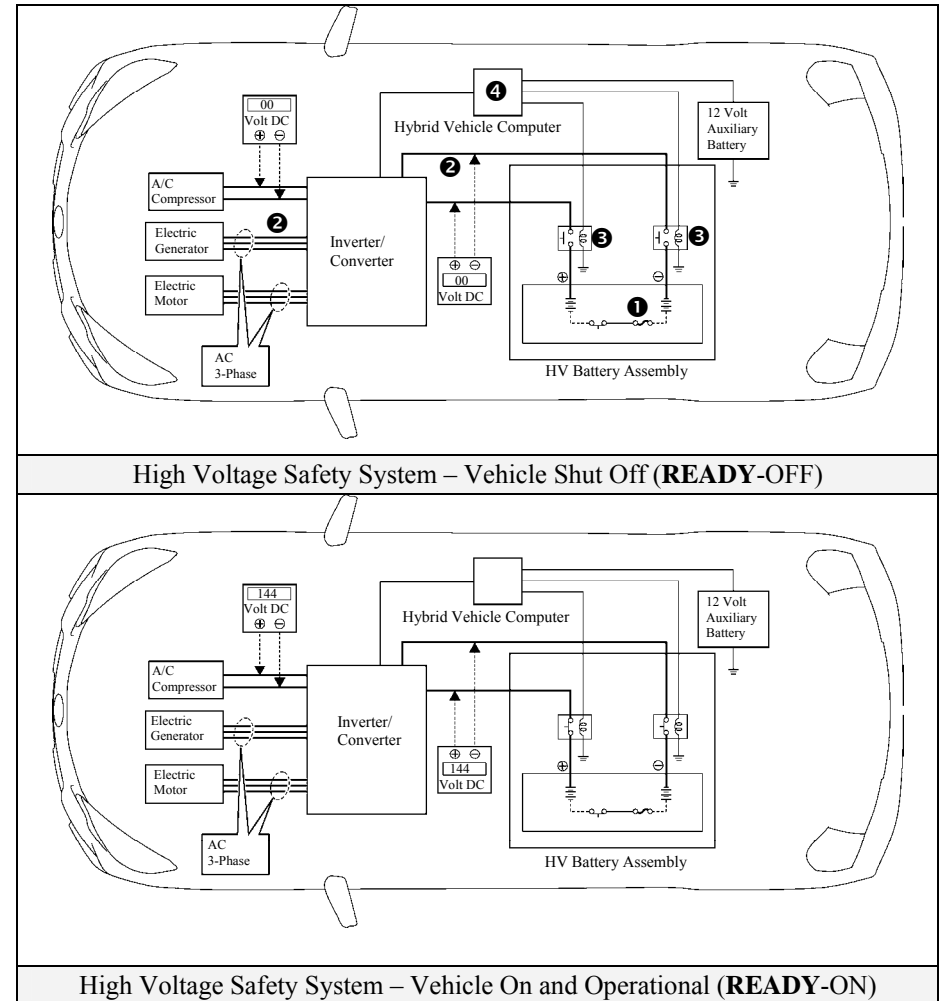

SRS Airbags & Seat Belt Pretensioners

Standard Equipment

- Electronic frontal impact sensors (2) are mounted in the engine compartment ① as illustrated.
- Front seat belt pretensioners are mounted near the base of the B-pillars ②.
- A frontal driver airbag ③ is mounted in the steering wheel hub.
- A frontal passenger airbag ④ is integrated into the dashboard and deploys through the top of the dashboard.
- The SRS computer ⑤, which contains an impact sensor, is mounted on the floor pan underneath the instrument panel.
- Front electronic side impact sensors (2) are mounted near the base of the B-pillars. ⑥
- Rear electronic side impact sensors (2) are mounted near the base of the C-pillars. ⑦
- Front seat side airbags ⑧ are mounted in the front seatbacks.
- Side curtain airbags ⑨ are mounted along the outer edge inside the roof rails.
- A driver knee airbag ⑩ is mounted on the lower portion of the dash.

WARNING:

The SRS may remain powered for up to 90 seconds after the vehicle is shut off or disabled. To prevent serious injury or death from unintentional SRS deployment, avoid breaching the SRS components.

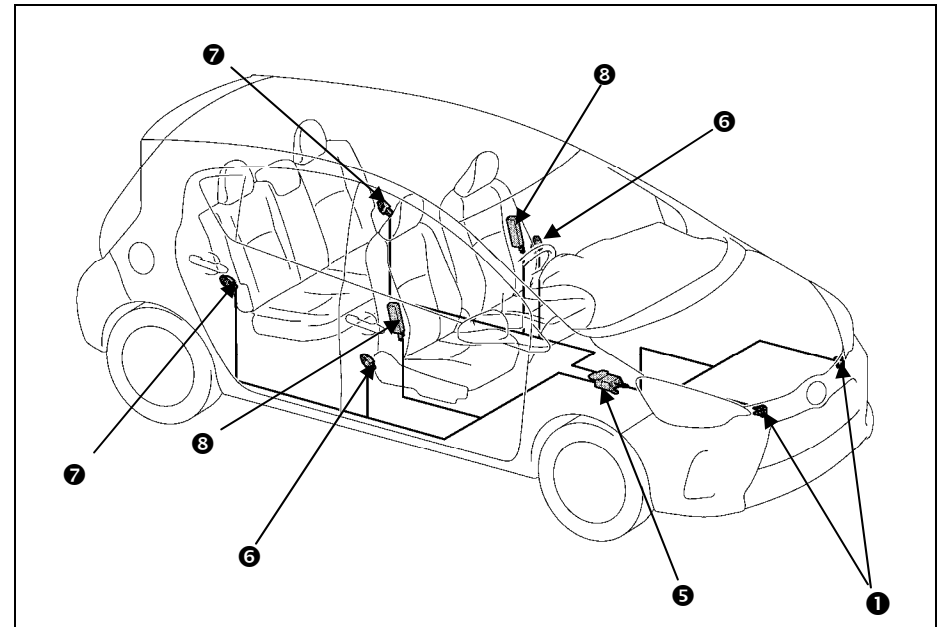

Electronic Impact Sensors and Side Airbags

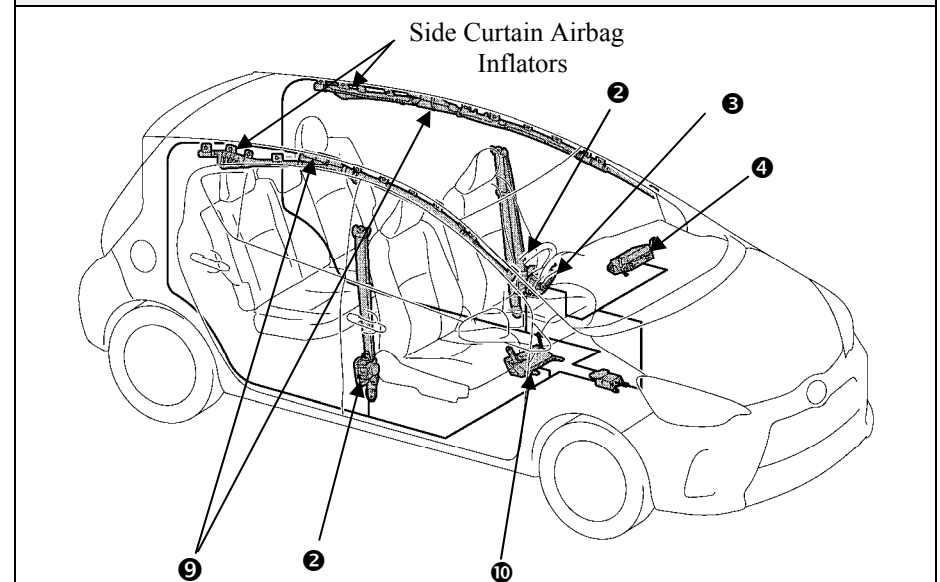

Standard Frontal Airbags, Seat Belt Pretensioners, Driver Knee Airbag, Side Curtain Airbags

SRS Airbags & Seat Belt Pretensioners (Continued)

NOTE:

The front seatback mounted side airbags and the side curtain airbags may deploy independently of each other.

The knee airbag is designed to deploy simultaneously with the frontal airbag.

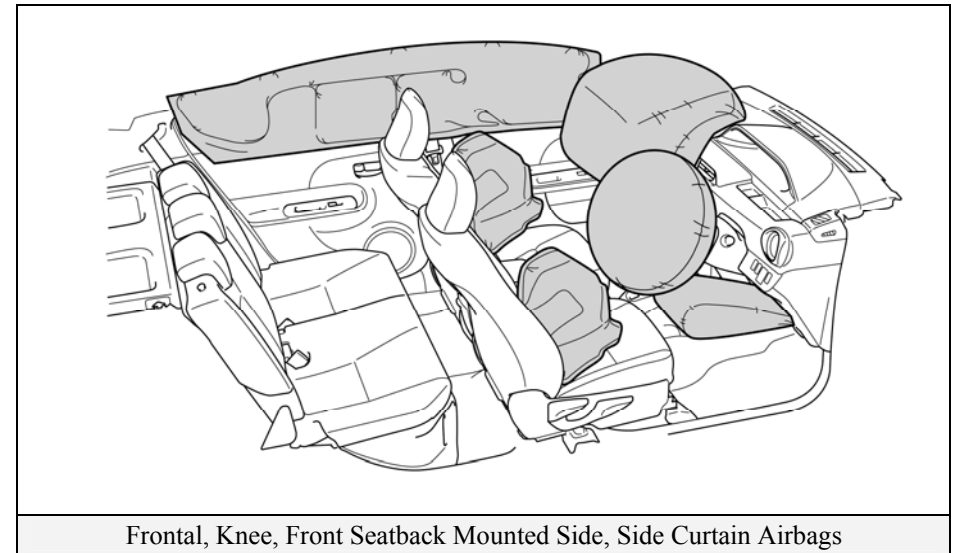
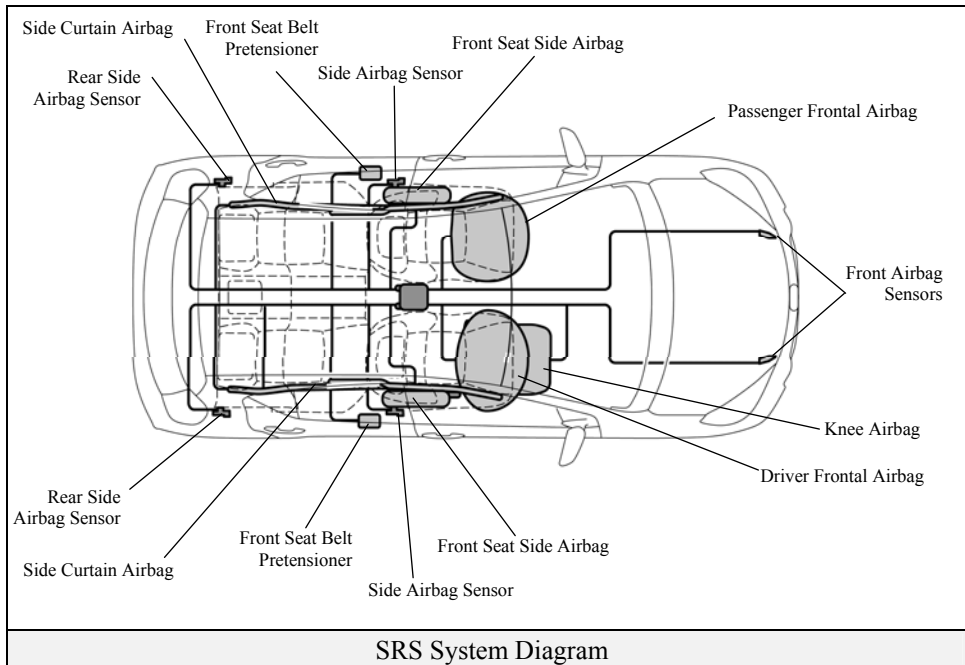

Emergency Response

On arrival, emergency responders should follow their standard operating procedures for vehicle incidents. Emergencies involving the PriusC may be handled like other automobiles except as noted in these guidelines for Extrication, Fire, Overhaul, Recovery, Spills, First Aid, and Submersion.

⚠ WARNING:

- *Never assume the PriusC is shut off simply because it is silent.*
- *Always observe the instrument cluster for the **READY** indicator status to verify whether the vehicle is on or shut off. The vehicle is shut off when the **READY** indicator is off.*
- *Failure to shut off and disable the vehicle before emergency response procedures are performed may result in serious injury or death from the unintentional deployment of the SRS or severe burns and electric shock from the high voltage electrical system.*

Extrication

- **Immobilise Vehicle**
Chock wheels and set the parking brake.
Move the shift lever to the **Park** position.
- **Disable Vehicle**
Performing either of the following two procedures will shut the vehicle off and disable the HV battery pack, SRS, and petrol fuel pump.

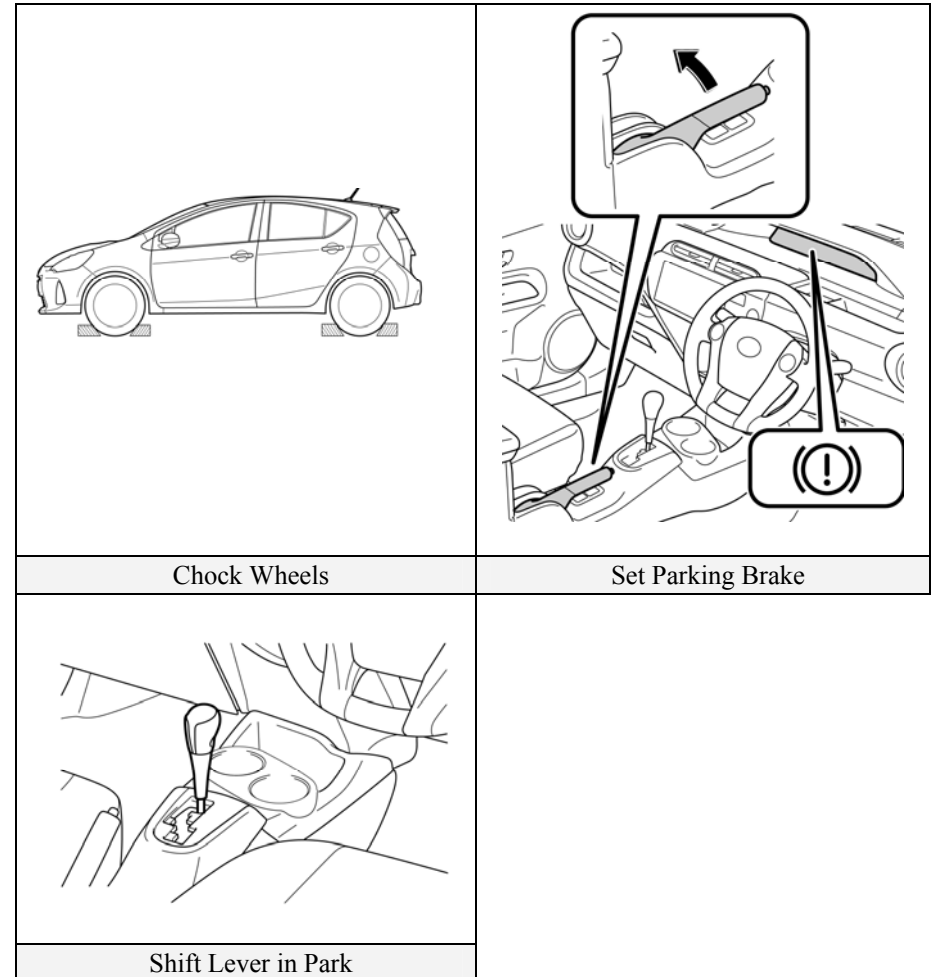

Emergency Response (Continued)

Extrication (Continued)

Procedure #1

1. Confirm the status of the **READY** indicator in the instrument cluster.
2. If the **READY** indicator is illuminated, the vehicle is on and operational. Shut off the vehicle by pushing the power button once.
3. The vehicle is already shut off if the instrument cluster lights and the **READY** indicator are not illuminated. Do **not** push the power button because the vehicle may start.
4. If the smart key is easily accessible, keep it at least 16 feet (5 meters) away from the vehicle and disconnect the 12 Volt auxiliary battery under the right side rear seat and disconnect the 12 Volt auxiliary battery under the right side rear seat.
5. If the smart key cannot be found, disconnect the 12 Volt auxiliary battery under the right side rear seat to prevent accidental restarting of the vehicle.

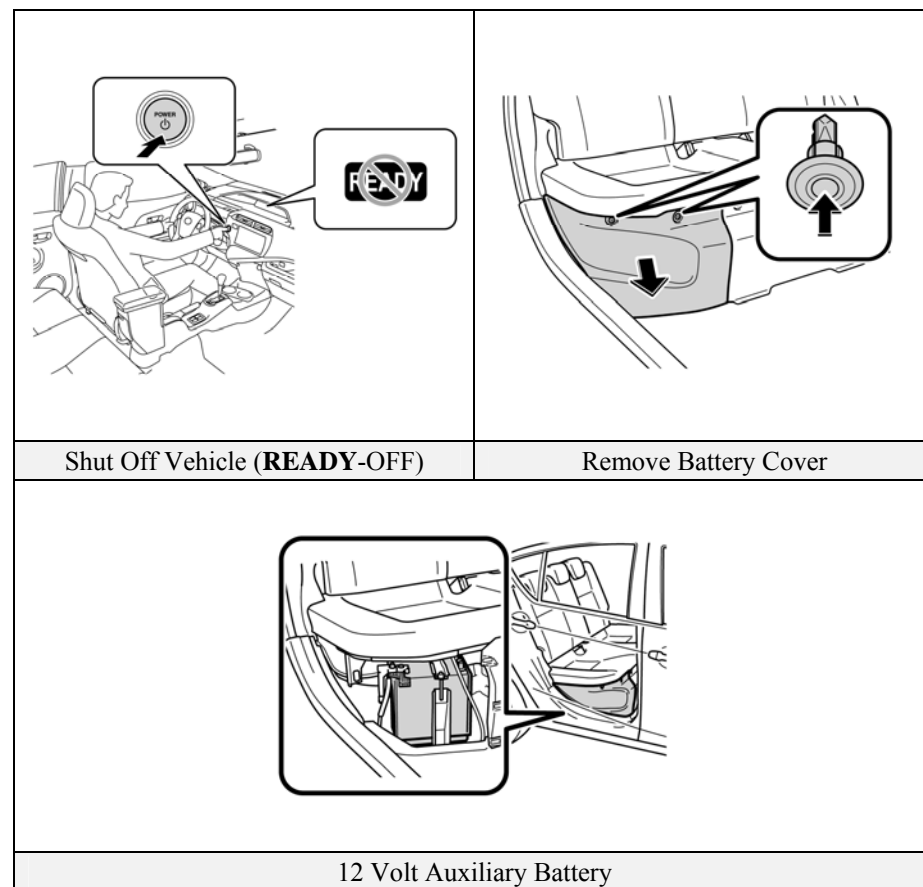

Emergency Response (Continued)

Extrication (Continued)

Procedure #2 (Alternate if power button is inaccessible)

1. Open the hood.
2. Remove the fuse box cover.
3. Remove the **IG2** fuse (30A green coloured) in the engine compartment fuse box (refer to illustration). If the correct fuse cannot be recognised, pull all fuses in the fuse box.
4. Disconnect the 12 Volt auxiliary battery under the right side rear seat.

NOTE:

Before disconnecting the 12 Volt auxiliary battery, if necessary, lower the windows, unlock the doors and open the back door as required. Once the 12 Volt auxiliary battery is disconnected, power controls will not operate.

⚠ WARNING:

- *The high voltage system may remain powered for up to 10 minutes after the vehicle is shut off or disabled. To prevent serious injury or death from severe burns or electric shock, avoid touching, cutting, or breaching any orange high voltage power cable or high voltage component.*
- *The SRS may remain powered for up to 90 seconds after the vehicle is shut off or disabled. To prevent serious injury or death from unintentional SRS deployment, avoid breaching the SRS components.*
- *If none of the disabling procedures can be performed, proceed with caution as there is no assurance that the high voltage electrical system, SRS, or fuel pump are disabled.*

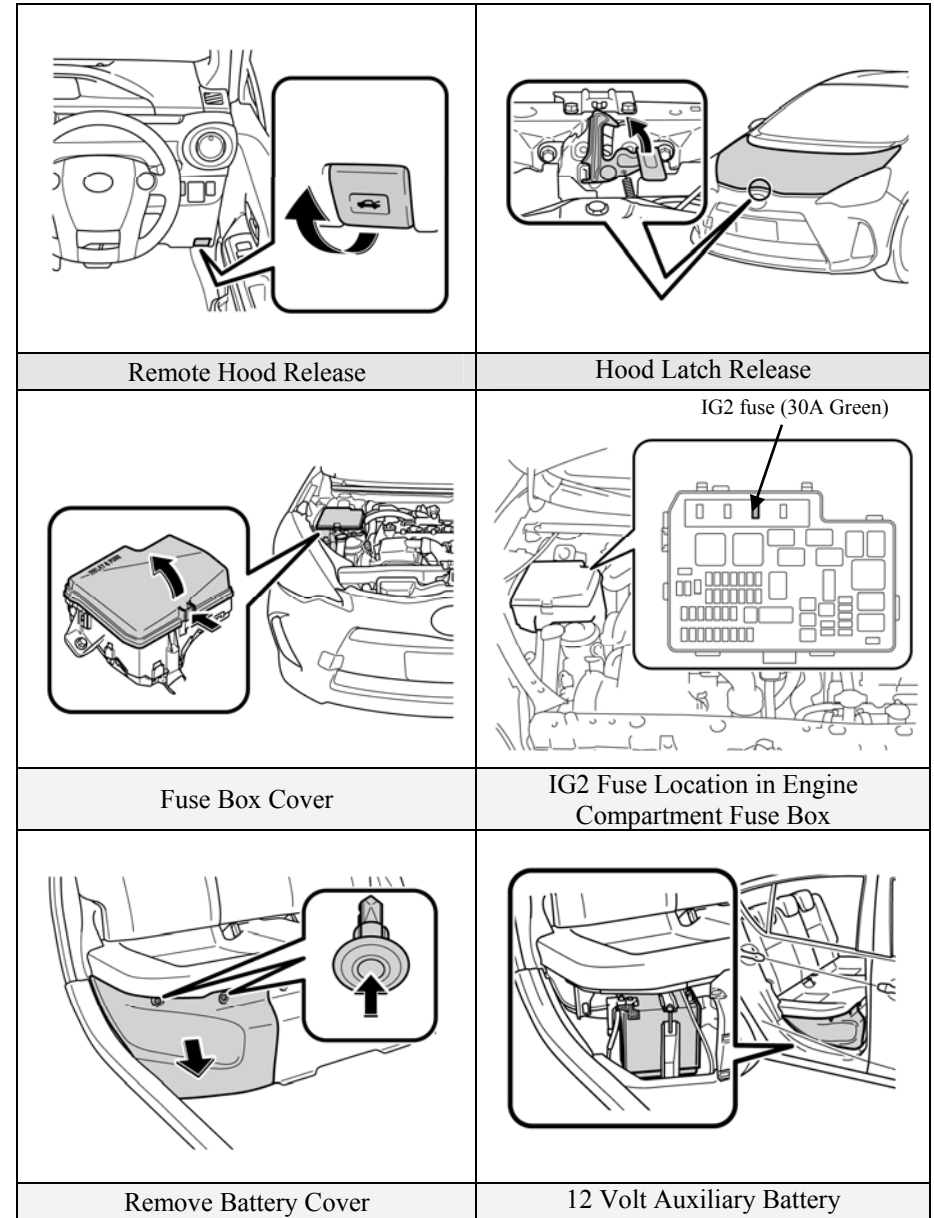

Emergency Response (Continued)

Extrication (Continued)

- Stabilise Vehicle

Crib at (4) points directly under the front and rear pillars.
Do not place cribbing under the high voltage power cables, exhaust system, or fuel system.

- Access Patients

Glass Removal

Use normal glass removal procedures as required.

SRS Awareness

Responders need to be cautious when working in close proximity to undeployed airbags and seat belt pretensioners.

Door Removal/Displacement

Doors can be removed by conventional rescue tools such as hand, electric, and hydraulic tools. In certain situations, it may be easier to pry back the vehicle body to expose and unbolt the hinges.

NOTE:

To prevent accidental airbag deployment when performing front door removal/displacement, ensure the vehicle is shut off and the 12 Volt auxiliary battery is disconnected.

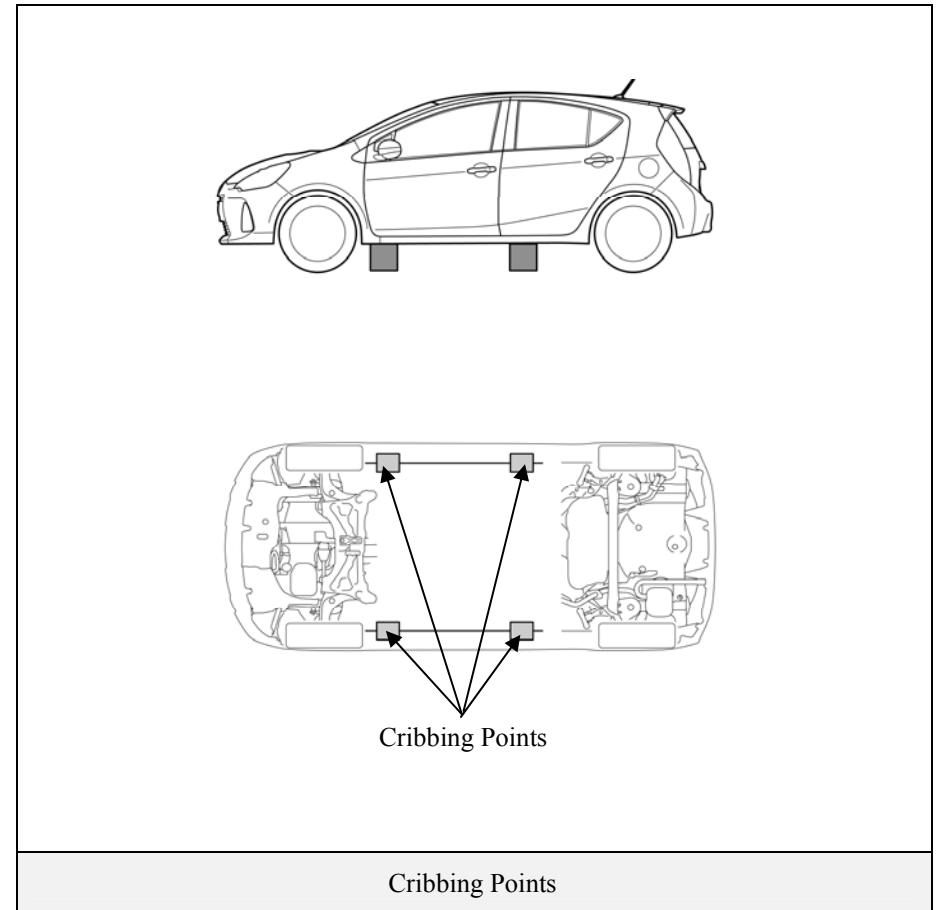

Emergency Response (Continued)

Extrication (Continued)

Roof Removal

The PriusC is equipped with side curtain airbags. When undeployed, total roof removal is not recommended. Patient access through the roof can be performed by cutting the roof center section inboard of the roof rails as illustrated. This would avoid breaching the side curtain airbags, inflators, and wiring harness.

NOTE:

The side curtain airbags may be identified as illustrated on this page (additional component details on page 15).

Dash Displacement

The PriusC is equipped with side curtain airbags. When undeployed, total roof removal is not recommended to avoid breaching the side curtain airbags, inflators, and wiring harness. As an alternative, dash displacement may be performed by using a Modified Dash Roll.

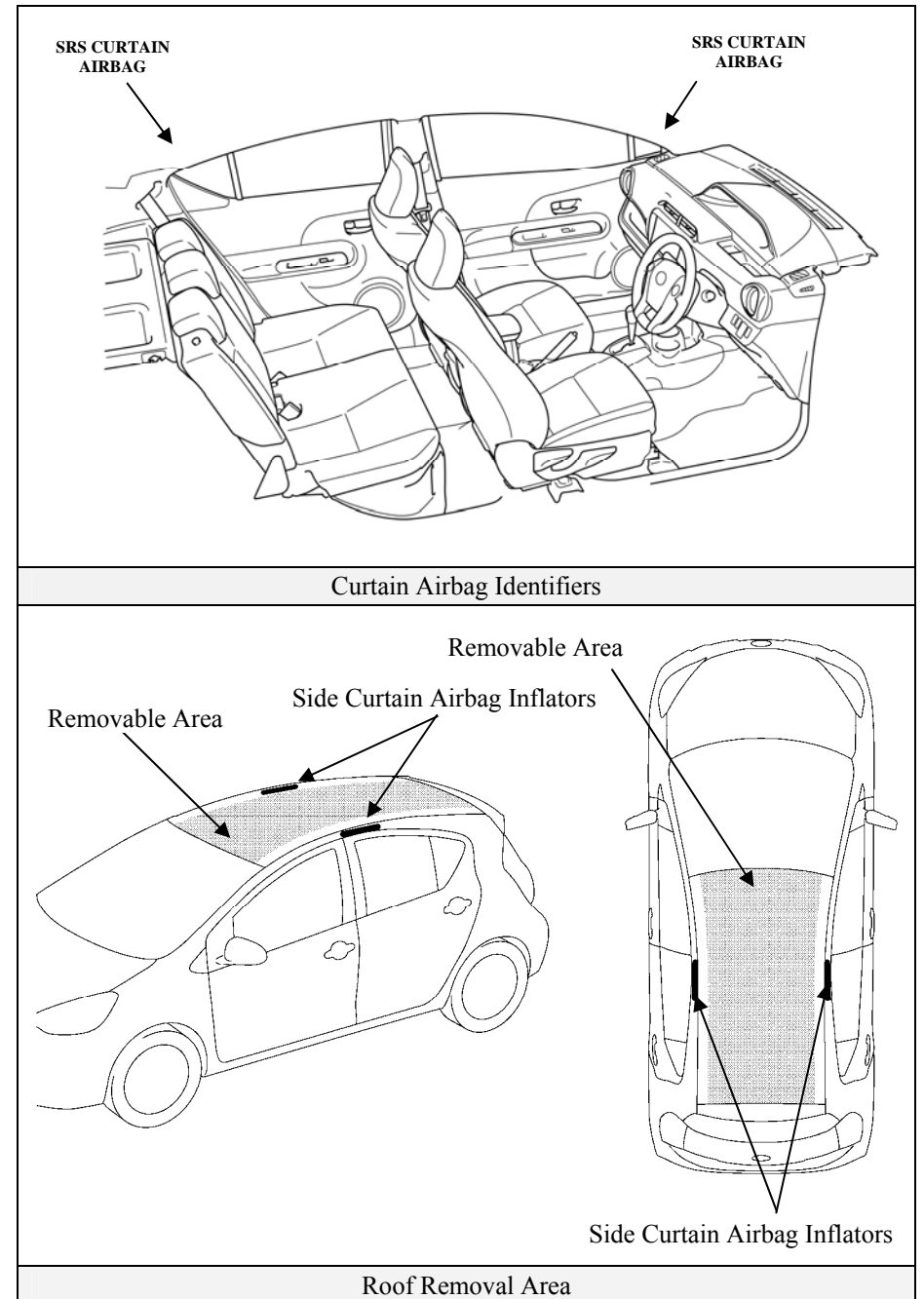

Emergency Response (Continued)

Extrication (Continued)

Rescue Lift Air Bags

Do not place cribbing or rescue lift air bags under the high voltage power cables, exhaust system, or fuel system.

Repositioning Steering Wheel and Front Seat

Telescopic steering wheel and seat controls are shown in the illustrations.

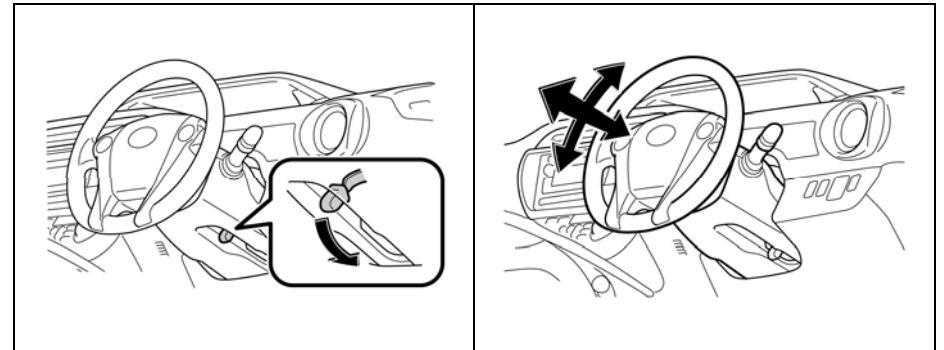

Tilt and Telescoping Control

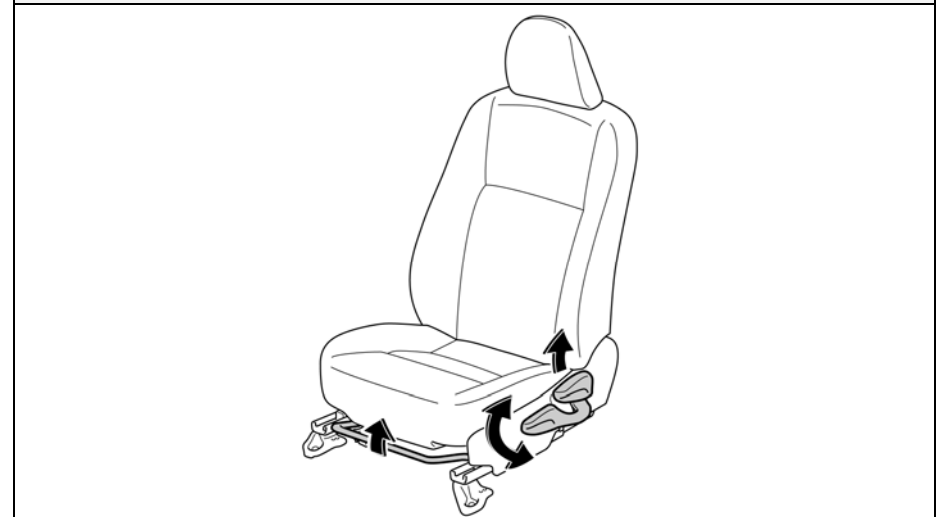

Front Seat Controls

Emergency Response (Continued)

Fire

- Extinguishing Agent
Water has been proven to be a suitable extinguishing agent.
- Initial Fire Attack
Perform a fast, aggressive fire attack.
Divert the runoff from entering watershed areas.
Attack teams may not be able to identify a PriusC until the fire has been knocked down and overhaul operations have commenced.
- Fire in the HV Battery Pack
Should a fire occur in the NiMH HV battery pack, attack crews should utilise a water stream or fog pattern to extinguish any fire within the vehicle *except* for the HV battery pack.

WARNING:

- *The NiMH battery electrolyte is a caustic alkaline (pH 13.5) that is damaging to human tissues. To avoid injury by coming in contact with the electrolyte, wear proper personal protective equipment.*
- *The battery modules are contained within a metal case and accessibility is limited.*
- *To avoid serious injury or death from severe burns or electric shock, **never** breach or remove the high voltage battery pack cover under any circumstance including fire.*

When allowed to burn themselves out, the PriusC NiMH battery modules burn rapidly and can quickly be reduced to ashes except for the metal.

Offensive Fire Attack

Normally, flooding an NiMH HV battery pack with copious amounts of water at a safe distance will effectively control the HV battery pack fire by cooling the adjacent NiMH battery modules to a point below their ignition temperature. The remaining modules on fire, if not extinguished by the water, will burn themselves out.

However, flooding the PriusC HV battery pack is *not* recommended due to the battery case design and location preventing the responder from properly applying water through the available vent openings safely. Therefore, it is recommended that the incident commander allow the PriusC HV battery pack to burn itself out.

Defensive Fire Attack

If the decision has been made to fight the fire using a defensive attack, the fire attack crew should pull back a safe distance and allow the NiMH battery modules to burn themselves out. During this defensive operation, fire crews may utilise a water stream or fog pattern to protect exposures or to control the path of smoke.

Emergency Response (Continued)

Overhaul

During overhaul, immobilise and disable the vehicle if not already done. Refer to illustrations on page 17, 18 and 19. The HV battery cover should *never* be breached or removed under any circumstances including fire. Doing so may result in severe electrical burns, shock, or electrocution.

- Immobilise Vehicle
 - Chock wheels and set the parking brake.
 - Move the shift lever to the Park position.
- Disable Vehicle
 - Performing either of the following two procedures will shut the vehicle off and disable the HV battery pack, SRS, and petrol fuel pump.

Procedure #1

1. Confirm the status of the **READY** indicator in the instrument cluster.
2. If the **READY** indicator is illuminated, the vehicle is on and operational. Shut off the vehicle by pushing the power button once.
3. The vehicle is already shut off if the instrument cluster lights and the **READY** indicator are not illuminated. Do **not** push the power button because the vehicle may start.
4. If the smart key is easily accessible, keep it at least 16 feet (5 meters) away from the vehicle and disconnect the 12 Volt auxiliary battery under the right side rear seat and disconnect the 12 Volt auxiliary battery under the right side rear seat.
5. If the smart key cannot be found, disconnect the 12 Volt auxiliary battery under the right side rear seat to prevent accidental restarting of the vehicle.

Procedure #2 (Alternate if power button is inaccessible)

5. Open the hood.
6. Remove the fuse box cover.
7. Remove the **IG2** fuse (30A green coloured) in the engine compartment fuse box (refer to illustration). If the correct fuse cannot be recognised, pull all fuses in the fuse box.
8. Disconnect the 12 Volt auxiliary battery under the right side rear seat.

NOTE:

Before disconnecting the 12 Volt auxiliary battery, if necessary, lower the windows, unlock the doors and open the back door as required. Once the 12 Volt auxiliary battery is disconnected, power controls will not operate.

WARNING:

- *The high voltage system may remain powered for up to 10 minutes after the vehicle is shut off or disabled. To prevent serious injury or death from severe burns or electric shock, avoid touching, cutting, or breaching any orange high voltage power cable or high voltage component.*
- *The SRS may remain powered for up to 90 seconds after the vehicle is shut off or disabled. To prevent serious injury or death from unintentional SRS deployment, avoid breaching the SRS components.*
- *If none of the disabling procedures can be performed, proceed with caution as there is no assurance that the high voltage electrical system, SRS, or fuel pump are disabled.*

Recovering/Recycling of NiMH HV Battery Pack

Clean up of the HV battery pack can be accomplished by the vehicle recovery crew without further concern of runoff or spillage. For information regarding recycling of the HV battery pack, contact the nearest Toyota dealer.

Emergency Response (Continued)

Spills

The PriusC contains the same common automotive fluids used in other non-hybrid Toyota vehicles, with the exception of the NiMH electrolyte used in the HV battery pack. The NiMH battery electrolyte is a caustic alkaline (pH 13.5) that is damaging to human tissues. The electrolyte, however, is absorbed in the cell plates and will not normally spill or leak out even if a battery module is cracked. A catastrophic crash that would breach both the metal battery pack case and a battery module would be a rare occurrence.

Similar to the use of baking soda to neutralise a lead-acid battery electrolyte spill, a dilute boric acid solution or vinegar can be used to neutralise a NiMH battery electrolyte spill.

NOTE:

Electrolyte leakage from the HV battery pack is unlikely due to its construction and the amount of available electrolyte contained within the NiMH modules. Any spillage would not warrant a declaration as a hazardous material incident. Responders should follow the recommendations as outlined in this emergency response guide.

In an emergency, the NiMH battery (part number G9280-5230) manufacturer's Material Safety Data Sheet (MSDS).

- Handle NiMH electrolyte spills using the following Personal Protective Equipment (PPE):
 - Splash shield or safety goggles. Fold down helmet shields are not acceptable for acid or electrolyte spills.
 - Rubber, latex or nitrile gloves.
 - Apron suitable for alkaline.
 - Rubber boots.
- Neutralise NiMH Electrolyte
 - Use a boric acid solution or vinegar.
 - Boric acid solution - 800 grams boric acid to 20 litres water or 5.5 ounces boric acid to 1 gallon of water.

First Aid

Emergency responders may not be familiar with a NiMH electrolyte exposure when rendering aid to a patient. Exposure to the electrolyte is unlikely except in a catastrophic crash or through improper handling. Utilise the following guidelines in the event of exposure.

WARNING:

The NiMH battery electrolyte is a caustic alkaline (pH 13.5) that is damaging to human tissues. To avoid injury by coming in contact with the electrolyte, wear proper personal protective equipment.

- Wear Personal Protective Equipment (PPE)
 - Splash shield or safety goggles. Fold down helmet shields are not acceptable for acid or electrolyte spills.
 - Rubber, latex or nitrile gloves.
 - Apron suitable for alkaline.
 - Rubber boots.
- Absorption
 - Perform gross decontamination by removing affected clothing and properly disposing of the garments.
 - Rinse the affected areas with water for 20 minutes.
 - Transport patients to the nearest emergency medical care facility.
- Inhalation in Non-Fire Situations
 - No toxic gases are emitted under normal conditions.
- Inhalation in Fire Situations
 - Toxic gases are given off as by-products of combustion. All responders in the Hot Zone should wear the proper PPE for fire fighting including SCBA.
 - Move a patient from the hazardous environment to a safe area and administer oxygen.
 - Transport patients to the nearest emergency medical care facility.

Emergency Response (Continued)

First Aid (Continued)

- Ingestion
 - Do not induce vomiting.
 - Allow the patient to drink large quantities of water to dilute the electrolyte (never give water to an unconscious person).
 - If vomiting occurs spontaneously, keep the patient's head lowered and forward to reduce the risk of aspiration.
 - Transport patients to the nearest emergency medical care facility.

Submersion

A submerged hybrid vehicle does not have high voltage potential on the metal vehicle body, and is safe to touch.

Access Patients

Responders can access the patient and perform normal extrication procedures. High voltage orange colour coded power cables and high voltage components should never be touched, cut, or breached.

Vehicle Recovery

If a hybrid vehicle is fully or partially submerged in water, emergency responders may not be able to determine if the vehicle has been automatically disabled. The PriusC may be handled by following these recommendations:

1. Remove the vehicle from the water.
2. Drain the water from the vehicle if possible.
3. Follow the immobilising and disabling procedures on page 17, 18 and 19.

Roadside Assistance

Roadside assistance for the Toyota PriusC may be handled like conventional Toyota vehicles except as noted in the following pages.

Shift Lever

Similar to many Toyota vehicles, the PriusC uses a gated shift lever as shown in the illustration. However, the PriusC shift lever includes a **B** position, allowing enhanced engine braking when driving down a steep grade.

Towing

The PriusC is a front wheel drive vehicle and it **must** be towed with the front wheels off the ground. Failure to do so may cause serious damage to Hybrid Synergy Drive components.

- A flat bed trailer is the preferred method of towing.
- With the brake pedal released, press the power switch to turn the ignition-on. Then, move the shift lever from P Position to N position with the brake pedal depressed.
- If the shift lever cannot be moved out of **P**ark, a shift lock release button is provided under the cover near the shift lever as shown in the illustration.
- If a tow truck is not available, in an emergency the vehicle may be moved using a cable or chain secured to the emergency towing eyelet or rear tow hook for short distances at low speeds (below 18 mph (30km/h)). The eyelet is located with the tools in the cargo area of the vehicle, refer to the illustration on page 28.

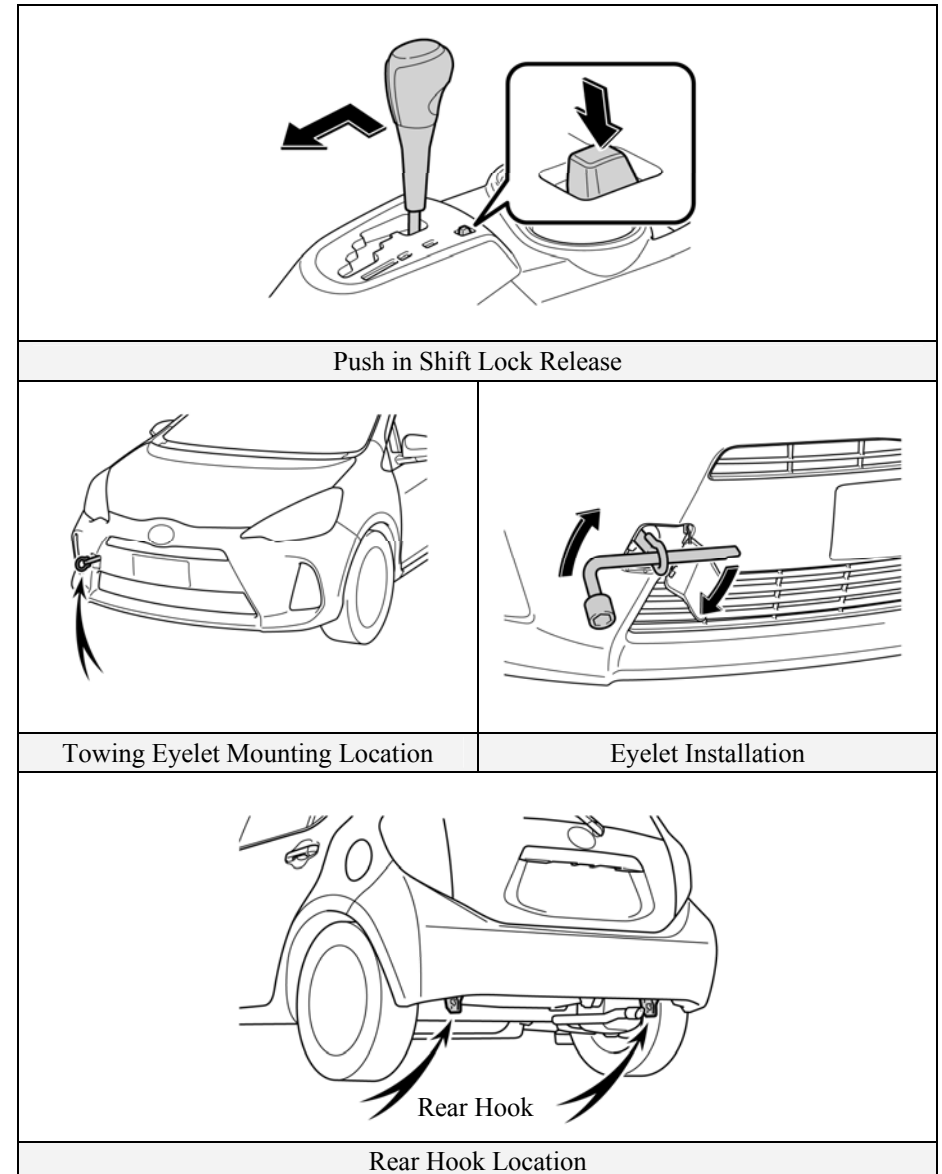

Roadside Assistance (Continued)

Electric Back Door Opener

The PriusC is equipped with an electric back door opener. In the event of 12 Volt power loss, the back door cannot be opened from the outside of the vehicle.

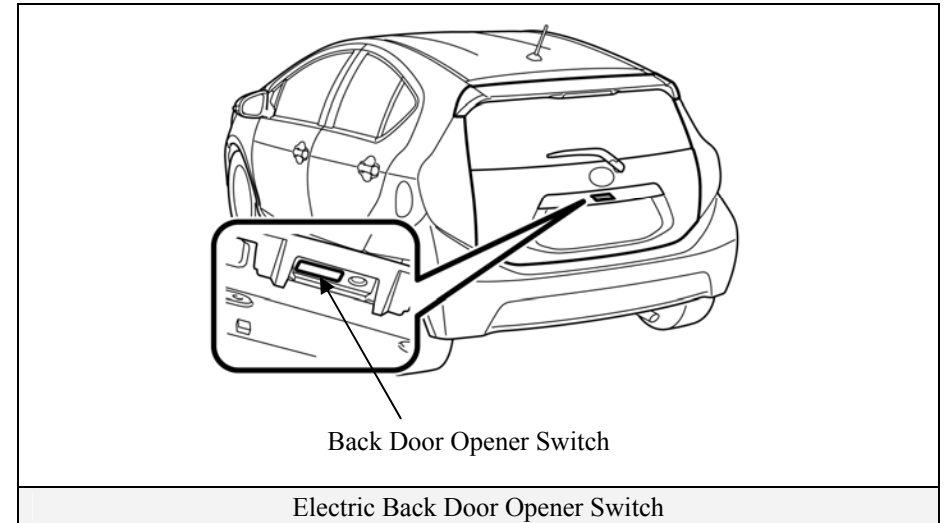

Spare Tire

The jack, tools, towing eyelet and spare tire are provided as shown.

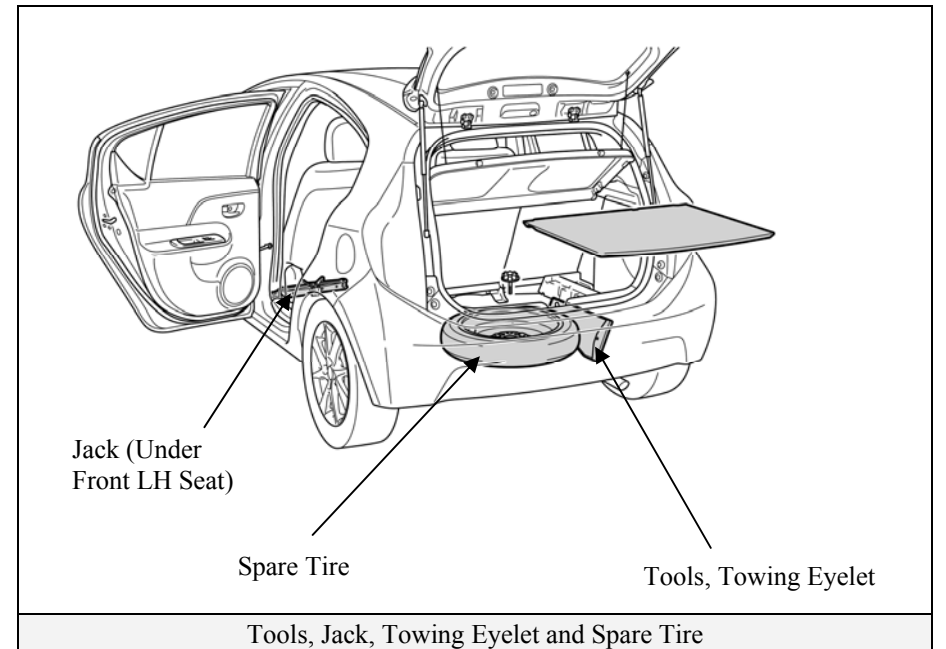

Roadside Assistance (Continued)

Jump Starting

The 12 Volt auxiliary battery may be jump started if the vehicle does not start and the instrument cluster gauges are dim or off after depressing the brake pedal and pushing the power button.

The 12 Volt auxiliary battery is located under the right side rear seat.

- Open the right side rear door and remove the battery cover.
- Connect the positive jumper cable to the positive terminal.
- Connect the negative jumper cable to a negative terminal.
- Place the smart key in proximity to the interior of the vehicle, depress the brake pedal, and push the power button.

NOTE:

If the vehicle does not recognise the smart key after connecting the booster battery to the vehicle, open and close the driver door when the vehicle is shut off.

If the smart key internal battery is dead, touch the Toyota emblem side of the smart key to the power button during the start sequence. Refer to the instructions and illustrations on page 9 for more details.

- The high voltage HV battery pack cannot be jump started.

Immobiliser

The PriusC is equipped with an immobiliser system.

- The vehicle can be started only with a registered smart key.

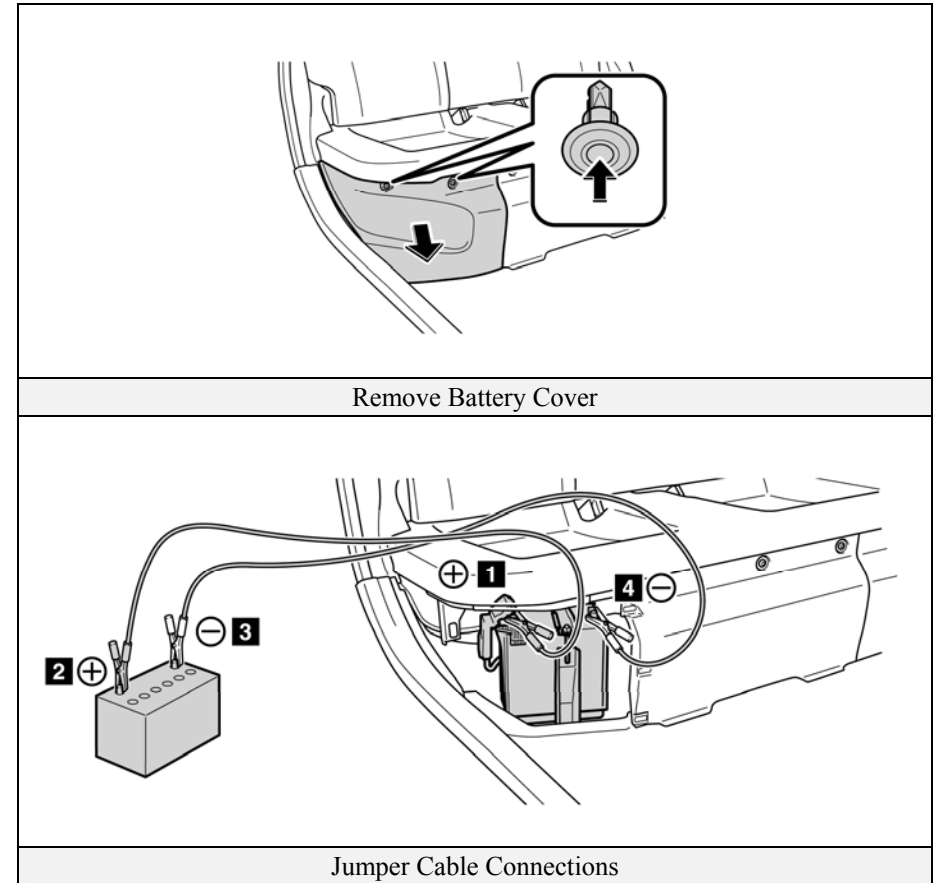

MATERIAL SAFETY DATA SHEET

Nickel/Metal Hydride Battery

(EV-MPGR5R02)

SECTION I - Chemical Product & Company

Manufacturer's Name Panasonic EV Energy Co., Ltd.	Manufacturer's Emergency Telephone Number (81)-53-577-3112. Munehisa Ikoma
Manufacturer's Mailing Address 555 Sakai juku, Kosai, Shizuoka 431-0452 JAPAN	Data Prepared Sep. 19, 2003
	Signature of Preparer (Optional)

SECTION II - Hazardous Ingredients/Identity Information

Hazardous Components (Specific Chemical Identity: Common Name (s))	OSHA PEL ACGIH TLV	Other Limits Recommended	Formulation (
Ni (OH) ₂		0~16%	W
NiOOH		1~17%	W
MmNiCoMnAl		2~21%	W
(MmNiCoMnAl) Hx		3~22%	W
KOH and NaOH and LiOH		14%	W

Other Material:

Battery Case: Plastics (PPE/PP/HSBBC/HSIBC Blend)

PPE: Poly Phenylene Ether, PP: Polypropylene

HSBBC: Hydrogenated Styrene Butadiene Block Copolymer

HSIBC: Hydrogenated Styrene Isoprene Block Copolymer

Separator: Polypropylene-Polyolefine mixed Sheet

SECTION III - Physical/Chemical Characteristics

	Specific Gravity (H ₂ O=1)	1.9
Vapor Pressure (mm Hg)	N/A	Melting Point N/A
Vapor Density (Air=1)	N/A	Evaporation Rate (Butyl Acetate =1) N/A
Solubility in Water (v/v)	N/A	

Appearance and Odour

Note:

- Nickel/Metal hydride battery is solid and sealed by the plastic case. It will not generate any gas in the static condition. In the atmosphere, and in the water, it retains the solid condition.
- In the non-static condition, it may generate oxygen (O₂) when overcharged status and hydrogen (H₂) when overdischarged. Via the safety vent inside the Nickel/Metal hydride battery, these gases may vent out of the case to the atmosphere. Spe of gas generation and volume of gas generation depend upon the charging or discharging condition.

SECTION IV – Fire and Explosion Hazard Date

Flash Point (Method Used)	N/A	Flammable Limits	LEL	UEL
---------------------------	-----	------------------	-----	-----

Note:

- No flash or explosion in the normal situation.
- Flash may be possible in the following cases:
 - Sparking in the case of the short-circuit.
 - Intentionally discharging the cell and/or the module battery with extremely high current.
- Explosion may be possible in the following case:

The Cell itself will not explode if abused because of its safety vent mechanism. However, if the cell is housed in a seal vessel, the cell may explode with an ignition source because of the combination of oxygen (O₂) and hydrogen (H₂) gases generated by the cell.

- Unusual fire and explosion hazards.

Extinguishing media	• CO ₂	• Sand	• Large amounts of water
---------------------	-------------------	--------	--------------------------

Special Fire-fighting Procedures	N/A
----------------------------------	-----

Unusual fire and explosion hazards

- In abnormal usage, there is the possibility of explosion.
- The abnormal usage conditions:
 - Cell was overcharged and overdischarged.
 - Cell was higher than 100°C.
 - Cell is discharged and charged in a sealed vessel with an ignition source.

SECTION V – Reactivity Data

Stability	Unstable		Conditions to Avoid
Stable	Stable	○	

Incompatibility (Materials to Avoid)	N/A
--------------------------------------	-----

Hazardous Decomposition or By-products

- Disassembling the module battery
 - Disassembling the single cell
- • Danger of short-circuiting.
 - • Danger of short-circuiting.
 - Alkaline liquid out.
 - Alkaline liquid to the skin.

Hazardous	May Occur		Conditions to Avoid
Polymerisation	Will Not Occur	○	

SECTION VI – Health Hazard Data

Route (s) Entry:	Inhalation?	Skin?	Ingestion?
• Inhalation:	Any poisonous gas will not be generated. Inhalation of the gas is not harmful.		
• Skin:	In the normal situation, damage to skin will not occur. However, in the abused situation, the electrolyte (alkaline liquid) may leak out of the case which may damage the skin if touched.		
• Ingestion:	No ingestion.		

Health Hazards (Acute and Chronic)

Will not give any hazards in the long run. However, leaked liquid may damage the skin if touched.

Carcinogenicity:	TNP?	IARC Monographs?	OSHA Regulated?
No Carcinogen			

Signs and Symptoms of Exposure

–

Medical Conditions Generally Aggravated by Exposure

–

Emergency and First Aid Procedures

(A) In case the battery case is cracked and broken:

Alkaline electrolyte flows out. If your skin and eye contact it, it causes very serious sore.

Element of alkaline electrolyte : KOH, NaOH, LiOH(PH₁₄)

(B) In case the battery is burned:

A mixed steam is generated. If you inhale it a lot, it causes a stimulation of the mucous membrane, dizziness or vomit.

Main element of a mixed steam:

Carbon monoxide(CO), Carbon dioxide(CO₂), Sulfur oxide(SO_x) 1,3-Butadiene(C₄H₆), Benzene(C₆H₆), Toluene(C₇H₈), Styrene(C₈H₈), and alkaline mist of KOH, NaOH and LiOH.

Emergency treatment(See Section 8)

(A) In case the alkaline electrolyte happen to put into your eye;

Immediately wash your eyes for more than 15 minutes(in every nook and corner of eyelid, including inside of it) with a lot of water and then promptly receive medical treatment from a doctor(oculist).

(B) In case the alkaline electrolyte contact your skin;

Immediately wash it off with a lot of water. And quickly take off clothes and shoes polluted and then promptly receive medical treatment from a doctor.

(C) In case inhale a mixed steam or alkaline mist;

Avoid inhaling by standing on the windward side

If inhale, immediately wrap person in a blanket, keep quiet and move to another place where there is fresh air. Then carry out the inhalation of oxygen and also promptly receive medical treatment from a doctor.

SECTION VII – Precautions for Safe Handling and Use

Steps to be Taken in Case Material is Released or Spilled

Do not disassemble the module and cell. If disassemble the module and the cell, should be stored under water immediately and precaution that alkaline liquid leaked out of the module and cell.

Waste Disposal Method

Dispose of it based on the means instructed by car manufacturers or distributors. Insulate the output terminal of module or battery-pack during transportation. The discharged condition is preferable for disposal.

SECTION VIII – Control Measures

Respiratory Protection (Specify Type)

In the normal condition, it is not needed specifically.

Ventilation	Local Exhaust	Special
	Mechanical (General)	Other

Note

- The module battery should not be placed in a sealed vessel.
- The module battery requires ventilation during usage.

Protective Gloves	Rubber	Eye Protection Wear splash proof goggles
-------------------	--------	---

Note

- In the case of disassembling the cell and/or the module battery, protection against the anti-alkaline must be used.

Other Protective Clothing of Equipment	N/A
--	-----

Work/Hygienic Practices	N/A
-------------------------	-----