

LEXUS
GS 450h



Hybrid
2012 Model
2nd Generation
Emergency Response Guide



Foreword

In April 2006, Lexus released the 1st generation Lexus GS450h gasoline-electric hybrid vehicle in North America. To educate and assist emergency responders in the safe handling of Lexus GS450h technology, Lexus published the 2007 GS450h Emergency Response Guide.

With the release of the 2nd generation Lexus GS450h in March 2012, a new 2012 Lexus GS450h Emergency Response Guide was published for emergency responders. While many features from the 1st generation model are similar, emergency responders should recognize and understand the new, updated features of the 2nd generation GS450h covered in this guide.

High voltage electricity powers the electric motor, generator, air conditioning (A/C) compressor and inverter/converter. All other automotive electrical devices such as the head lights, radio, and gauges are powered from a separate 12 Volt auxiliary battery. Numerous safeguards have been designed into the GS450h to help ensure the high voltage, approximately 288 Volt, Nickel Metal Hydride (NiMH) Hybrid Vehicle (HV) battery pack is kept safe and secure in an accident.

The GS450h utilizes the following electrical systems:

- Maximum 650 Volts AC
- Nominal 288 Volts DC
- Maximum 46 Volts AC
- Nominal 12 Volts DC

2nd generation GS450h Features:

- Complete model change with a new exterior and interior design.
- A boost converter in the inverter/converter that boosts the available voltage to the electric motor to 650 Volts.
- A high voltage Hybrid Vehicle (HV) battery pack rated at 288 Volts.
- A high voltage motor driven Air Conditioning (A/C) compressor rated at 288 Volts.
- A body electrical system rated at 12 Volts, negative chassis ground.

- Supplemental Restraint System (SRS) – dual stage frontal airbags, knee airbags, front and rear seat side airbags, side curtain airbags and front and rear outside seat belt pretensioners.
- An Electric Power Steering (EPS) assist motor rated at 46 Volts.

High voltage electrical safety remains an important factor in the emergency handling of the GS450h Lexus Hybrid Drive. It is important to recognize and understand the disabling procedures and warnings throughout the guide.

Additional topics in the guide include:

- GS450h identification.
- Major Lexus Hybrid Drive component locations and descriptions.
- Extrication, fire, recovery, and additional emergency response information.
- Roadside assistance information.

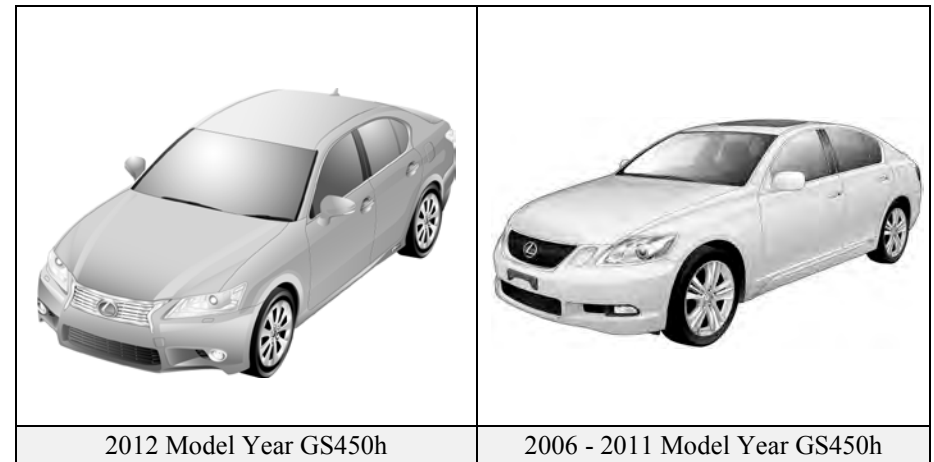

This guide is intended to assist emergency responders in the safe handling of a GS450h vehicle during an incident.

Table of Contents	Page
About the GS450h	1
GS450h Identification	2
Lexus Hybrid Drive Component Locations & Descriptions	5
Entry & Start System	8
Lexus Hybrid Drive Operation	11
Hybrid Vehicle (HV) Battery Pack	12
46 Volt System	13
Low Voltage Battery	14
High Voltage Safety	15
SRS Airbags & Seat Belt Pretensioners	16
Emergency Response	18
Extrication	18
Fire	24
Overhaul	25
Recovering/Recycling of NiMH HV Battery Pack	26
Spills	26
First Aid	26
Submersion	27
Roadside Assistance	28
Product Safety Data Sheet	32

About the GS450h

The GS450h 4-door sedan joins the LS600h/ LS600h L, RX450h and CT200h as a hybrid model for Lexus. Lexus Hybrid Drive means that the vehicle contains a gasoline engine and an electric motor for power. The two hybrid power sources are stored on board the vehicle:

1. Gasoline stored in the fuel tank for the gasoline engine.
2. Electricity stored in a high voltage Hybrid Vehicle (HV) battery pack for the electric motor.

The result of combining these two power sources is improved fuel economy and reduced emissions. The gasoline engine also powers an electric generator to recharge the battery pack; unlike a pure all electric vehicle, the GS450h never needs to be recharged from an external electric power source.

Depending on the driving conditions one or both sources are used to power the vehicle. The following illustration demonstrates how the GS450h operates in various driving modes.

- ❶ During light acceleration at low speeds, the vehicle is powered by the electric motor. The gasoline engine is shut off.
- ❷ During normal driving, the vehicle is powered mainly by the gasoline engine. The gasoline engine also powers the generator to recharge the battery pack and to drive the motor.

- ❸ During full acceleration, such as climbing a hill, both the gasoline engine and the electric motor power the vehicle.
- ❹ During deceleration, such as when braking, the vehicle regenerates kinetic energy from the rear wheels to produce electricity that recharges the battery pack.
- ❺ While the vehicle is stopped, the gasoline engine and electric motor are off; however the vehicle remains on and operational.

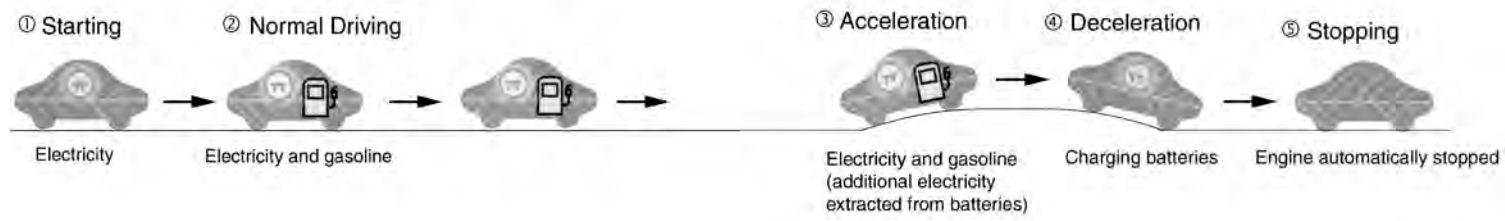

GS450h Identification

In appearance, the 2012 model year GS450h is nearly identical to the conventional, non-hybrid Lexus GS350/250. The GS450h is a 4-door sedan. Exterior, interior, and engine compartment illustrations are provided to assist in identification.

The alphanumeric 17 character Vehicle Identification Number (VIN) is provided in the front windshield cowl, engine compartment, and on the left side B pillar.

Example VIN: JTHBS1BL0D5000101
JTHBS5BL005000101

A GS450h is identified by the first 8 alphanumeric characters **JTHBS1BL** or **JTHBS5BL**.

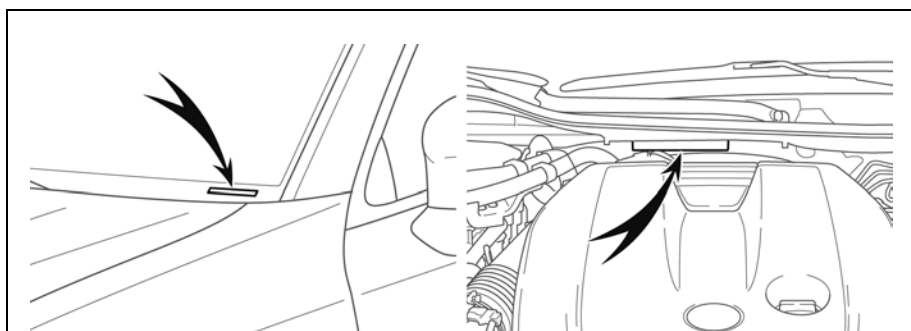

This illustration is for an LHD model

Left Side Windshield Cowl and Engine Compartment Cowl

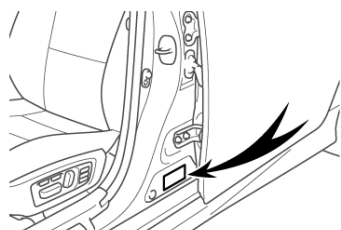

Left Side B Pillar

Exterior

- 1  **LEXUS** and **GS 450h** logos on the trunk.
- 2 **HYBRID** logo on the rocker moldings.
- 3 Gasoline fuel filler door located on the left side rear quarter panel.

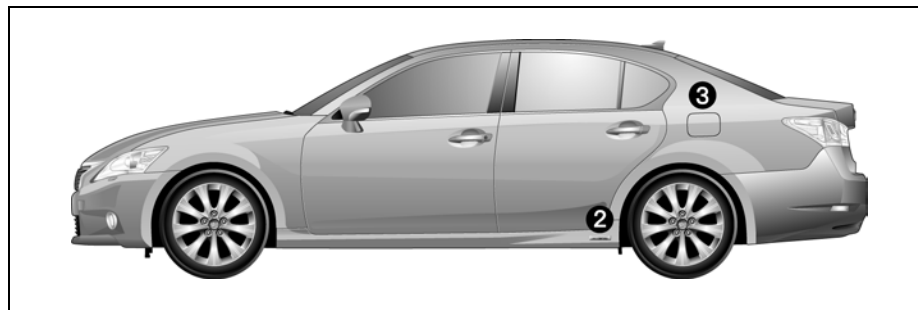

Exterior Left Side View

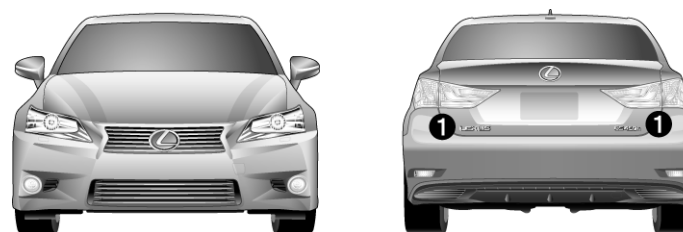

Exterior Front and Rear View

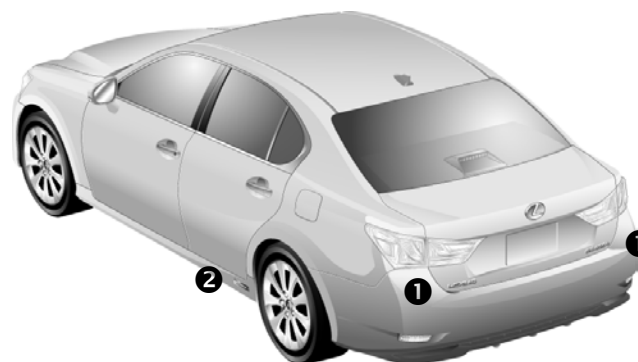

Exterior Rear and Left Side View

GS450h Identification (Continued)

Interior

- ④ The instrument cluster (hybrid system indicator, **READY** indicator, and warning lights) located in the dash behind the steering wheel, is different than the one on the conventional, non-hybrid GS350/250.
- ⑤ A switchable gauge in the instrument cluster showing either a hybrid system indicator or a tachometer depending on driving mode.

NOTE:

If the vehicle is shut off, the instrument cluster gauges will be “blacked out”, not illuminated.

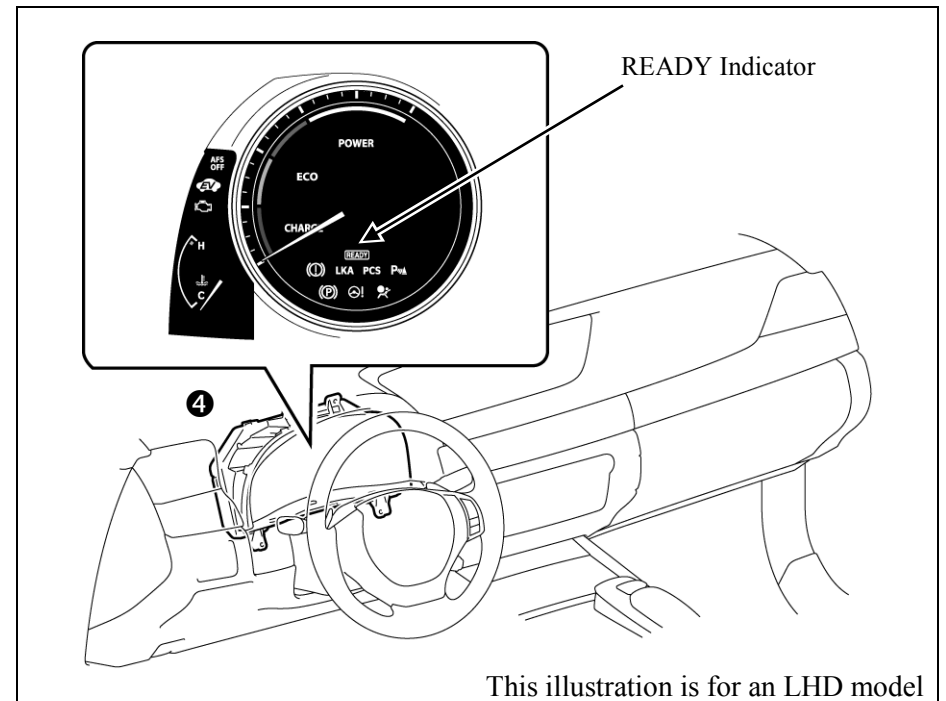
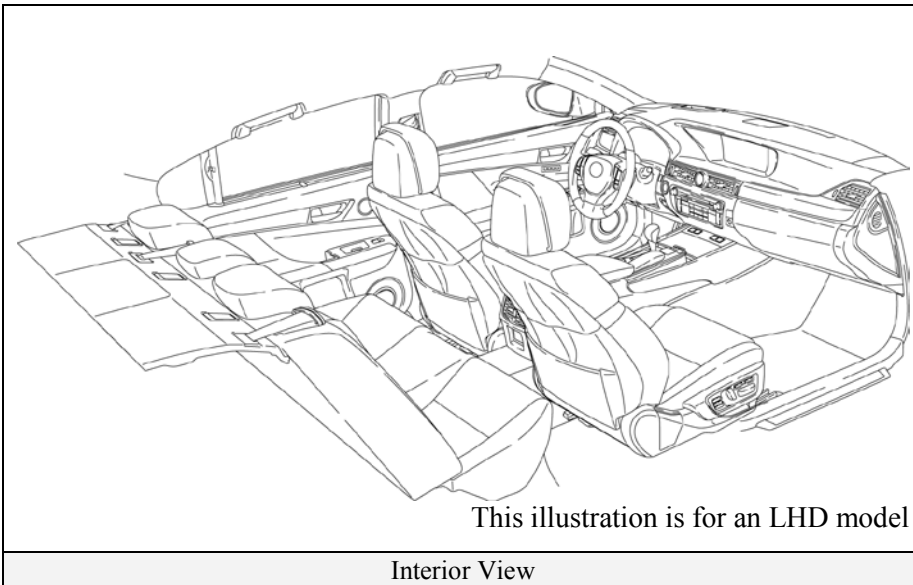

Instrument Cluster View

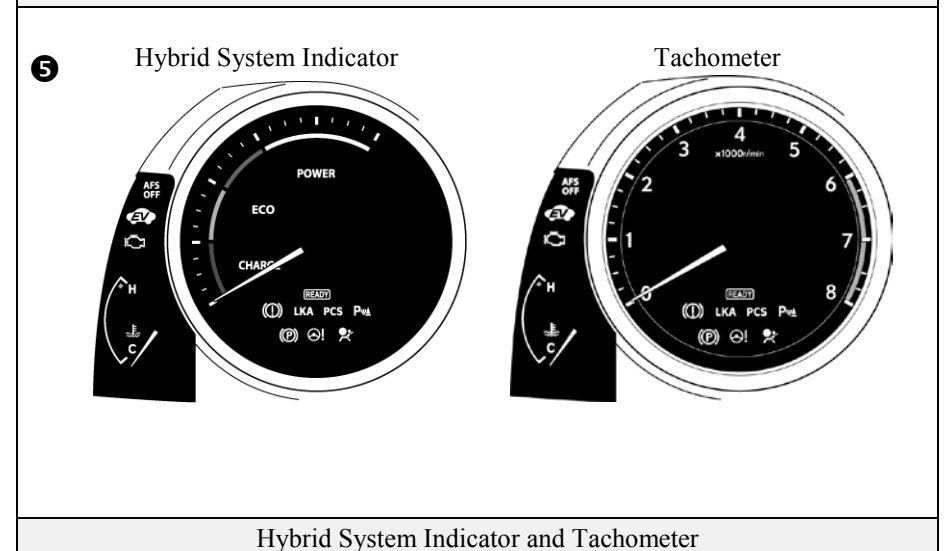

GS450h Identification (Continued)

Engine Compartment

- ⑥ 3.5-liter aluminum alloy gasoline engine.
- ⑦ Logo on the plastic engine cover.

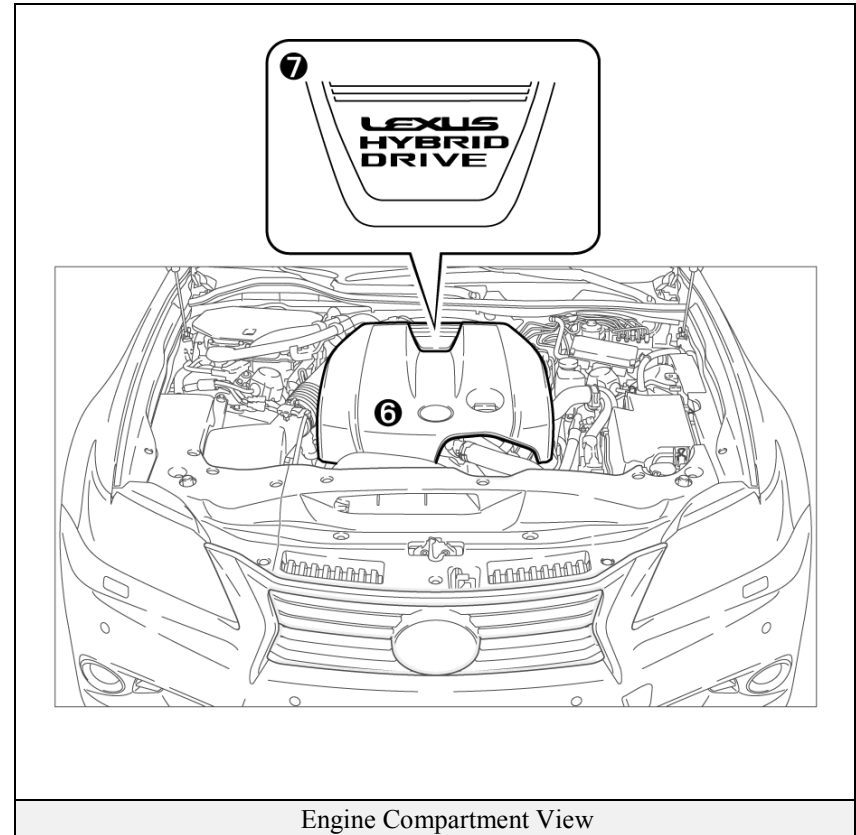

Lexus Hybrid Drive Component Locations & Descriptions

Component	Location	Description
12 Volt Auxiliary Battery ❶	Left Side of Trunk	A lead-acid battery that supplies power to the low voltage devices.
Hybrid Vehicle (HV) Battery Pack ❷	Trunk Area, Mounted behind Rear Seat	288 Volt Nickel Metal Hydride (NiMH) battery pack consisting of 40 low voltage (7.2 Volt) modules connected in series.
Power Cables ❸	Undercarriage and Engine Compartment	Orange colored power cables carry high voltage Direct Current (DC) between the HV battery pack, inverter/converter, and A/C compressor. These cables also carry 3-phase Alternating Current (AC) between the inverter/converter, electric motor, and generator.
Inverter/Converter ❹	Engine Compartment	Boosts and inverts the high voltage electricity from the HV battery pack to 3-phase AC electricity that drives the electric motor. The inverter/converter also converts AC electricity from the electric generator and electric motor (regenerative braking) to DC that recharges the HV battery pack.
Gasoline Engine ❺	Engine Compartment	Provides two functions: 1) Powers vehicle. 2) Powers generator to recharge the HV battery pack. The engine is started and stopped under control of the vehicle computer.
Electric Motor ❻	Transmission	3-phase high voltage AC permanent magnet electric motor contained in the transmission and drives the rear wheels through the propeller shaft.
Electric Generator ❼	Transmission	3-phase high voltage AC generator that is contained in the transmission and recharges the HV battery pack.

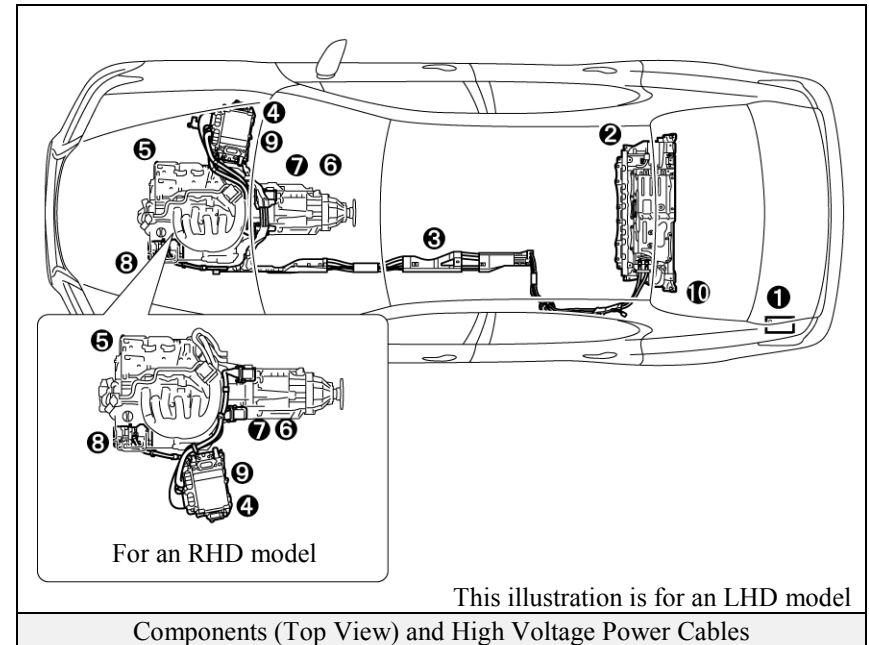
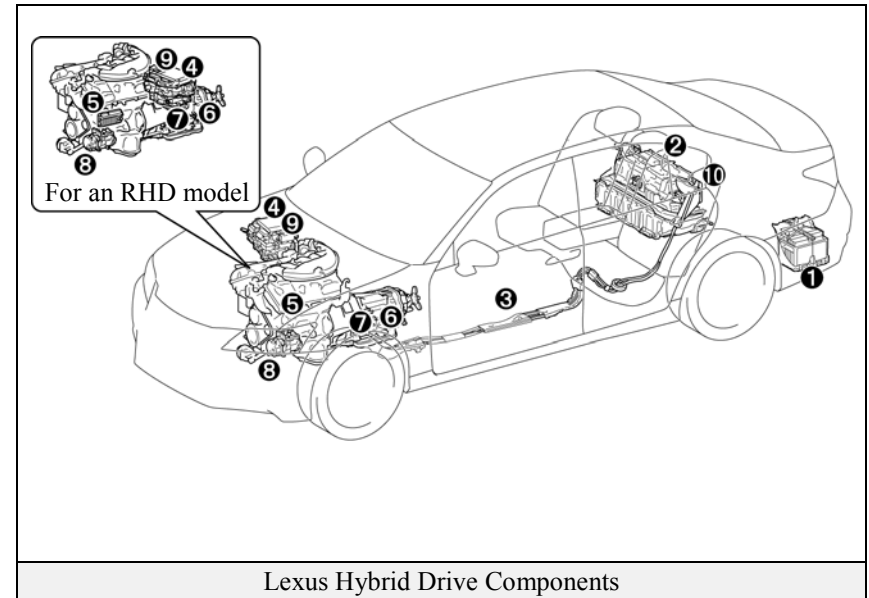

Lexus Hybrid Drive Component Locations & Descriptions (Continued)

Component	Location	Description
A/C Compressor (with Inverter) ⑧	Engine Compartment	3-phase high voltage AC electrically driven motor compressor.
DC-DC Converter for 12 Volt Auxiliary Battery ⑨	Engine Compartment	Converts 288 Volts from the HV battery pack to 12 Volts for low voltage vehicle power.
DC-DC Converter for EPS ⑩	On HV battery pack	Converts 288 Volts from the HV battery pack to 46 Volts for EPS. Dull yellow colored sheathing identifies 46 Volts wires that are routed under the vehicle body to power the EPS.
Fuel Tank and Fuel Line ⑪	Undercarriage and Left Side and Center	The fuel tank provides gasoline via a fuel line to the engine. The fuel line is routed along the left side and center tunnel under the floor pan.

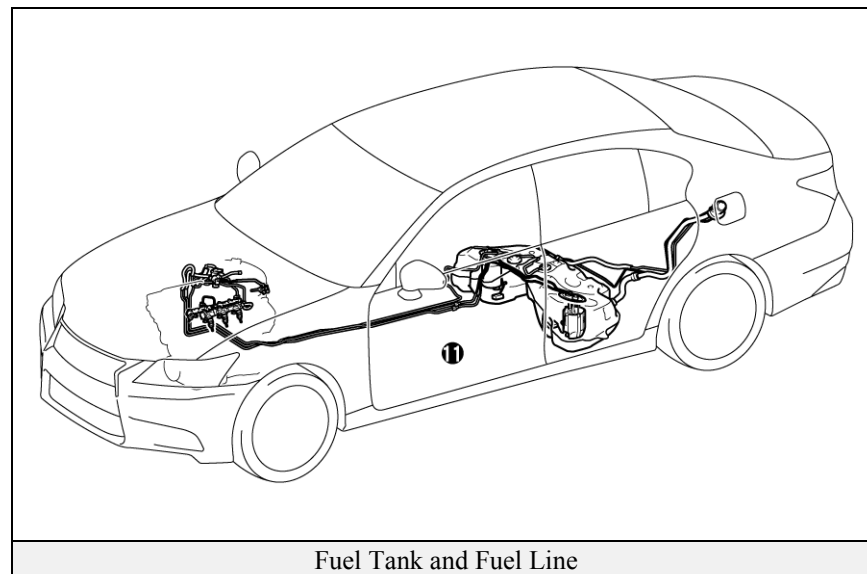

Lexus Hybrid Drive Component Locations & Descriptions (Continued)

Key Specifications:

Gasoline Engine:	292 ps (215 kW), 3.5-liter Aluminum Alloy Engine
Electric Motor:	200 ps (147 kW), Permanent Magnet Motor
Transmission:	Automatic Only
HV Battery:	288 Volt Sealed NiMH-Battery
Curb Weight:	4,012 – 4,211 lbs/1,820 - 1910 kg
Fuel Tank:	17.4 gals/66.0 liters
Frame Material:	Steel Unibody
Body Material:	Steel Panels except for Aluminum Hood
Seating Capacity:	5 passenger

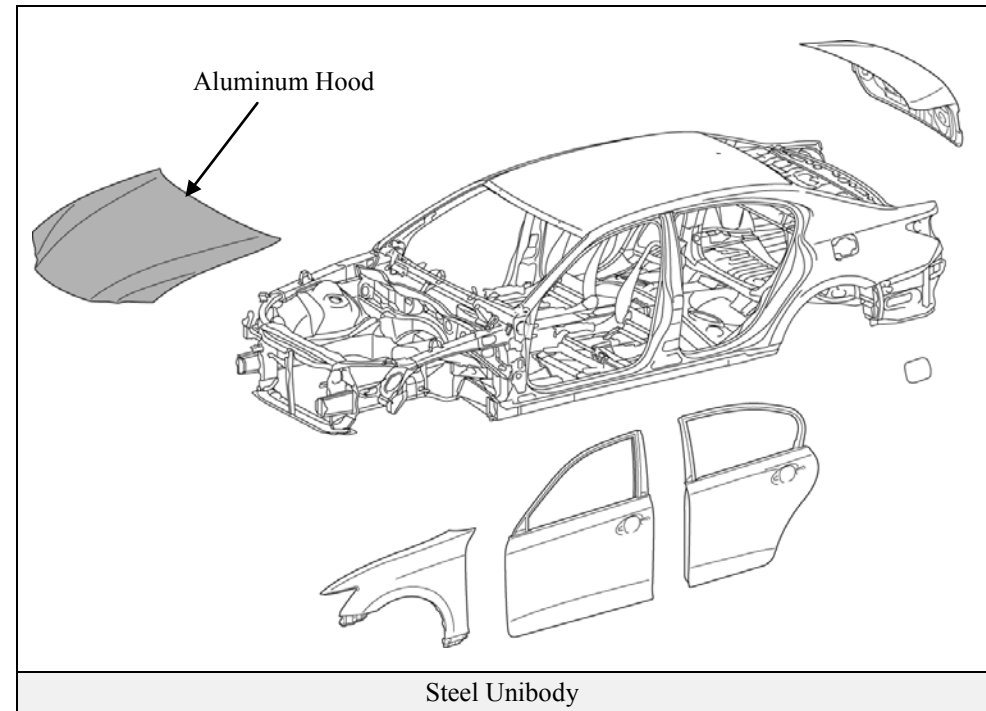

Entry & Start System

The GS450h entry system consists of a key transceiver that communicates bi-directionally, enabling the vehicle to recognize the key in proximity to the vehicle. Once recognized, the key will allow the user to lock and unlock the doors without pushing key buttons, and start the vehicle without inserting it into an ignition switch.

Key features:

- Passive (remote) function to lock/unlock the doors, unlock the trunk, and start the vehicle.
- Wireless transmitter buttons to lock/unlock all 4 doors and unlock the trunk.
- Hidden metal cut key to lock/unlock the doors, glove box, and unlock the trunk.

The GS450h is equipped with 2 types of keys:

- key (fob)
- Card key (optional)

The card key is designed to be stored in a wallet and has all the same functions as the key (fob), except push buttons.

Door (Lock/Unlock)

There are several methods available to lock/unlock the doors.

- Pushing the key lock/unlock buttons will lock/unlock all doors.(Except Korea)
- Pushing the key lock button will lock all doors. Pushing the key unlock button once unlock the driver door, twice unlocks all doors.(For Korea)
- Touching the unlock touch sensor on the backside of the any exterior door handle, with the key in close proximity to the vehicle, unlocks the doors. Touching the lock touch sensor on the frontside of the any exterior door handle locks the doors.
- Inserting the hidden metal cut key in the driver door lock and turning clockwise (for LHD model) or counterclockwise (for RHD model) once unlocks the driver door, twice unlocks all doors. To lock all doors turn the key counterclockwise (for LHD model) or clockwise (for RHD model) once. Only the driver door contains an exterior door lock for the metal cut key.

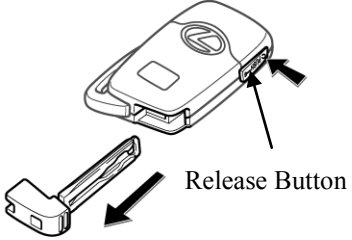
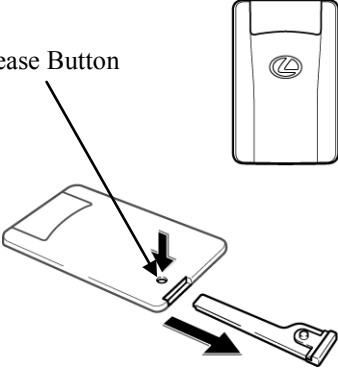
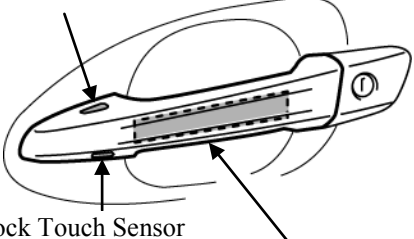
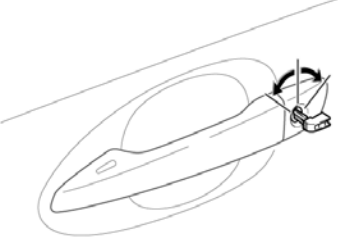
 <p>For Europe and China</p> <p>Except Europe and China</p>	 <p>Release Button</p>
<p>Key (Fob)</p>	<p>Hidden Metal Cut Key for Door Lock</p>
 <p>Release Button</p>	 <p>Lock Touch Sensor</p> <p>Lock Touch Sensor</p> <p>Unlock Touch Sensor</p> <p>This illustration is for an LHD model</p>
<p>Optional Card Key and Hidden Metal Cut Key for Door Lock</p>	<p>Driver Door Unlock Touch Sensor and Lock Touch Sensor</p>
 <p>Use the Hidden Metal Cut Key</p> <p>This illustration is for an LHD model</p>	<p>Front Driver Door Lock</p>

Entry & Start System (Continued)

Trunk (Unlock)

There are several methods available to open the trunk.

- Pushing the key trunk opener button.
- Pushing the trunk opener switch on the lower dash panel.
- Pushing the trunk opener switch with the key in proximity to the vehicle.

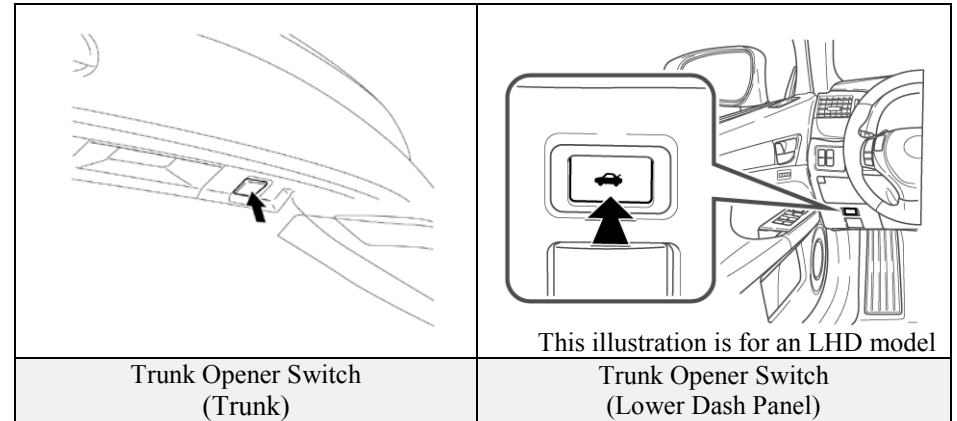

Entry & Start System (Continued)

Vehicle Starting/Stopping

The key has replaced the conventional metal cut key, and the power button has replaced the ignition switch. The key only needs to be in proximity to the vehicle to allow the system to function.

- With the brake pedal released, the first push of the power button operates the accessory mode, the second push operates the ignition-on mode, and the third push turns the ignition off again.

Ignition Mode Sequence (brake pedal released):

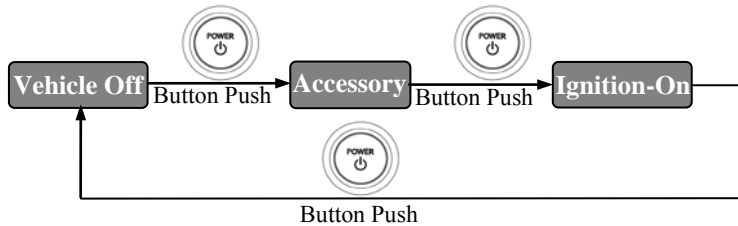

- Starting the vehicle takes priority over all other ignition modes and is accomplished by depressing the brake pedal and pushing the power button once. To verify the vehicle has started, check that the **READY** indicator is illuminated in the instrument cluster.
- If the internal key battery is dead, use the following method to start the vehicle.
 - Touch the Lexus emblem side of the key to the power button.
 - Within the 10 seconds after the buzzer sounds, push the power button with the brake pedal depressed (the **READY** indicator will illuminate).
- Once the vehicle has started and is on and operational (**READY-ON**), the vehicle is shut off by bringing the vehicle to a complete stop, placing the gearshift lever in **Park** and then depressing the power button once.
- To shut off the vehicle before coming to a stop in an emergency, push and hold down the power button for more than 2 seconds or push the power button 3 times or more in a row. This procedure may be useful at an accident scene in which the **READY** indicator is on, **Park** cannot be selected, and the drive wheels remain in motion.

Ignition Mode	Multi-information Display (Instrument Cluster)
Off	-
Accessory	POWER ON
Ignition-On	POWER ON
Brake Pedal Depressed	Key Symbol
Vehicle Started (READY-ON)	-
Malfunction	Warning Message

<p>This illustration is for an LHD model</p>	<p>This illustration is for an LHD model</p>
POWER ON & Key Symbol (Multi-information Display)	Ignition Modes (Brake Pedal Released)
<p>This illustration is for an LHD model</p>	
Starting Sequence (Brake Pedal Depressed)	Key Recognition (When Key Battery is Dead)

Lexus Hybrid Drive Operation

Once the **READY** indicator is illuminated in the instrument cluster, the vehicle may be driven. However, the gasoline engine does not idle like a typical automobile and will start and stop automatically. It is important to recognize and understand the **READY** indicator provided in the instrument cluster. When lit, it informs the driver that the vehicle is on and operational even though the gasoline engine may be off and the engine compartment is silent.

Vehicle Operation

- With the GS450h, the gasoline engine may stop and start at any time while the **READY** indicator is on.
- Never assume that the vehicle is shut off just because the engine is off. Always look for the **READY** indicator status. The vehicle is shut off when the **READY** indicator is off.
- The vehicle may be powered by:
 1. The electric motor only.
 2. A combination of both the electric motor and the gasoline engine.
- The vehicle computer determines the mode in which the vehicle operates in order to help enhance fuel economy and reduce emissions. Four features on the 2012 GS450h are EV (Electric Vehicle) mode, ECO (Economy) mode, Sport mode, and Snow mode:
 1. EV Mode: When activated, and certain conditions have been met, the vehicle operates with the electric motor powered by the HV battery.
 2. ECO Mode: When activated, ECO mode helps enhance fuel economy on trips that involve frequent braking and acceleration.
 3. Sport Mode: When activated, Sport mode optimizes acceleration feel by increasing the power output more quickly at the beginning of accelerator pedal operation. When Sport mode is selected, the tachometer is displayed in the instrument cluster instead of the Hybrid System Indicator.
 4. Snow mode: When activated, Snow mode helps accelerator pedal operation performance and stability when accelerating from a stop on slippery surfaces such as a snowy road.

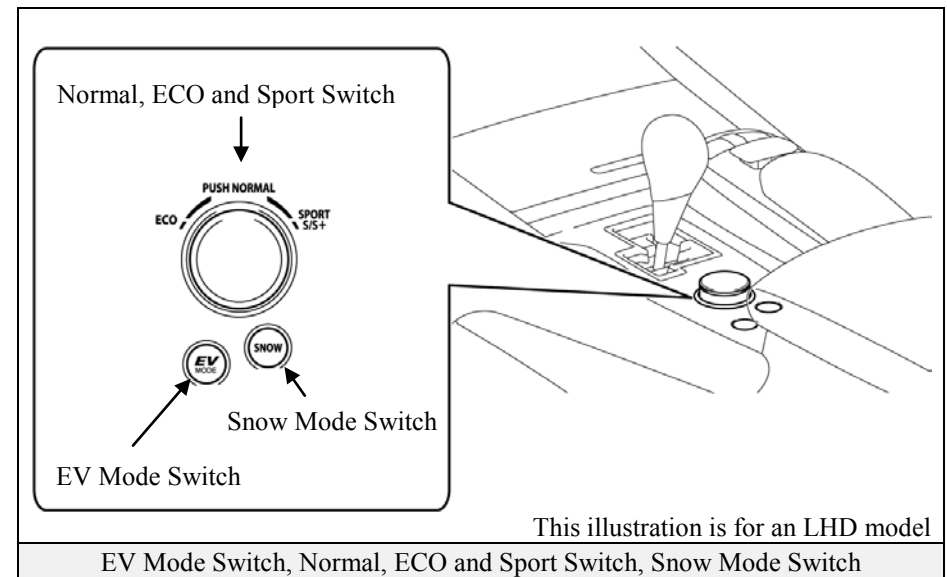
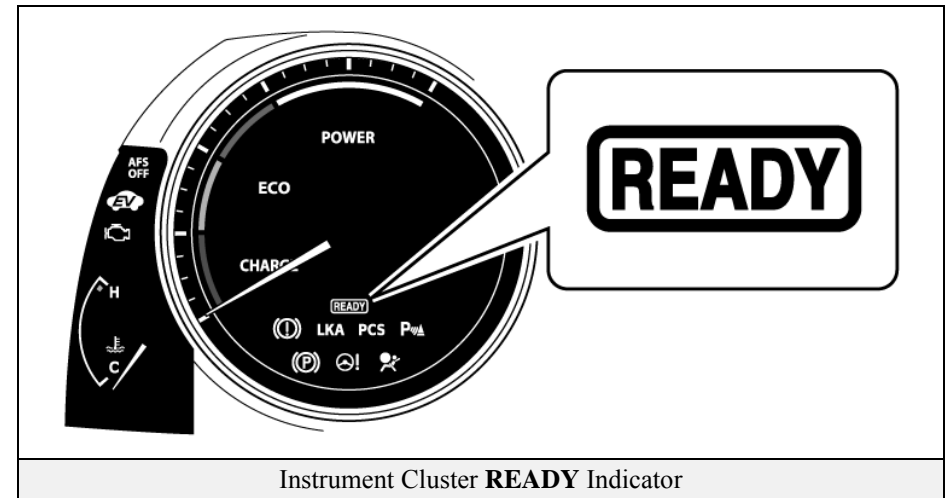

Hybrid Vehicle (HV) Battery Pack

The GS450h features a high voltage Hybrid Vehicle (HV) battery pack that contains sealed Nickel Metal Hydride (NiMH) battery modules.

HV Battery Pack

- The HV battery pack is enclosed in a metal case and is rigidly mounted to the trunk area behind the rear seat. The metal case is isolated from high voltage and concealed by fabric covers in the trunk.
- The HV battery pack consists of 40 low voltage (7.2 Volt) NiMH battery modules connected in series to produce approximately 288 Volts. Each NiMH battery module is non-spillable and sealed in a metal case.
- The electrolyte used in the NiMH battery module is an alkaline mixture of potassium and sodium hydroxide. The electrolyte is absorbed into the battery cell plates and will not normally leak, even in a collision.

HV Battery Pack	
Battery pack voltage	288 V
Number of NiMH battery modules in the pack	40
NiMH battery module voltage	7.2 V
NiMH battery module dimensions	10.9 x 0.8 x 4.2 in (276 x 20 x 106 mm)
NiMH module weight	2.3 lbs (1.0 kg)
NiMH battery pack dimensions	37 x 14.5 x 15.3 in (940 x 370 x 390 mm)
NiMH battery pack weight	140 lbs (63 kg)

Note: Values in inches have been rounded

Components Powered by the HV Battery Pack

- Electric Motor
- Power Cables
- Electric Generator
- DC-DC Converter for 12 Volt Auxiliary Battery
- DC-DC Converter for EPS
- Inverter/Converter
- A/C Compressor

HV Battery Pack Recycling

- The HV battery pack is recyclable. Contact the nearest Lexus dealer.

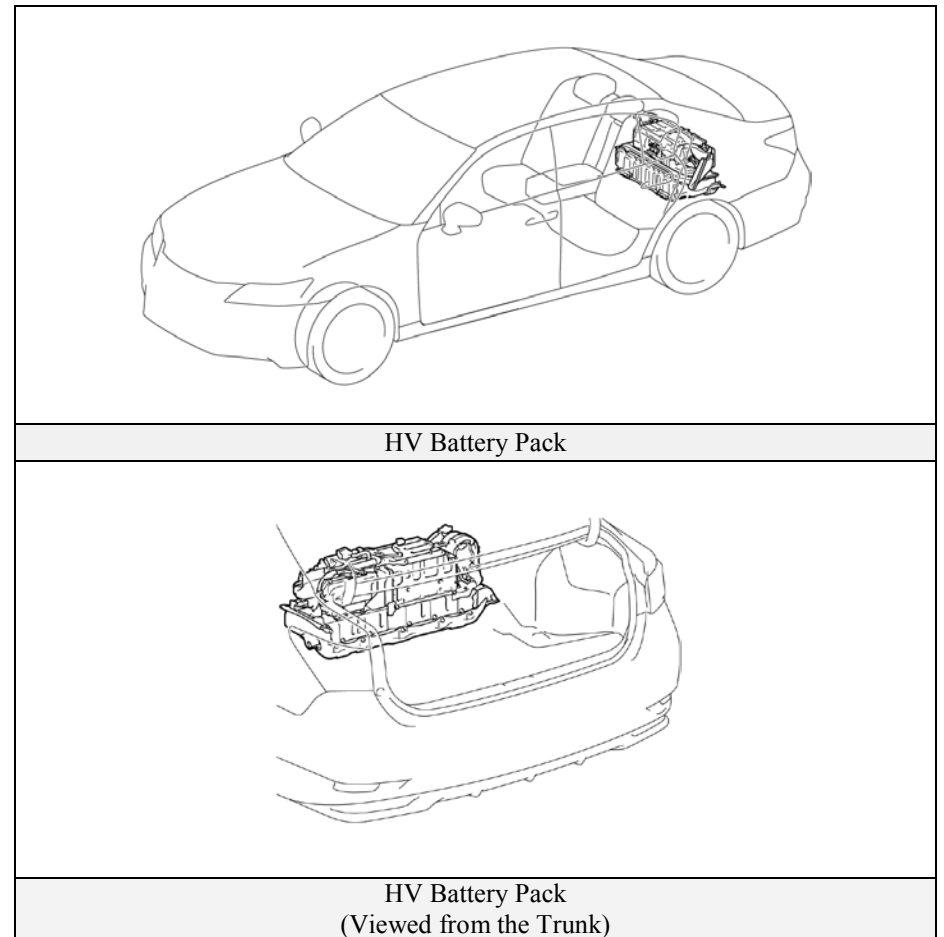

46 Volt System

The GS450h is equipped with a 46 Volt AC electrical system that powers the Electric Power Steering (EPS) assist motor in the engine compartment.

- 46 Volt electrical system wires are bundled in amber sheathing for identification.
- The 46 Volt electrical system does not contain a storage battery. It is powered by converting high voltage battery power. The wires are routed underneath the vehicle from the HV battery pack DC-DC converter.
- If the HV battery pack malfunctions, backup power is provided to the EPS motor by boosting the 12 Volt electrical system.

NOTE:

46 Volts has a higher arc potential than 12 Volts DC.

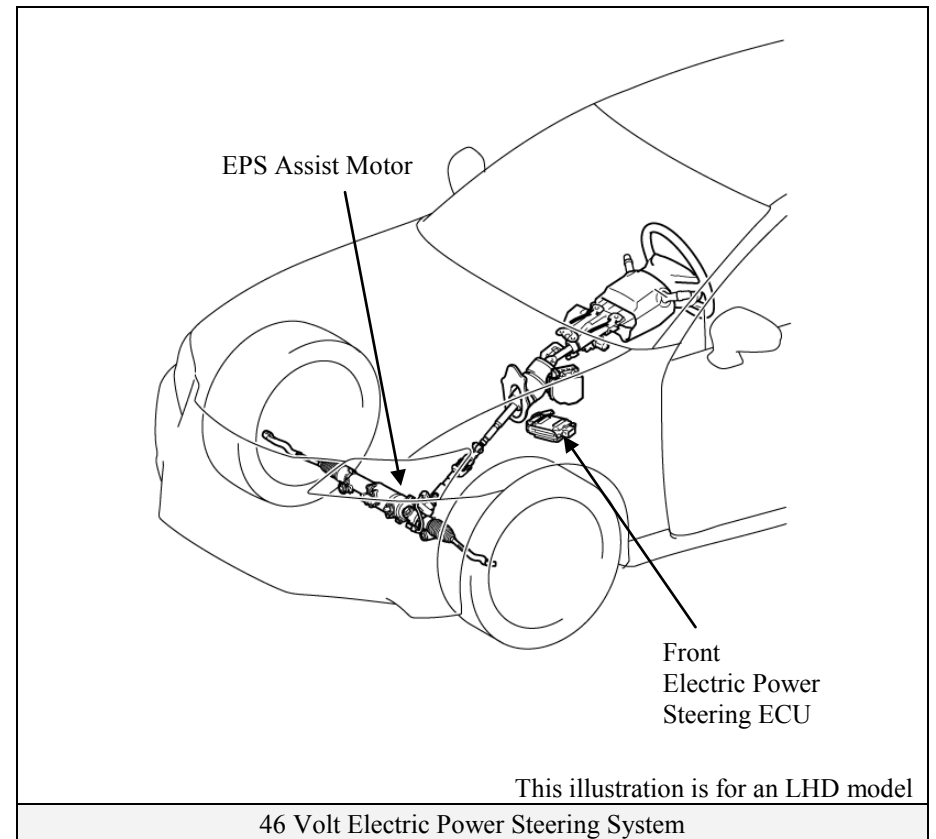



Low Voltage Battery

Auxiliary Battery

- The GS450h contains a sealed lead-acid 12 Volt battery. This 12 Volt auxiliary battery powers the vehicle electrical system similar to a conventional vehicle. As with other conventional vehicles, the negative terminal of the auxiliary battery is grounded to the metal chassis of the vehicle.
- The auxiliary battery is located in the trunk. It is concealed by a fabric cover on the driver side in the rear quarter panel well.

NOTE:

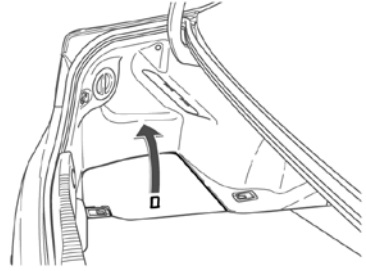
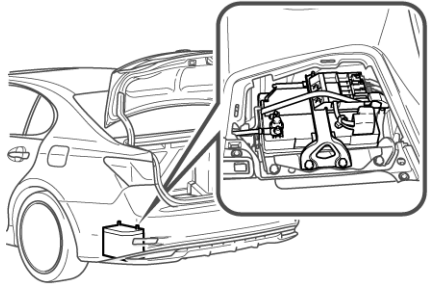
An under hood label shows the location of the HV battery (traction battery) and 12 Volt auxiliary battery.

	
<p>Remove Luggage Compartment Side Trim Cover</p>	<p>12 Volt Auxiliary Battery Mounted in Trunk</p>
 <p style="text-align: center;">Battery Location Label</p>	

High Voltage Safety

The HV battery pack powers the high voltage electrical system with DC electricity. Positive and negative orange colored high voltage power cables are routed from the battery pack, under the vehicle floor pan, routed along the propeller shaft and transmission tunnel to the inverter/converter. The inverter/converter contains a circuit that boosts the HV battery voltage from 288 to 650 Volts DC. The inverter/converter creates 3-phase AC to power the motor. Power cables are routed from the inverter/converter to each high voltage motor (electric motor, electric generator, and A/C compressor). The following systems are intended to help keep occupants in the vehicle and emergency responders safe from high voltage electricity:

High Voltage Safety System

- A high voltage fuse ❶ provides short circuit protection in the HV battery pack.
- Positive and negative high voltage power cables ❷ connected to the HV battery pack are controlled by 12 Volt normally open relays ❸. When the vehicle is shut off, the relays stop electrical flow from leaving the HV battery pack.

⚠️ WARNING:

The high voltage system may remain powered for up to 10 minutes after the vehicle is shut off or disabled. To prevent serious injury or death from severe burns or electric shock, avoid touching, cutting, or breaching any orange high voltage power cable or high voltage component.

- Both positive and negative power cables ❷ are insulated from the metal body. High voltage electricity flows through these cables and not through the metal vehicle body. The metal vehicle body is safe to touch because it is insulated from the high voltage components.

- A ground fault monitor ❹ continuously monitors for high voltage leakage to the metal chassis while the vehicle is running. If a malfunction is detected, the hybrid vehicle computer ❹ will illuminate the master warning light ⚠️ in the instrument cluster and indicate “CHECK HYBRID SYSTEM” on the multi-information display.

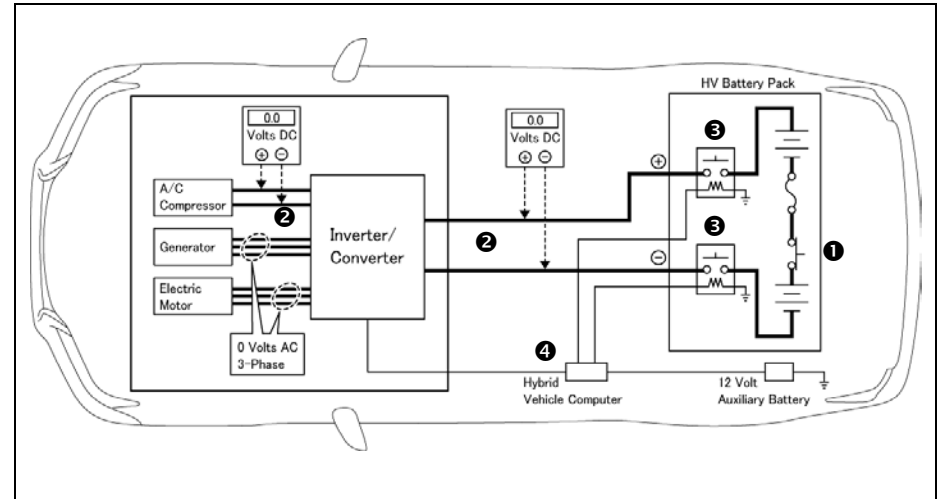

High Voltage Safety System – Vehicle Shut Off (**READY-OFF**)

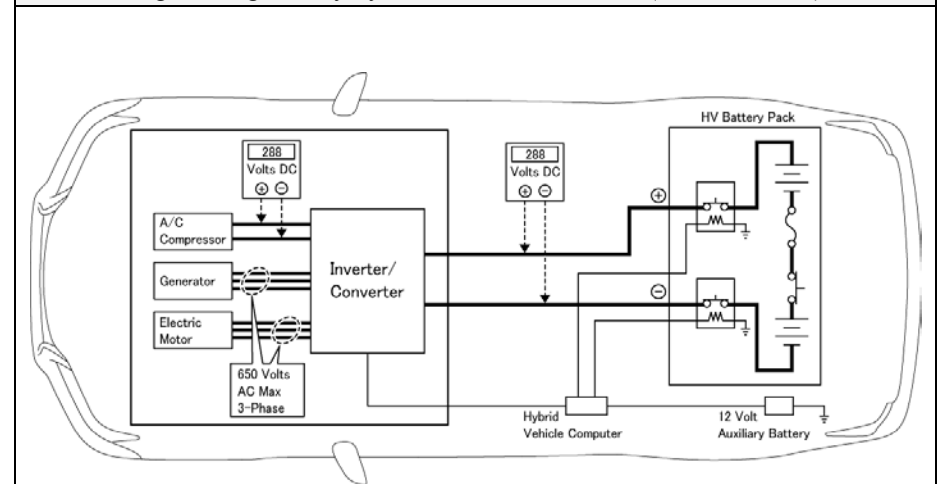

High Voltage Safety System – Vehicle On and Operational (**READY-ON**)

SRS Airbags & Seat Belt Pretensioners

Standard Equipment

- Electronic frontal impact sensors (2) are mounted in the engine compartment ① as illustrated.
- Front seat belt pretensioners are mounted near the base of the B-pillars ②.
- Outside rear seat belt pretensioners are mounted near the C-pillar on the rear seatbacks. ③
- A frontal dual stage driver airbag ④ is mounted in the steering wheel hub.
- A frontal dual stage passenger airbag ⑤ is integrated into the dashboard and deploys through the top of the dashboard.
- The SRS computer ⑥, which contains an impact sensor, is mounted on the floor pan underneath the center console.
- Front electronic side impact sensors (2) are mounted near the base of the B-pillars. ⑦
- Rear electronic side impact sensors (2) are mounted near the base of the C-pillars. ⑧
- Front seat side airbags ⑨ are mounted in the front seatbacks.
- Rear seat side airbags ⑩ are mounted rear seatbacks.
- Side curtain airbags ⑪ are mounted along the outer edge inside the roof rails.
- Front knee airbags (2) ⑫ are mounted on the lower portion of the dash.

Optional Equipment

- The optional pre-crash safety system contains a radar sensory system and an electric motor-pyrotechnic pretensioner system. During a pre-collision event, an electric motor in the pretensioners retracts the front seatbelts. When conditions stabilize the electric motor will reverse itself. When the airbags deploy, or as necessary, the pyrotechnic pretensioners function normally.

WARNING:

The SRS may remain powered for up to 90 seconds after the vehicle is shut off or disabled. To prevent serious injury or death from unintentional SRS deployment, avoid breaching the SRS components.

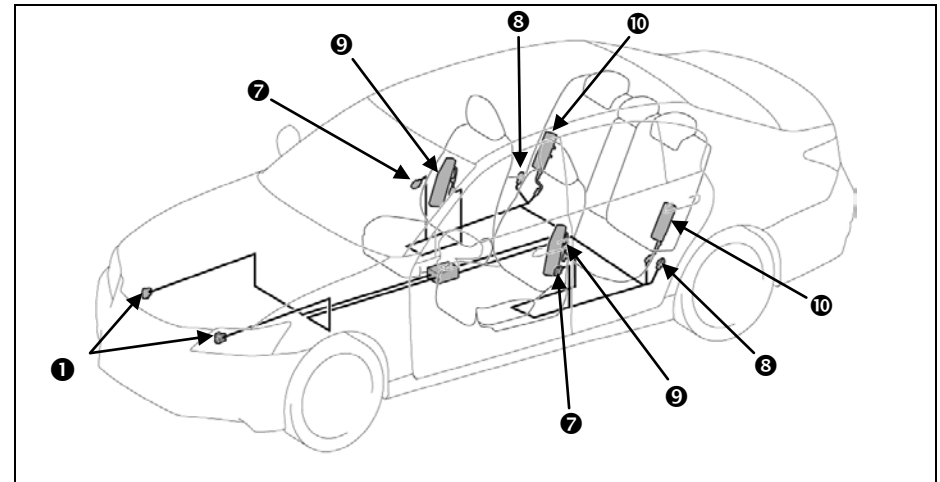

Electronic Impact Sensors and Side Airbags

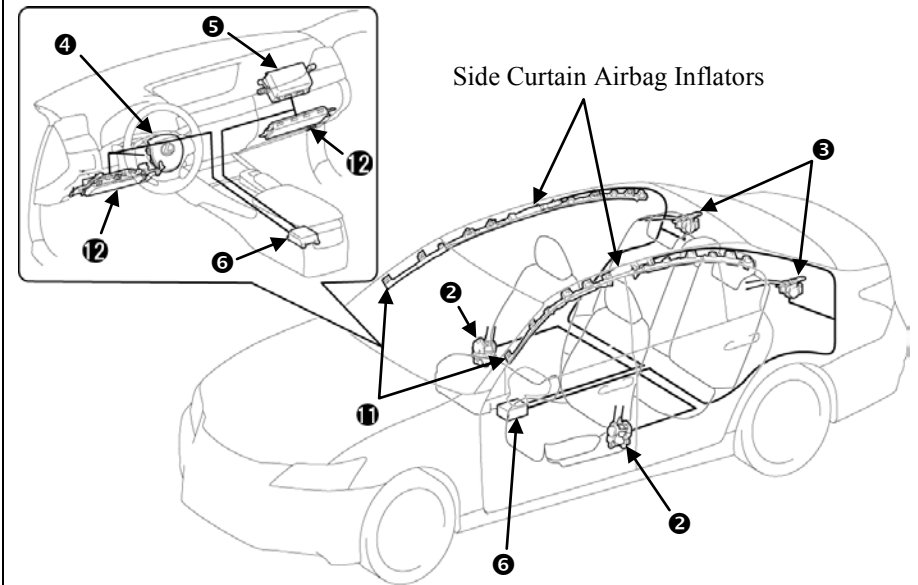

This illustration is for an LHD model

Standard Frontal Airbags, Seat Belt Pretensioners, Knee Airbags,
Side Curtain Airbags

SRS Airbags & Seat Belt Pretensioners (Continued)

Standard Equipment (Continued)

NOTE:

The front seatback mounted side airbags and the side curtain airbags may deploy independently of each other.

The knee airbags deploy simultaneously with the frontal airbags and seat belt pretensioners.

The GS450h is equipped with a standard front passenger occupant classification system that may prohibit the deployment of the front passenger frontal airbag, knee airbag, and seat belt pretensioner. If the front passenger occupant classification system prohibits deployment during an SRS event, the front passenger SRS will not re-arm nor deploy.

Electronic side impact sensors are installed near the base of the B-pillar and C-pillar to aid in side collision detection accuracy.

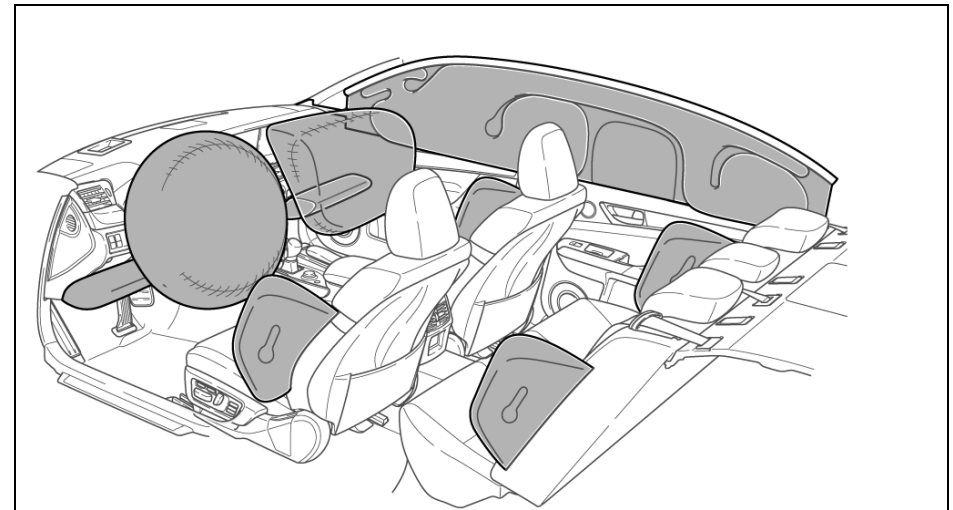

This illustration is for an LHD model

Frontal, Knee, Front and Rear Seatback Mounted Side, Side Curtain Airbags

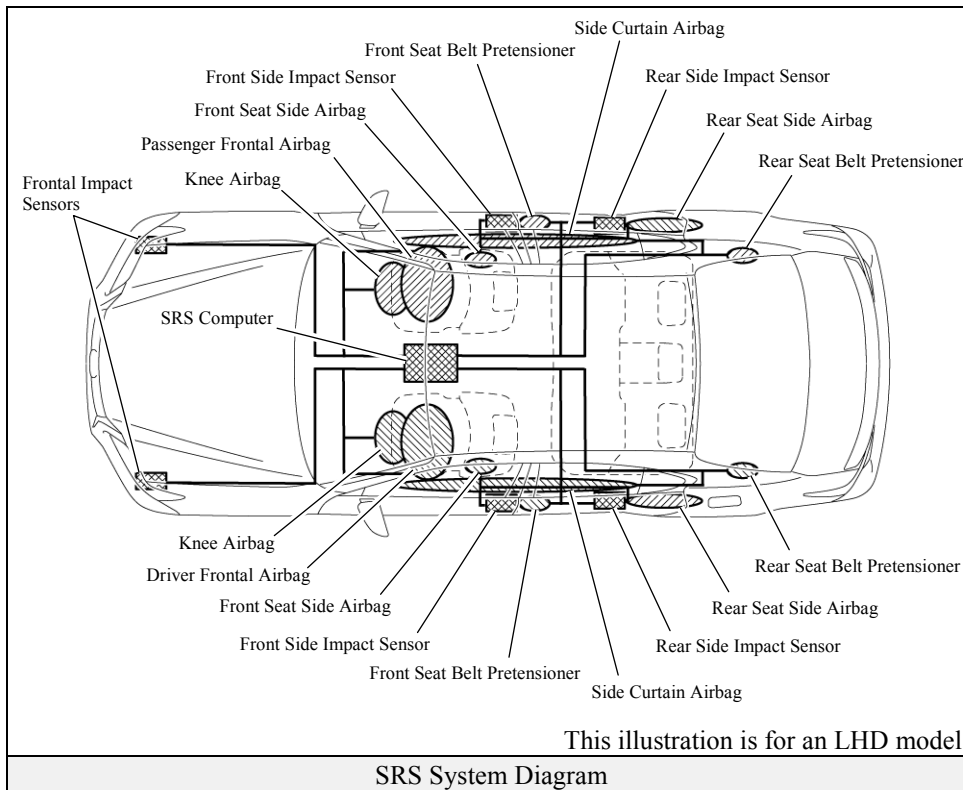

This illustration is for an LHD model

SRS System Diagram

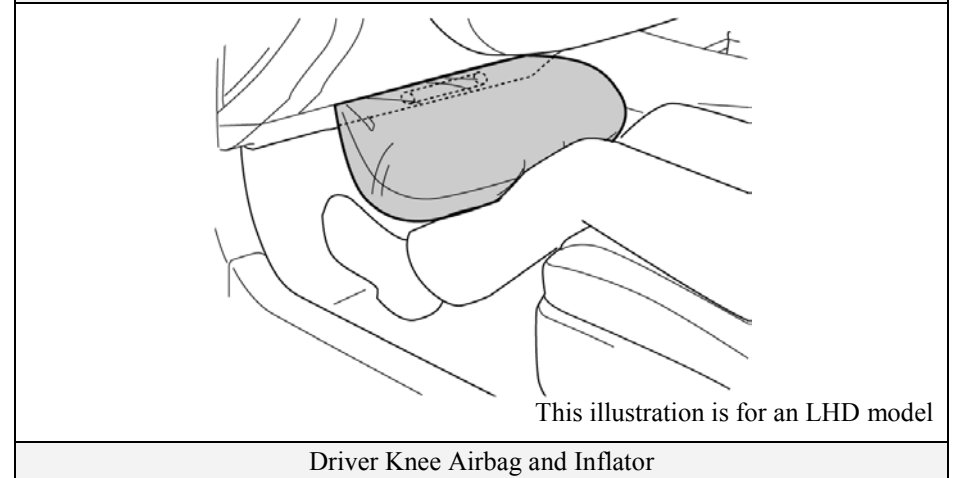

This illustration is for an LHD model

Driver Knee Airbag and Inflator

Emergency Response

On arrival, emergency responders should follow their standard operating procedures for vehicle incidents. Emergencies involving the GS450h may be handled like other automobiles except as noted in these guidelines for Extrication, Fire, Overhaul, Recovery, Spills, First Aid, and Submersion.

WARNING:

- *Never assume the GS450h is shut off simply because it is silent.*
- *Always observe the instrument cluster for the **READY** indicator status to verify whether the vehicle is on or shut off. The vehicle is shut off when the **READY** indicator is off.*
- *Failure to shut off the vehicle before emergency response procedures are performed may result in serious injury or death from the unintentional deployment of the SRS or severe burns and electric shock from the high voltage electrical system.*

Extrication

• Immobilize Vehicle

Chock wheels and set the parking brake.
Move the shift lever to the **Park** position.

NOTE:

The GS450h utilizes a push/pull parking brake switch that electromechanically sets/releases the rear parking brakes.

- To set/release, push/pull the parking brake switch located on the dash to the right side of the steering column (refer to illustration).
- If the AUTO button is set and illuminated, the parking brake will automatically set when the vehicle is shifted to the **Park** position.
- To verify that the parking brake is set, confirm that the parking brake indicator light illuminates on the instrument cluster (refer to illustration).

The parking brake indicator light will turn off after approximately 15 seconds.

• Disable Vehicle

Performing either of the following two procedures will shut the vehicle off and disable the HV battery pack, SRS, and gasoline fuel pump.

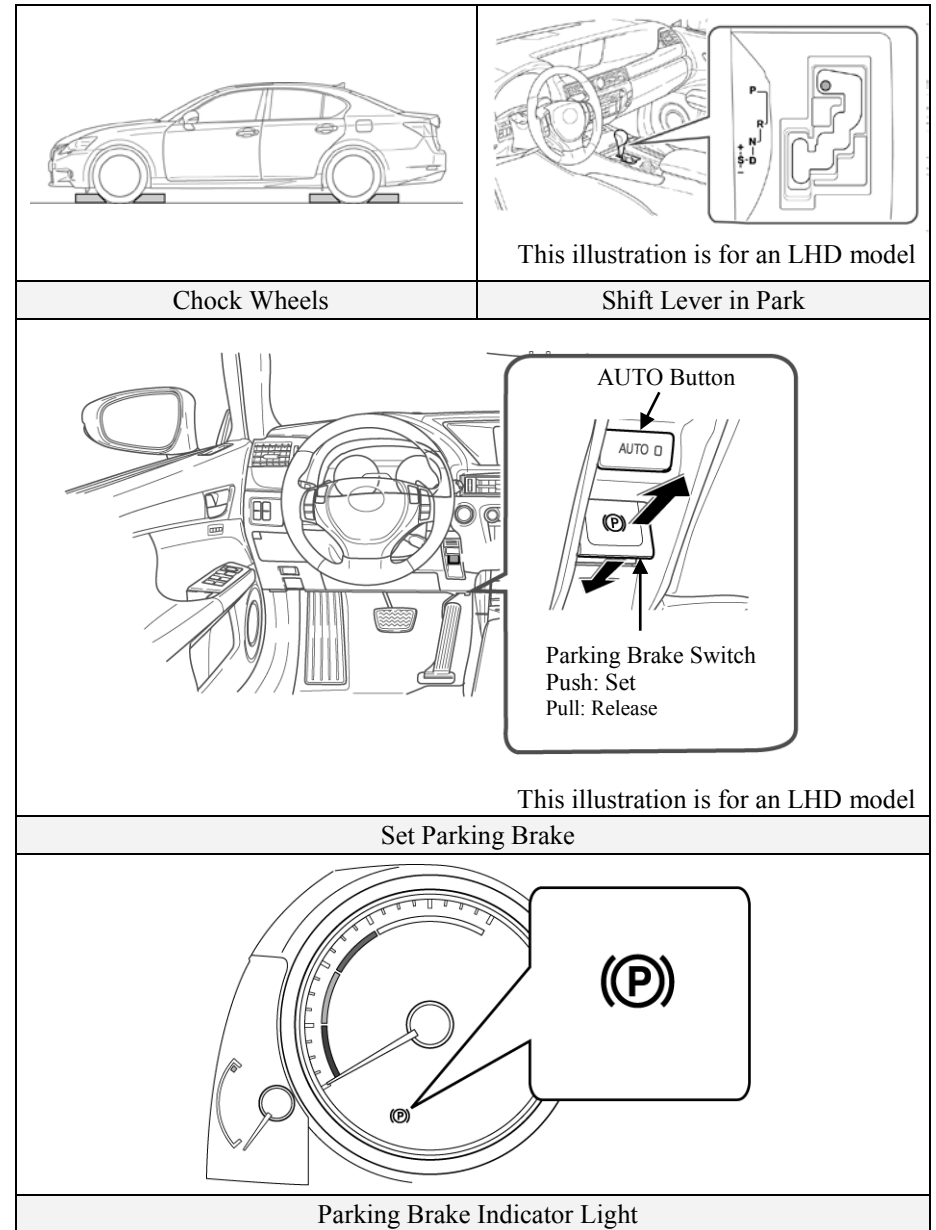

Emergency Response (Continued)

Extrication (Continued)

Procedure #1

1. Confirm the status of the **READY** indicator in the instrument cluster.
2. If the **READY** indicator is illuminated, the vehicle is on and operational. Shut off the vehicle by pushing the power button once.
3. The vehicle is already shut off if the instrument cluster lights and the **READY** indicator are not illuminated. Do **not** push the power button because the vehicle may start.
4. If the key is easily accessible, keep it at least 16 feet (5 meters) away from the vehicle.
5. If the key cannot be found, disconnect the 12 Volt auxiliary battery in the trunk to prevent accidental restarting of the vehicle.

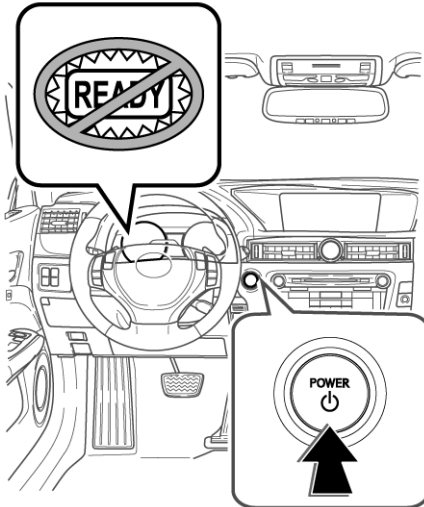
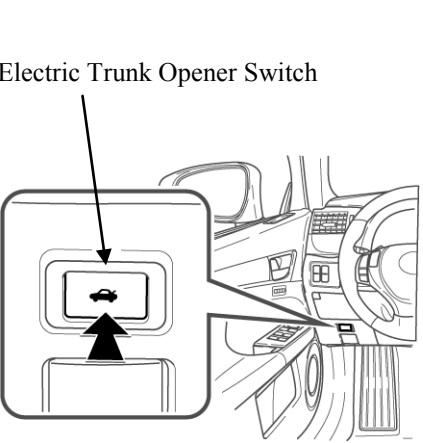
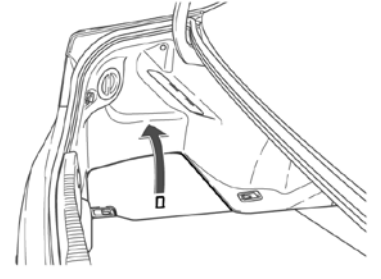
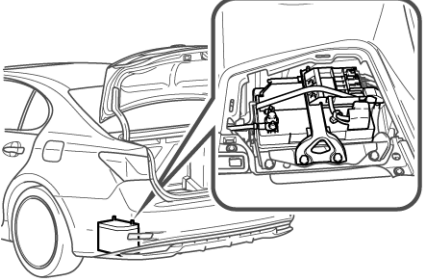
 <p>This illustration is for an LHD model</p>	<p>Electric Trunk Opener Switch</p>  <p>This illustration is for an LHD model</p>
<p>Shut Off Vehicle (READY-OFF)</p>	<p>Electric Trunk Opener Switch</p>
	
<p>Remove Luggage Compartment Side Trim Cover</p>	<p>12 Volt Auxiliary Battery Mounted in Trunk (Left Side)</p>

Emergency Response (Continued)

Extrication (Continued)

Procedure #2 (Alternate if power button is inaccessible)

1. Open the hood.
2. Remove the fuse box cover.
3. Remove the **IG2 MAIN** fuse (20 A yellow colored) in the engine compartment fuse box (refer to illustration). If the correct fuse cannot be recognized, pull all fuses in the fuse box.
4. Disconnect the 12 Volt auxiliary battery under the cover in the trunk.

NOTE:

Before disconnecting the 12 Volt auxiliary battery, if necessary, reposition the power tilt and telescopic steering wheel, power seats, lower the windows, unlock the doors, and open the fuel filler door as required. An electric fuel filler door opener switch is located on the lower dash panel to the left of the steering wheel. A manual fuel filler door release is located inside the left side trunk (refer to illustrations in the Roadside Assistance section on page 29). Once the 12 Volt auxiliary battery is disconnected, power controls will not operate.

WARNING:

- *The high voltage system may remain powered for up to 10 minutes after the vehicle is shut off or disabled. To prevent serious injury or death from severe burns or electric shock, avoid touching, cutting, or breaching any orange high voltage power cable or high voltage component.*
- *The SRS may remain powered for up to 90 seconds after the vehicle is shut off or disabled. To prevent serious injury or death from unintentional SRS deployment, avoid breaching the SRS components.*
- *If none of the disabling procedures can be performed, proceed with caution as there is no assurance that the high voltage electrical system, SRS, or fuel pump are disabled.*

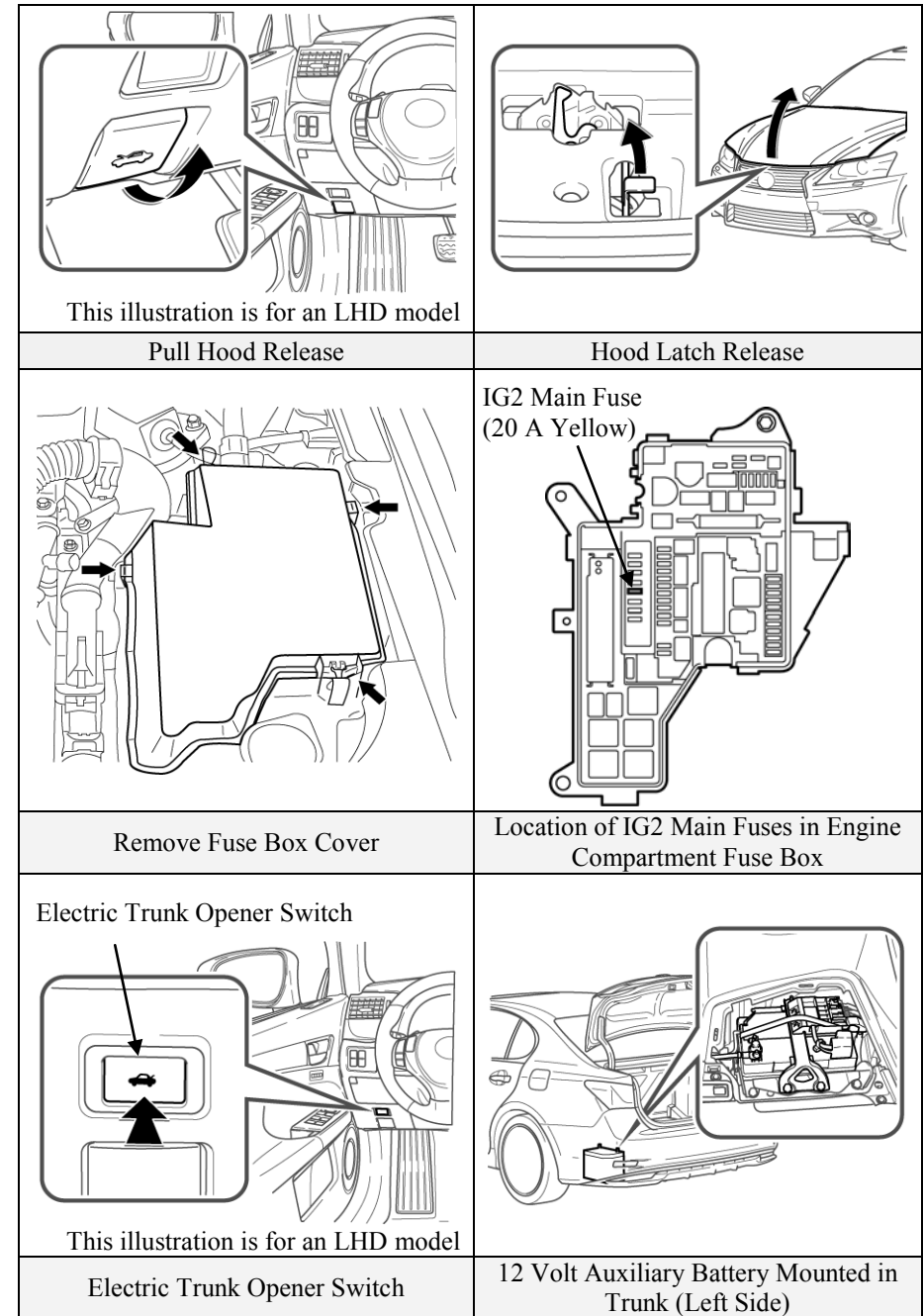

Emergency Response (Continued)

Extrication (Continued)

- Stabilize Vehicle

Crib at (4) points directly under the front and rear pillars.
Do not place cribbing under the high voltage power cables, exhaust system, or fuel system.

NOTE:

The GS450h is equipped with a tire pressure warning system that by design prevents pulling the metal valve stem with integral transmitter from the wheel. Snapping the valve stem with pliers or removing the valve cap and Schrader valve will release the air in the tire.

- Access Patients

Glass Removal

Use normal glass removal procedures as required.

SRS Awareness

Responders need to be cautious when working in close proximity to undeployed airbags and seat belt pretensioners. Frontal dual stage airbags automatically ignite both stages within a fraction of a second.

Door Removal/Displacement

Doors can be removed by conventional rescue tools such as hand, electric, and hydraulic tools. In certain situations, it may be easier to pry back the vehicle body to expose and unbolt the hinges.

NOTE:

To prevent accidental airbag deployment when performing front door removal/displacement, ensure the vehicle is shut off and the 12 Volt auxiliary battery is disconnected.

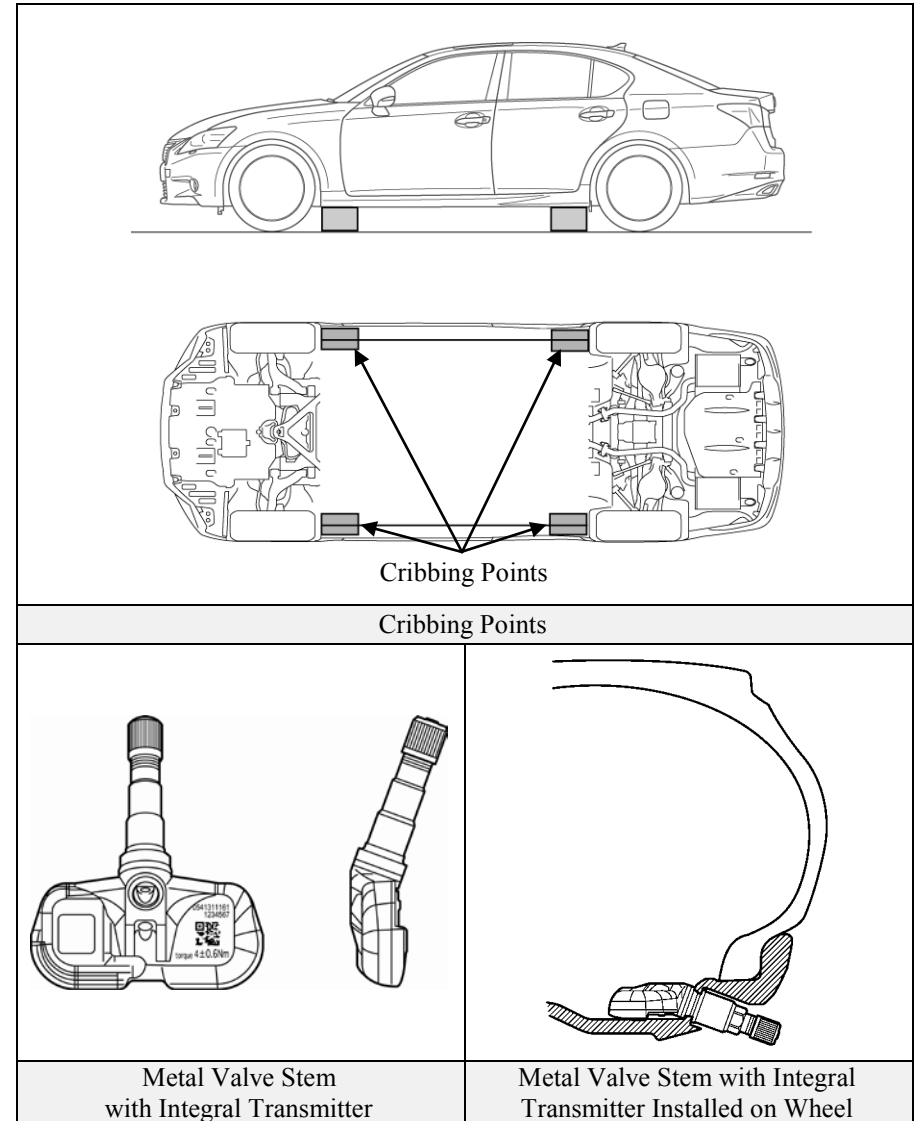

Emergency Response (Continued)

Extrication (Continued)

Roof Removal

The GS450h is equipped with side curtain airbags. When undeployed, total roof removal is not recommended. Patient access through the roof can be performed by cutting the roof center section inboard of the roof rails as illustrated. This would avoid breaching the side curtain airbags, inflators, and wiring harness.

NOTE:

The side curtain airbags may be identified as illustrated on this page (additional component details on page 16).

Dash Displacement

The GS450h is equipped with side curtain airbags. When undeployed, total roof removal is not recommended to avoid breaching the side curtain airbags, inflators, and wiring harness. As an alternative, dash displacement may be performed by using a Modified Dash Roll.

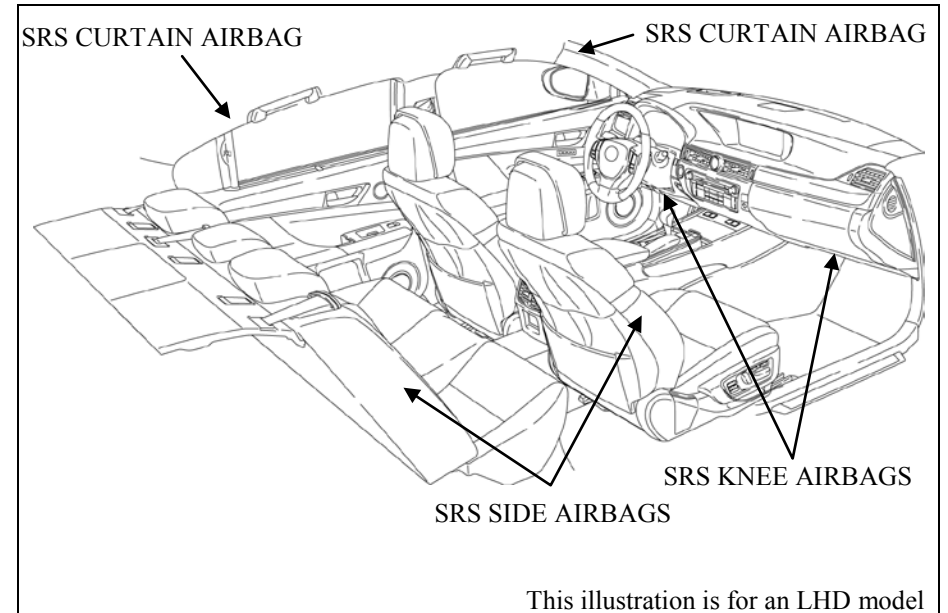

Seat Side, Side Curtain, and Knee Airbag Identifiers

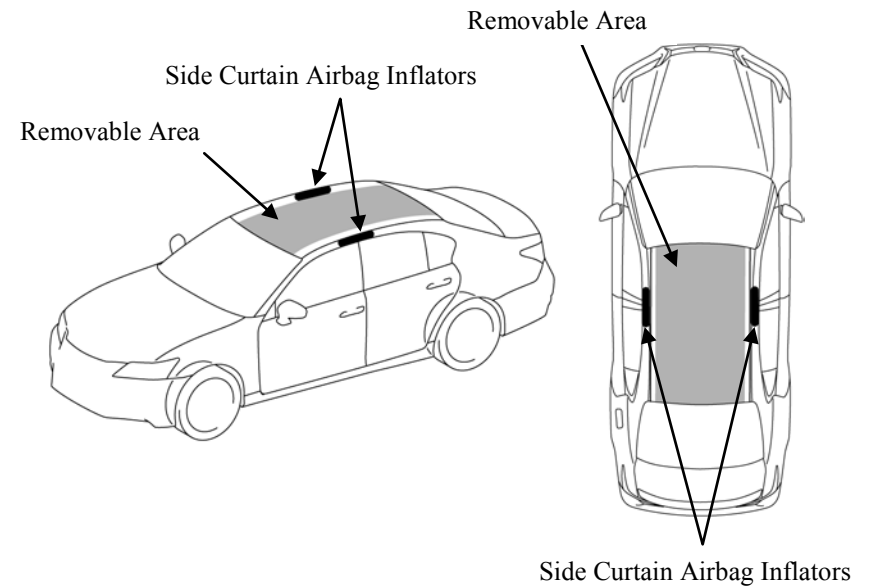

Roof Removal Area

Emergency Response (Continued)

Extrication (Continued)

Rescue Lift Air Bags

Responders should not place cribbing or rescue lift air bags under the high voltage power cables, exhaust system, or fuel system.

Repositioning Steering Wheel and Front Seats

Power tilt and telescopic steering wheel and seat controls are shown in the illustrations.

NOTE:

The GS450h has an electrochromic auto dimming rear view mirror. The mirror contains a minimal amount of transparent gel sealed between two glass plates that will not normally leak.

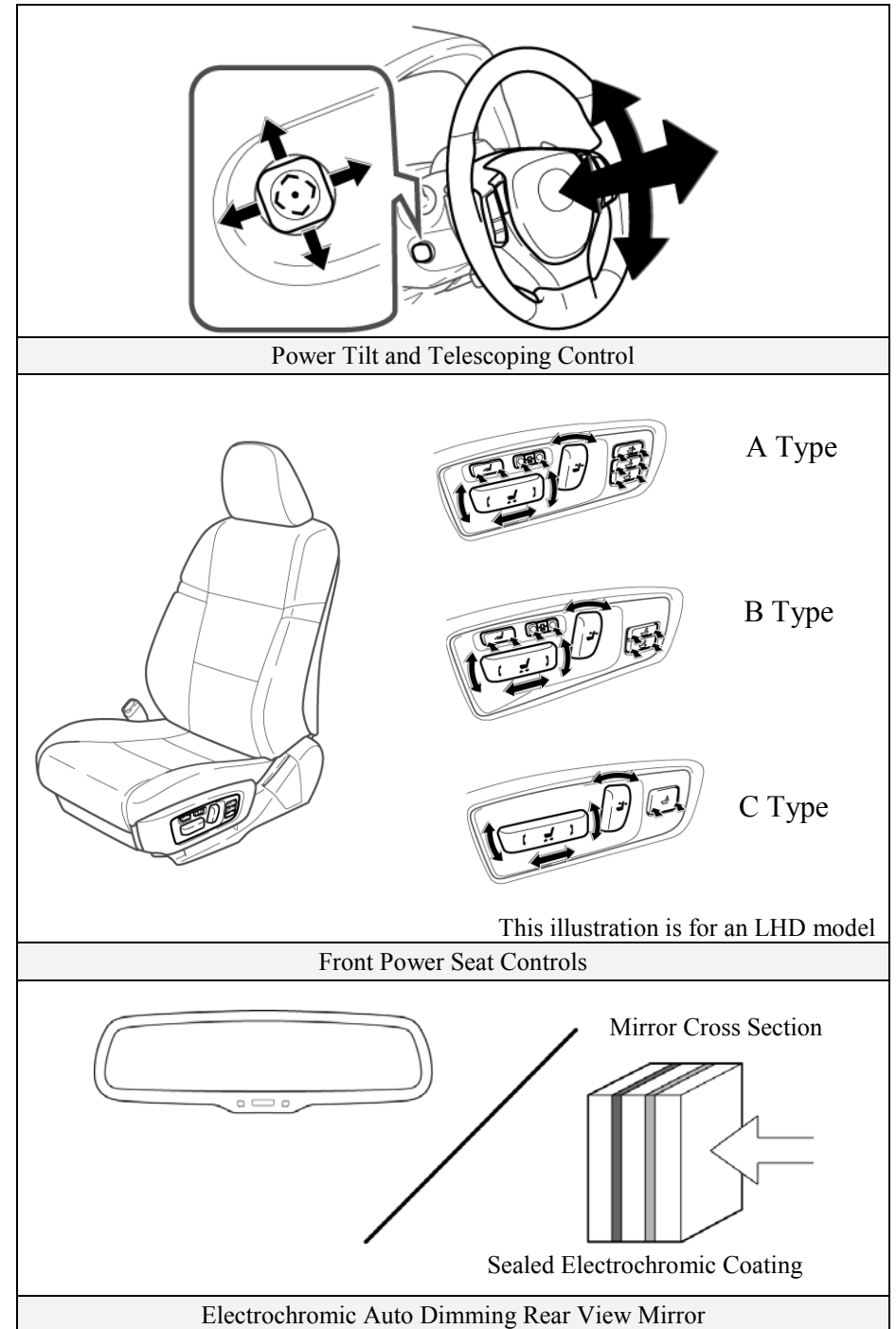

Emergency Response (Continued)

Fire

Approach and extinguish a fire using proper vehicle fire fighting practices as recommended by NFPA, IFSTA, or the National Fire Academy (USA).

- Extinguishing Agent
Water has been proven to be a suitable extinguishing agent.
- Initial Fire Attack
Perform a fast, aggressive fire attack.
Divert the runoff from entering watershed areas.
Attack teams may not be able to identify a GS450h until the fire has been knocked down and overhaul operations have commenced.
- Fire in the HV Battery Pack
Should a fire occur in the NiMH HV battery pack, attack crews should utilize a water stream or fog pattern to extinguish any fire within the vehicle *except* for the HV battery pack.

WARNING:

- *The NiMH battery electrolyte is a caustic alkaline (pH 13.5) that is damaging to human tissues. To avoid injury by coming in contact with the electrolyte, wear proper personal protective equipment.*
- *The battery modules are contained within a metal case and accessibility is limited.*
- *To avoid serious injury or death from severe burns or electric shock, **never** breach or remove the high voltage battery pack cover under any circumstance including fire.*

When allowed to burn themselves out, the GS450h NiMH battery modules burn rapidly and can quickly be reduced to ashes except for the metal.

Offensive Fire Attack

Normally, flooding a NiMH HV battery pack with copious amounts of water at a safe distance will effectively control the HV battery pack fire by cooling the adjacent NiMH battery modules to a point below their ignition temperature. The remaining modules on fire, if not extinguished by the water, will burn themselves out.

However, flooding the GS450h HV battery pack is *not* recommended due to the battery case design and location preventing the responder from properly applying water through the available vent openings safely. Therefore, it is recommended that the incident commander allow the GS450h HV battery pack to burn itself out.

Defensive Fire Attack

If the decision has been made to fight the fire using a defensive attack, the fire attack crew should pull back a safe distance and allow the NiMH battery modules to burn themselves out. During this defensive operation, fire crews may utilize a water stream or fog pattern to protect exposures or to control the path of smoke.

Emergency Response (Continued)

Overhaul

During overhaul, immobilize and disable the vehicle if not already done. Refer to illustrations on page 18, 19 and 20. The HV battery cover should **never** be breached or removed under any circumstances including fire. Doing so may result in severe electrical burns, shock, or electrocution.

- Immobilize Vehicle

Chock wheels and set the parking brake.
Move the shift lever to the **Park** position.

NOTE:

The GS450h utilizes a push/pull parking brake switch that electromechanically sets/releases the rear parking brakes.

- To set/release, push/pull the parking brake switch located on the dash to the right side of steering column (refer to illustration on page 18).
- If the AUTO button is set and illuminated, the parking brake will automatically set when the vehicle is shifted to the **Park** position.
- To verify that the parking brake is set, confirm that the parking brake indicator light illuminates on the instrument cluster (refer to illustration on page 18).
The parking brake indicator light will turn off after approximately 15 seconds.

- Disable Vehicle

Performing either of the following two procedures will shut the vehicle off and disable the HV battery pack, SRS, and gasoline fuel pump.

Procedure #1

1. Confirm the status of the **READY** indicator in the instrument cluster.
2. If the **READY** indicator is illuminated, the vehicle is on and operational. Shut off the vehicle by pushing the power button once.
3. The vehicle is already shut off if the instrument cluster lights and the **READY** indicator are not illuminated. Do **not** push the power button because the vehicle may start.

4. If the key is easily accessible, keep it at least 16 feet (5 meters) away from the vehicle.
5. If the key cannot be found, disconnect the 12 Volt auxiliary battery in the trunk to prevent accidental restarting of the vehicle.

Procedure #2 (Alternate if power button is inaccessible)

1. Open the hood and remove the fuse box cover.
2. Remove the **IG2 MAIN** fuse (20 A yellow colored) in the engine compartment fuse box as illustrated on page 20. If the correct fuse cannot be recognized, pull all fuses in the fuse box.
3. Disconnect the 12 Volt auxiliary battery in the trunk.

NOTE:

Before disconnecting the 12 Volt auxiliary battery, if necessary, reposition the power tilt and telescopic steering wheel, power seats, lower the windows, unlock the doors, and open the fuel filler door as required. The lock of the fuel filler door is linked with the door lock. A manual fuel filler door release is located inside the left side trunk (refer to illustrations in the Roadside Assistance section on page 29). Once the 12 Volt auxiliary battery is disconnected, power controls will not operate.

WARNING:

- *The high voltage system may remain powered for up to 10 minutes after the vehicle is shut off or disabled. To prevent serious injury or death from severe burns or electric shock, avoid touching, cutting, or breaching any orange high voltage power cable or high voltage component.*
- *The SRS may remain powered for up to 90 seconds after the vehicle is shut off or disabled. To prevent serious injury or death from unintentional SRS deployment, avoid breaching the SRS components.*
- *If none of the disabling procedures can be performed, proceed with caution as there is no assurance that the high voltage electrical system, SRS, or fuel pump are disabled.*

Emergency Response (Continued)

Recovering/Recycling of NiMH HV Battery Pack

Clean up of the HV battery pack can be accomplished by the vehicle recovery crew without further concern of runoff or spillage. For information regarding recycling of the HV battery pack, contact the nearest Lexus dealer.

Spills

The GS450h contains the same common automotive fluids used in other non-hybrid Lexus vehicles, with the exception of the NiMH electrolyte used in the HV battery pack. The NiMH battery electrolyte is a caustic alkaline (pH 13.5) that is damaging to human tissues. The electrolyte, however, is absorbed in the cell plates and will not normally spill or leak out even if a battery module is cracked. A catastrophic crash that would breach both the metal battery pack case and a metal battery module would be a rare occurrence.

Similar to the use of baking soda to neutralize a lead-acid battery electrolyte spill, a dilute boric acid solution or vinegar can be used to neutralize a NiMH battery electrolyte spill.

NOTE:

Electrolyte leakage from the HV battery pack is unlikely due to its construction and the amount of available electrolyte contained within the NiMH modules. Any spillage would not warrant a declaration as a hazardous material incident. Responders should follow the recommendations as outlined in this emergency response guide.

In an emergency, the NiMH battery part number G9280-30090 manufacturer's Product Safety Data Sheet (PSDS).

- Handle NiMH electrolyte spills using the following Personal Protective Equipment (PPE):
 - Splash shield or safety goggles. Fold down helmet shields are not acceptable for acid or electrolyte spills.
 - Rubber, latex or nitrile gloves.
 - Apron suitable for alkaline.
 - Rubber boots.
- Neutralize NiMH Electrolyte
 - Use a boric acid solution or vinegar.
 - Boric acid solution - 800 grams boric acid to 20 liters water or 5.5 ounces boric acid to 1 gallon of water.

First Aid

Emergency responders may not be familiar with a NiMH electrolyte exposure when rendering aid to a patient. Exposure to the electrolyte is unlikely except in a catastrophic crash or through improper handling. Utilize the following guidelines in the event of exposure.



WARNING:

The NiMH battery electrolyte is a caustic alkaline (pH 13.5) that is damaging to human tissues. To avoid injury by coming in contact with the electrolyte, wear proper personal protective equipment.

- Wear Personal Protective Equipment (PPE)
 - Splash shield or safety goggles. Fold down helmet shields are not acceptable for acid or electrolyte spills.
 - Rubber, latex or nitrile gloves.
 - Apron suitable for alkaline.
 - Rubber boots.
- Absorption
 - Perform gross decontamination by removing affected clothing and properly disposing of the garments.
 - Rinse the affected areas with water for 20 minutes.
 - Transport patients to the nearest emergency medical care facility.
- Inhalation in Non-Fire Situations
 - No toxic gases are emitted under normal conditions.

Emergency Response (Continued)

First Aid (Continued)

- **Inhalation in Fire Situations**
Toxic gases are given off as by-products of combustion. All responders in the Hot Zone should wear the proper PPE for fire fighting including SCBA.
Move a patient from the hazardous environment to a safe area and administer oxygen.
Transport patients to the nearest emergency medical care facility.
- **Ingestion**
Do not induce vomiting.
Allow the patient to drink large quantities of water to dilute the electrolyte (never give water to an unconscious person).
If vomiting occurs spontaneously, keep the patient's head lowered and forward to reduce the risk of aspiration.
Transport patients to the nearest emergency medical care facility.

Submersion

A submerged hybrid vehicle does not have high voltage potential on the metal vehicle body, and is safe to touch.

Access Patients

Responders can access the patient and perform normal extrication procedures. High voltage orange color coded power cables and high voltage components should never be touched, cut, or breached.

Vehicle Recovery

If a hybrid vehicle is fully or partially submerged in water, emergency responders may not be able to determine if the vehicle has been automatically disabled. The GS450h may be handled by following these recommendations:

1. Remove the vehicle from the water.
2. Drain the water from the vehicle if possible.
3. Follow the immobilizing and disabling procedures on page 18, 19 and 20.

Roadside Assistance

Roadside assistance for the Lexus GS450h may be handled like conventional Lexus vehicles except as noted in the following pages.

Shift Lever

Similar to many Lexus vehicles, the GS450h uses a gated shift lever as shown in the illustration. However, the GS450h shift lever includes an **S** position for 6 levels of engine braking.

Towing

The GS450h is a rear wheel drive vehicle and it **must** be towed with the rear wheels off the ground. Failure to do so may cause serious damage to Lexus Hybrid Drive components.

- A flat bed trailer is the preferred method of towing.
- When towing the vehicle with the front wheels on the ground, be sure to release the steering lock by turning the accessory mode.
- The vehicle may be shifted out of **Park** into **Neutral** by turning the ignition-on, depressing the brake, then moving the gated shift lever to **N**.
- If the shift lever cannot be moved out of **Park**, a shift lock release button is provided under the cover near the shift lever as shown in the illustration.
- If a tow truck is not available, in an emergency the vehicle may be temporarily towed using a cable or chain secured to the emergency towing eyelet or rear hooks. This should only be attempted on hard, paved roads for short distance at low speeds (below 18 mph (30km/h)). The eyelet is located with the tools in the trunk, refer to the illustration on page 30.

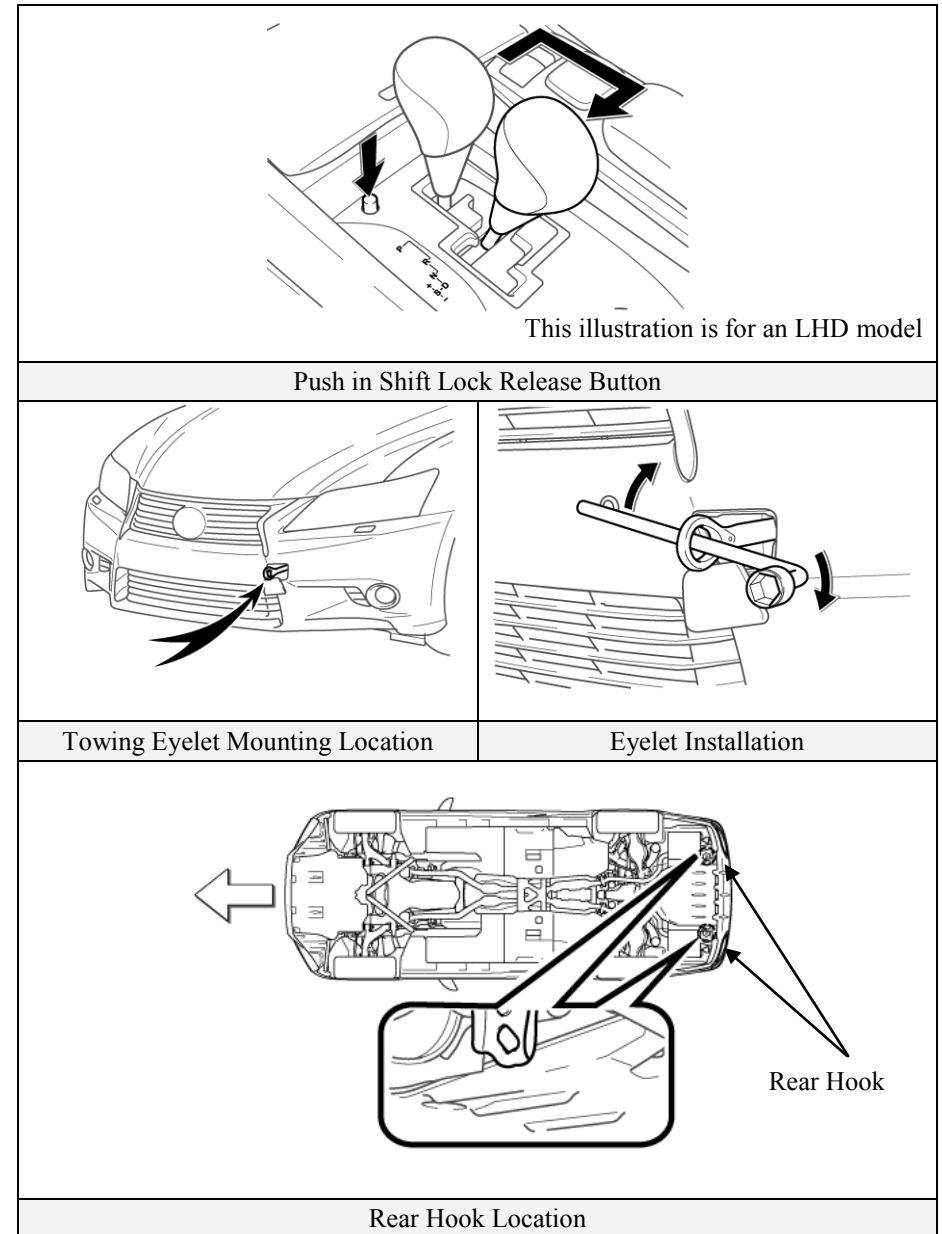

Roadside Assistance (Continued)

Electric Trunk Opener

The GS450h is equipped with an electric trunk opener. In the event of 12 Volt power loss, the trunk can be opened with the metal cut key hidden in the key.

Fuel filler door Opening

The lock of the fuel filler door is linked with the door lock. When the doors are unlocked, the fuel filler door can be opened by pressing it. In the event of 12 Volt power loss, a manual release is located inside the trunk as shown in the illustration.

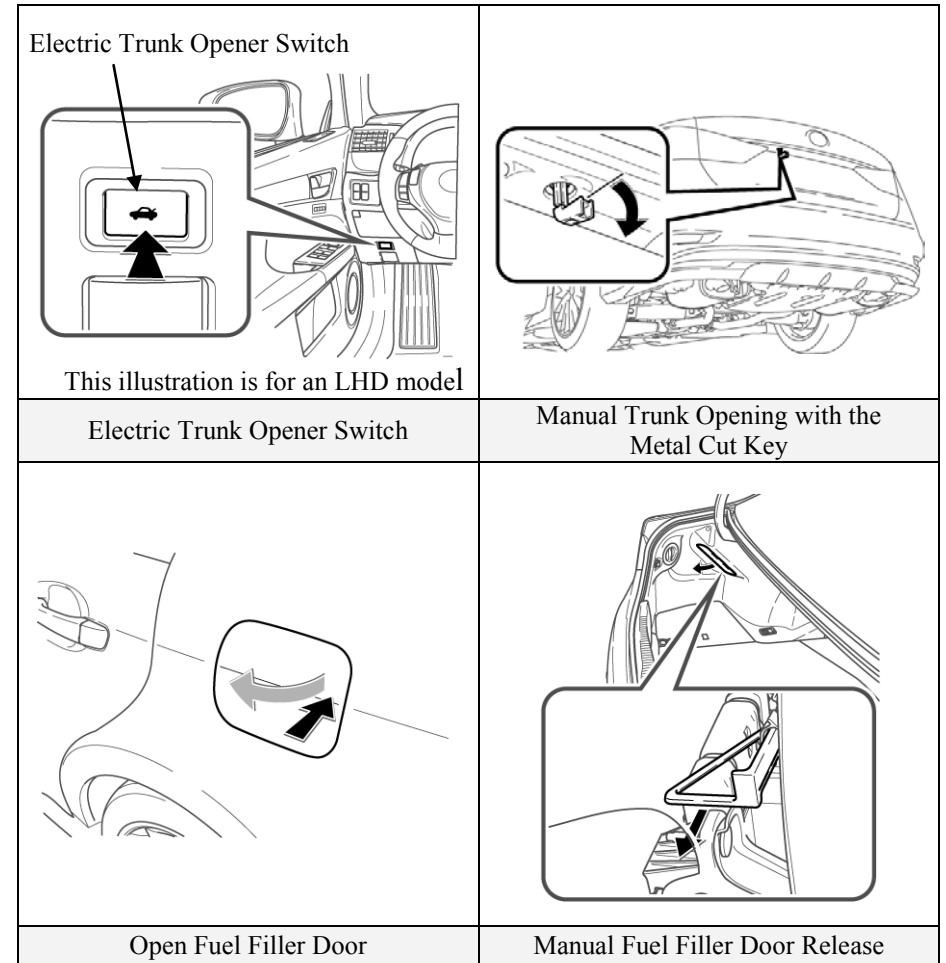

Roadside Assistance (Continued)

Spare Tire (with Spare Tire Model)

The tools, jack, towing eyelet, and spare tire are provided as shown.

Emergency Tire Puncture Repair Kit (without Spare Tire Model)

The tools, jack, towing eyelet, and emergency tire puncture repair kit are provided as shown.

Electric Parking Brake

The GS450h is equipped with an electric parking brake set/release switch. In the event of a 12 Volt power loss, the parking brake cannot be electrically operated. The parking brake can be manually released using the on-board tools.

- Remove the spare tire from inside trunk.(with spare tire model)
- Remove the luggage compartment trim box and spare wheel cover tray from inside trunk. (without spare tire model)Remove the plug as illustrated.
- Replace the tool as illustrated.
- Insert the vehicle tool in the hole. While pressing firmly on the tool, turn it counterclockwise until the parking brake is released.

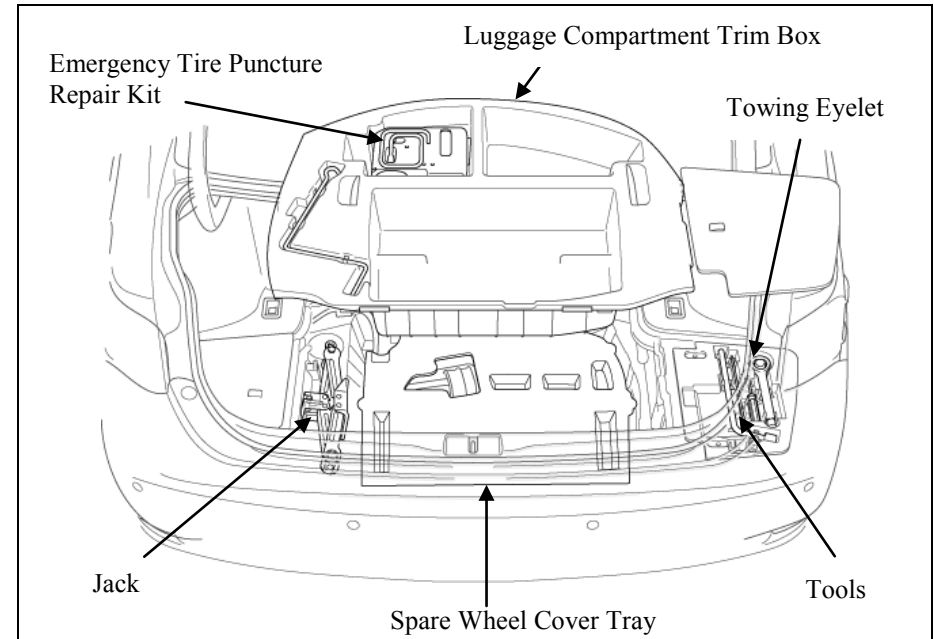

Tools, Jack, Towing Eyelet, Emergency Tire Puncture Repair Kit, Luggage Compartment Trim Box, and Spare Wheel Cover Tray in the Trunk (without Spare Tire Model)

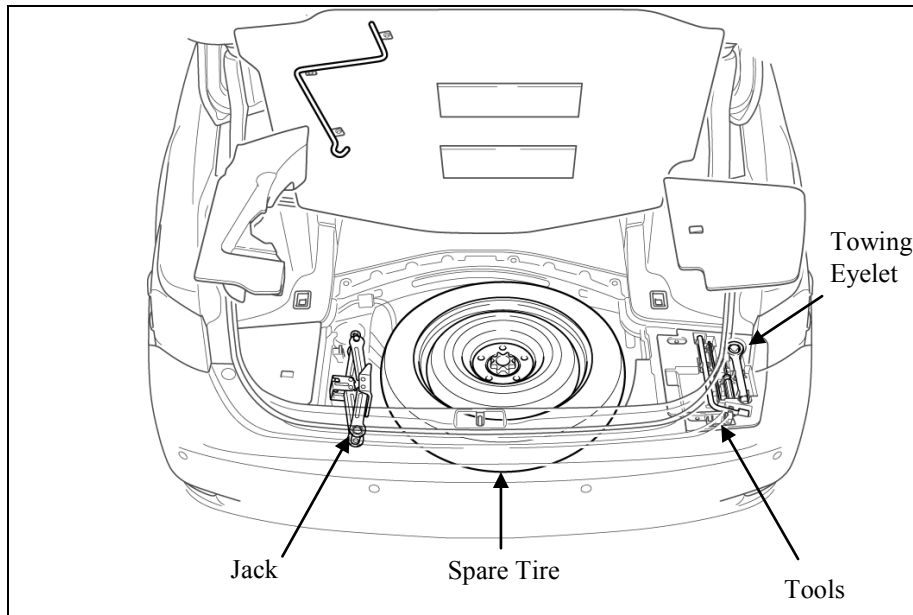

Tools, Jack, Towing Eyelet, and Spare Tire in the Trunk (with Spare Tire Model)

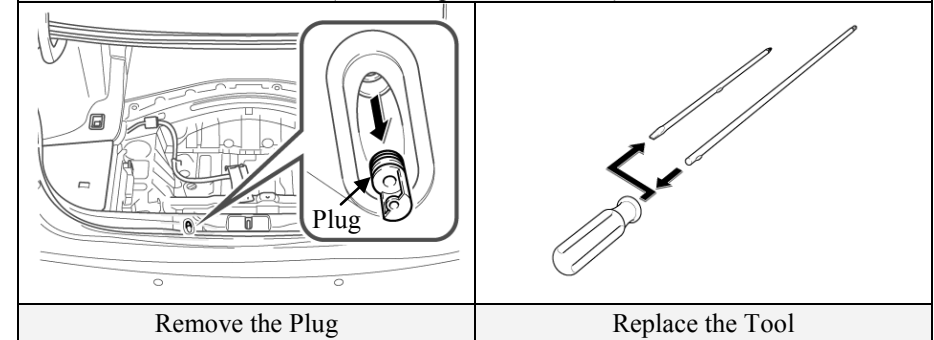

Remove the Plug

Replace the Tool

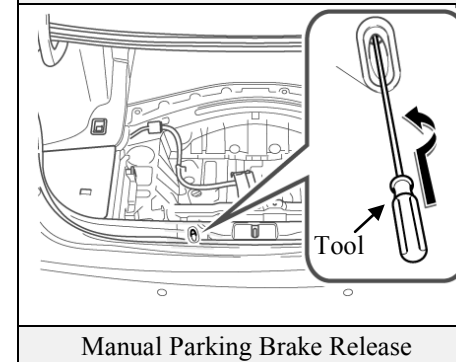

Manual Parking Brake Release

Roadside Assistance (Continued)

Jump Starting

The 12 Volt auxiliary battery may be jump started if the vehicle does not start and the instrument cluster gauges are dim or off after depressing the brake pedal and pushing the power button.

The 12 Volt auxiliary battery is located in the trunk. The trunk opener will not operate if the auxiliary battery is discharged. Instead use the metal cut key hidden in the key to open the trunk.

- Open the trunk and remove the luggage compartment side trim cover on the left side.
- Connect the positive jumper cable to the positive terminal following the numbered sequence.
- Connect the negative jumper cable to the negative terminal following the numbered sequence.
- Place the key in proximity to the interior of the vehicle, depress the brake pedal and push the power button.

NOTE:

If the vehicle does not recognize the key after connecting the booster battery to the vehicle, open and close the driver door when the vehicle is shut off.

If the key internal battery is dead, touch the Lexus emblem side of the key to the power button during the start sequence. See the instructions and illustrations on page 10 for more details.

- The high voltage HV battery pack cannot be jump started.

Immobilizer & Anti-Theft Alarm

The GS450h is equipped with a standard immobilizer system and an optional anti-theft alarm.

- The vehicle can be started only with a registered key.

- To disarm the anti-theft alarm, unlock the door by using the key button, hidden metal cut key, or door handle touch sensor. Turning the ignition-on or starting the vehicle will also disarm the anti-theft alarm.

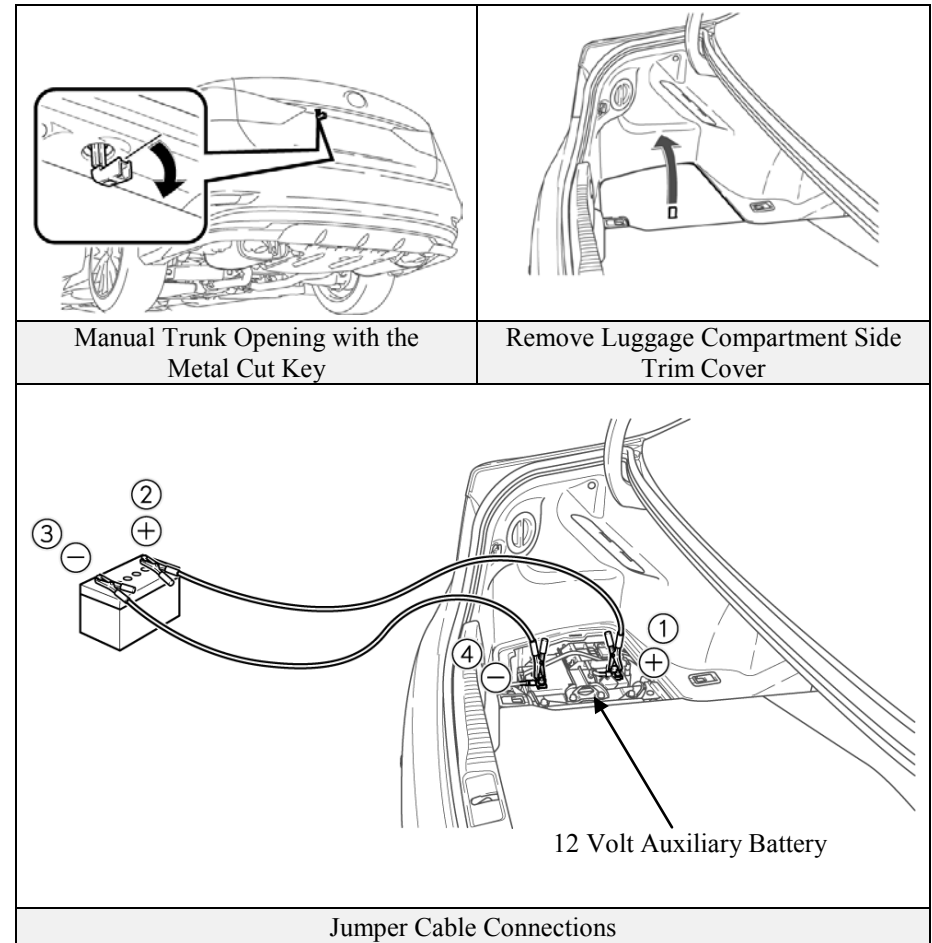

Product Safety Data Sheet

This product (a battery) is an "Article" pursuant to 29 CFR 1910.1200 and, as such, is not subject to the OSHA Hazard Communication Standard requirements for preparation of a Material Safety Data Sheets, (MSDS).
 This Product Safety Data Sheet is prepared only to provide information to our customers.

1. PRODUCT AND COMPANY IDENTIFICATION

1.1	Product name	Nickel Metal Hydride Battery (Module)
1.2	Applicable models	EV-MH type EV-MP095R15A (EV-95) EV-MP6R5R01 (GEN I) EV-MP6R5R02 (GEN II) EV-MP6R5R03 (GEN 2.5 8cells module type) EV-MP6R5R27 (GEN 2.5 12cells module type) EV-MP6R5R47 (GEN 2.5L 12cells module type)
1.3	Product use	Hybrid Vehicle Battery
1.4	Name of manufacturer	Primearth EV Energy Co., Ltd.
1.5	Address of manufacturer	20,Okasaki,Kosai-City,Shizuoka, 431-0422 Japan
1.6	Phone number of manufacturer	+81-53-577-3592 (Japan)
1.7	Post in charge	Enginnering Dept.
1.8	Name of person in charge	Osamu Takahashi
1.9	Issue number	P0262

2. HAZARD IDENTIFICATION

This product is not dangerous as long as it is used for prescribed purposes and in accordance with its designated usage. As the product is a storage device for electricity, it may give the user an electric shock. It has no adverse effect on human health or the environment unless the pack and cell casings are breached.

2.1	Physical and chemical hazard	This product does not constitute a physical and chemical hazard as long as it is used for prescribed purposes and in accordance with its designated usage. The alkaline electrolyte or materials in the battery may be dangerous if they leak out of the casing due to dismantling or breaching of the battery. This product may cause electric shock, fire, or injury if it is used for purposes other than those prescribed or without following the designated usage.
2.2	Hazard to human health	This product is not hazardous to human health in normal use. However, if the product dismantle or is breached, the alkaline electrolyte or materials that may leak out of the outer casing may adversely affect human health. This product contains both nickel compounds and cobalt, which are classified as carcinogens by IARC and NTP.
2.3	Hazard to environment	This product is not hazardous to the environment as long as it is used for prescribed purposes and in accordance with its designated usage. However, the contents of the product may have an adverse effect on the environment in the event of their leakage from the casing due to dismantling or

3. COMPOSITION & INGREDIENT INFORMATION

Chemical name	Chemical symbol	CAS. No.	Exposure limits in air	
			ACGIH	OSHA
Positive electrode, composed of:				
•Nickel hydroxide	Ni(OH)2	12054-48-7	0.2mg/m3	1mg/m3
•Nickel	Ni	7440-02-0	0.2mg/m3	1mg/m3
•Cobalt	Co	7440-48-4	0.02mg/m3	0.1mg/m3
Negative electrode, composed of:				
•Hydrogen absorbing alloy	*1			
•Iron	Fe	7439-89-6	NA	NA
Alkaline electrolyte	*2			

*1: Main contents contained in hydrogen absorbing alloy
 Nickel(Ni)-CAS#7440-02-0, Cobalt(Co)-CAS#7440-48-4, Manganese (Mn)-CAS#7439-96-5,
 Aluminum (Al)-CAS#7429-90-5, Rare earths [Lanthanum (La)-CAS#7439-91-0, Cerium (Ce)-CAS#7440-45-1,
 Neodymium (Nd)-CAS#7440-00-8, Praseodymium (Pr)-CAS#7440-10-0]

*2: Main contents contained in alkaline electrolyte
 Potassium hydroxide (KOH)-CAS#1310-58-3, Sodium hydroxide (NaOH)-CAS#1310-73-2,
 Lithium hydroxide (LiOH)-CAS#1310-65-2

4. FIRST AID MEASURES

In the event of the leakage of electrolyte or gassing of the battery, take the appropriate first aid measures from the following.

4.1	Eye contact	Contact may cause corneal injury and blindness. Wash eyes with large amounts of running water for at least 15 minutes. Seek medical treatment immediately. If appropriate actions are not taken, eye disorders may result.
4.2	Skin contact	Wash the contact area with plenty of water. Seek medical treatment immediately. Clothing, shoes, and socks, etc. which have come into contact with alkaline electrolyte should be taken off immediately. If appropriate actions are not taken, skin inflammation may occur.
4.3	Inhalation	Move the exposed person to fresh air area immediately. Cover up the affected person with a blanket. Seek medical treatment immediately.
4.4	Ingestion	Do not induce vomiting . Seek medical treatment immediately.

5. FIREFIGHTING MEASURES

In the event of a battery fire, take the following measures.

5.1	Extinguishing media and method	(1) Use a dry powder acrylonitrile butadiene styrene (ABS) fire extinguisher for fire-fighting. (2)Extinguishing a fire with a large amount of water may be an effective method . However, this should be considered as a supplementary means If there are no readily available large amounts of water, use dry sand instead; as the application of only a small amount of water may temporarily act as an accelerant and affect the fire adversely while the hydrogen storage alloy is burning.
5.2	Exposure controls and personal protection for fire-fighting	Use air-breathing apparatus as noxious fumes may be produced.
5.3	Fire spread prevention	(1) In the case of fire, remove surrounding inflammables immediately. (2) In the case of fire in peripheral devices, move the battery to a safe place immediately.

6. ACCIDENTAL RELEASE MEASURES

Take the following measures if the alkaline electrolyte has leaked out of the battery.

6.1		Wipe up the alkaline electrolyte with a cloth. Dispose of the cloth used to wipe up the electrolyte in accordance with applicable laws and regulations.
-----	--	---

7. HANDLING & STORAGE INFORMATION

Observe the following cautions and prohibited items. Handle the battery carefully.

7.1	Prohibited items	(1) Short-circuiting Short-circuiting may cause burn injury due to ignition or heating effect. (2) Dismantle or modification Alkaline electrolyte leaks when the battery (cell) is disassembled. (3) Overcharging or over-discharging Oxygen or hydrogen may be produced when the battery is overcharged or over-discharged. (4) Use in an airtight container The container may explode due to the gas produced from the battery.
-----	------------------	--

7.2	Cautions	(1) Do not stack a battery on another battery. (2) Do not store batteries on electrically conductive surfaces such as metals. (3) Wear protective glasses and rubber gloves while handling batteries.
8. EXPOSURE CONTROLS & PERSONAL PROTECTION		
Take the following measures in the event of leakage of the alkaline electrolyte or alkaline mixed gas from the battery.		
8.1	Facilities	(1) Store the product in a depository with local exhaust systems for ventilation. (2) Install an exhaust system or exhaust port when the product is used in a container.
8.2	Protective equipment	Wear protective glasses, protective gloves, and simple filter mask.
9. PHYSICAL & CHEMICAL PROPERTIES		
9.1	Physical state	Solid
9.2	Order	No order
9.3	pH	Not applicable (ELECTROLYTE : >12)
9.4	Freezing point	Not applicable
9.5	Boiling point	Not applicable (ELECTROLYTE : 100°C; Water)
9.6	Evaporation rate	Not applicable
9.7	Vapor pressure	Not applicable
9.8	Vapor density	Not applicable
9.9	Solubility (Water)	Not applicable (Electrolyte is soluble.)
10. STABILITY & REACTIVITY		
This product is stable as long as it is used for prescribed purposes and in accordance with its designated usage. However, short-circuiting, overcharging/over-discharging, and long-term storage in a high-temperature environment may lead to the ignition or explosion of the battery.		
10.1	Possible causes of fire	Sparks due to short-circuit. A large current is applied to a module or a cell.
10.2	Possible causes of explosion	The battery will not explode by itself unless the safety valve is frequently activated and the battery is kept in an airtight container, in which case the oxygen and hydrogen produced from the battery may trigger an explosion.
10.3	Possible causes of fire and explosion	(1) Overcharging or over-discharging (2) The temperature of the battery at 100°C or higher (3) Overcharging or over-discharging of the battery in an airtight container located close to a heat source
11. TOXICOLOGICAL INFORMATION		
This product is not hazardous as long as it is used for prescribed purposes and in accordance with its designated usage. If the battery disintegrates or is breached, the alkaline electrolyte or contents that have leaked out of the casing may adversely affect human health.		
11.1	Carcinogenicity	The nickel-plated iron of this product is not harmful as long as it is used for prescribed purposes and in accordance with its designated usage. This product contains both nickel compounds and cobalt, which are classified as carcinogens by the International Agency for Research on Cancer (IARC) and the National Toxicology Program (NTP).
12. ECOLOGICAL INFORMATION		
12.1		This product is not dangerous as long as it is used for prescribed purposes and in accordance with its designated usage. This product is not hazardous to the environment as long as it is used for prescribed purposes and in accordance with its designated usage. However, the contents of the product may have an adverse effect on the environment in the event of their leakage from the casing due to dismantling or breaching of the battery.
13. DISPOSAL CONSIDERATIONS		
13.1		Batteries should be disposed in accordance with designated provisions by vehicle manufacturers or dealers.

14. NOTES IN TRANSPORTATION		
Refer to "15. REGULATORY INFORMATION" for applicable laws and regulations.		
14.1	Label of contents	The indication of surface of the casing are not subjected any regulations. Refer to "14. REGULATORY INFORMATION" for applicable laws and regulations.
14.2	No short-circuit	The battery terminals should be designed so that external short-circuiting can be avoided. Make sure the batteries are not short-circuited during the packaging process.
14.3	No damage and overturn	Use sufficiently strong materials for packaging boxes so that the product is not damaged due to vibration, shocks, falls, stacking, and so on. Pack the product so that the battery does not fall sideways, and is not inverted during transportation.
14.4	Protection from rain water	Avoid contact with rain or other water during storage and transportation.
14.5	Protection from fire and high temperatures	Do not place the product close to fire during storage and transportation. Avoid storage in a high-temperature environment. Example: Avoid leaving batteries for disposal in a parked vehicle under the scorching sun. Take sufficient care to avoid prolonged exposure to high temperature.
15. REGULATORY INFORMATION		
15.1	Hazardous materials of transportation New Regulations: United Nations, IMDG-Code Enforcement on Jan. 1, 2012	(1) United Nations (Transport of Dangerous Goods) • UN Number 3496 Classes 9 • Special Provision 117 Subjected to these Regulations only when transport by sea.
		(2) International Air Transport Association (IATA) • Not Registered • Special Provision A123 This entry applies to Batteries, electric storage, not otherwise listed in Subsection 4.2 - List of Dangerous Goods. Examples of such batteries are: alkali-manganese, zinc-carbon, nickel-metal hydride and nickel-cadmium batteries. Any electrical battery or battery powered device, equipment or vehicle having the potential of a dangerous evolution of heat must be prepared for transport so as to prevent (a) a short-circuit (e.g. in the case of batteries, by the effective insulation of exposed terminals; or, in the case of equipment, by disconnection of the battery and protection of exposed terminals); and (b) accidental activation. The words "Not Restricted" and the Special Provision number must be included in the description of the substance on the Air Waybill as required by 8.2.6, when an Air Waybill is issued.
		(3) International Maritime Dangerous Goods Code (IMDG-Code) • UN Number 3496 Classes 9 • Special Provision 117 Only regulated when transported by sea. 963 Nickel-metal hydride button cells or nickel-metal hydride cells or batteries packed with or contained in equipment are not subjected to the provisions of this code. All other nickel-metal hydride cells or batteries shall be securely packed and protected from short circuit. They are subjected to other provisions of this Code provided that they are loaded in a cargo transport unit in a total quantity of less than 100 kg gross mass. When loaded in a cargo transport unit in a total quantity of 100 kg gross mass or more, they are not subjected to other provisions of this Code except those of 5.4.1, 5.4.3 and column (16) of the Dangerous Goods List in chapter 3.2.

		<p>(4) US DOT(Department of Transportation)Title 49 CFR Parts 100-185 Subpart B—Table of Hazardous Materials and Special Provisions § 172.101 Purpose and use of hazardous materials table. Hazardous materials descriptions and proper shipping names * Batteries, nickel-metal hydride see Batteries, dry, sealed, n.o.s. for nickel-metal hydride batteries transported by modes other than vessel * Batteries, dry, sealed, n.o.s.</p> <p>§ 172.102 Special provisions. * Transport by modes other than vessel : Special provision 130 * Transport by vessel : Special provision 340</p> <hr/> <p>(5) Japan MLIT (Ministry of Land, Infrastructure, Transport and Tourism) Bulletin 1530 Notice 272 (Dec.22,2010) •UN Number 3496 Classes 9 •Dangerous Goods List Coluum 6(5) SP963 1 Shall be securely packed and protected from short circuit. 2 Tag plate or the name of goods are not required to be displayed. •Dangerous Goods List Coluum 10 SP963 1 Nickel-metal hydride button cells or nickel-metal hydride cells or batteries packed with or contained in equipment are not subjected to the provisions of this notice. 2 All other nickel-metal hydride cells or batteries shall be securely packed and protected from short circuit. They are subjected to other provisions of this notice provided that they are loaded in a cargo transport unit in a total quantity of less than 100 kg gross mass.</p>
16. OTHER INFORMATION		
16.1	Cautions	<p>(1)Cautions and prohibited items in this Data Sheet relate to only normal use. Take appropriate safety measures suited for the environment when the product is used for special purposes. (2)This Data Sheet provides only the information of the product, and is not to be taken as a warranty. (3)It is intended for use by persons with technical skills and at their own discretion and risk. (4)The user is responsible for determining that any usage of the data or information in this Data Sheet is in accordance with associated federal, state, and local laws and regulations.</p>
16.2	Date of creation/revision	November 10, 2011