



CAMRY

Gasoline-Electric

Hybrid Synergy Drive

***HYBRID VEHICLE
DISMANTLING
MANUAL***



AVV50 Series

Foreword

This guide was developed to educate and assist dismantlers in the safe handling of Toyota Camry gasoline-electric hybrid vehicles. Camry hybrid dismantling procedures are similar to other non-hybrid Toyota vehicles with the exception of the high voltage electrical system. It is important to recognize and understand the high voltage electrical system features and specifications of the Toyota Camry hybrid, as they may not be familiar to dismantlers.

High voltage electricity powers the A/C compressor, electric motor, generator, and inverter/converter. All other conventional automotive electrical devices such as the headlights, radio, and gauges are powered from a separate 12 Volt auxiliary battery. Numerous safeguards have been designed into the Camry hybrid to help ensure the high voltage, approximately 244.8 Volt, Nickel Metal Hydride (NiMH) Hybrid Vehicle (HV) battery pack is kept safe and secure in an accident.

The NiMH HV battery pack contains sealed batteries that are similar to rechargeable batteries used in some battery operated power tools and other consumer products. The electrolyte is absorbed in the cell plates and will not normally leak out even if the battery is cracked. In the unlikely event the electrolyte does leak, it can be easily neutralized with a dilute boric acid solution or vinegar.

High voltage cables, identifiable by orange insulation and connectors, are isolated from the metal chassis of the vehicle.

Additional topics contained in the guide include:

- Toyota Camry hybrid identification.
- Major hybrid component locations and descriptions.

By following the information in this guide, dismantlers will be able to handle Camry hybrid-electric vehicles as safely as the dismantling of a conventional non-hybrid automobile.

© 2011 Toyota Motor Corporation

All rights reserved. This book may not be reproduced or copied, in whole or in part, without the written permission of Toyota Motor Corporation.

Table of Contents

| | |
|--|------------------|
| <u>About the Camry Hybrid</u> | <u>1</u> |
| <u>Camry Hybrid Identification</u> | <u>2</u> |
| Exterior | 3 |
| <u>Camry Hybrid Identification (Continued)</u> | <u>4</u> |
| Interior..... | 4 |
| Engine Compartment | 5 |
| <u>Hybrid Component Locations & Descriptions</u> | <u>6</u> |
| Specifications | 7 |
| <u>Hybrid Synergy Drive Operation</u> | <u>8</u> |
| Vehicle Operation..... | 8 |
| <u>Hybrid Vehicle (HV) Battery Pack and Auxiliary Battery</u> | <u>9</u> |
| HV Battery Pack..... | 9 |
| Components Powered by the HV Battery Pack..... | 9 |
| HV Battery Pack Recycling | 10 |
| Auxiliary Battery | 10 |
| <u>High Voltage Safety</u> | <u>11</u> |
| High Voltage Safety System..... | 11 |
| Service Plug Grip | 12 |
| <u>Precaution to be observed when dismantling the vehicle</u> | <u>13</u> |
| Necessary Items | 13 |
| <u>Spills</u> | <u>14</u> |
| <u>Dismantling the vehicle</u> | <u>14</u> |
| <u>Removal of HV battery</u> | <u>18</u> |
| HV Battery Caution Label | 30 |

About the Camry Hybrid

The Camry hybrid continues into its 2nd generation as a gasoline-electric hybrid vehicle. Hybrid Synergy Drive means that the vehicle contains a gasoline engine and electric motors for power. The two hybrid power sources are stored on board the vehicle:

1. Gasoline stored in the fuel tank for the gasoline engine.
2. Electricity stored in a high voltage Hybrid Vehicle (HV) battery pack for the electric motor.

The result of combining these two power sources is improved fuel economy and reduced emissions. The gasoline engine also powers an electric generator to recharge the battery pack; unlike a pure all electric vehicle, the Camry hybrid never needs to be recharged from an external electric power source.

Depending on the driving conditions one or both sources are used to power the vehicle. The following illustration demonstrates how the Camry hybrid operates in various driving modes.

- ❶ During light acceleration at low speeds, the vehicle is powered by the electric motor. The gasoline engine is shut off.
- ❷ During normal driving, the vehicle is powered mainly by the gasoline engine. The gasoline engine also powers the generator to recharge the battery pack.
- ❸ During full acceleration, such as climbing a hill, both the gasoline engine and the electric motor power the vehicle.
- ❹ During deceleration, such as when braking, the vehicle regenerates the kinetic energy from the wheels to produce electricity that recharges the battery pack.
- ❺ While the vehicle is stopped, the gasoline engine and electric motor are off, however the vehicle remains on and operational.

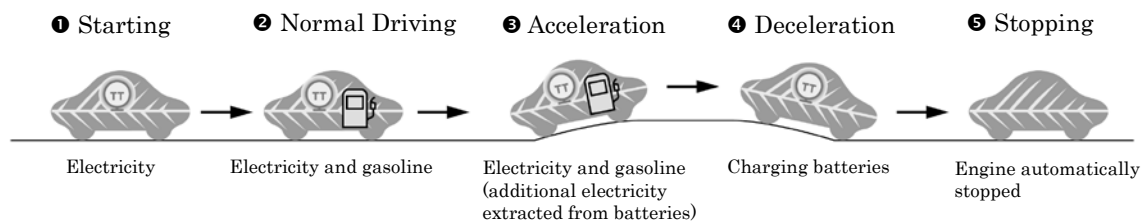

Camry Hybrid Identification

In appearance, the 2012 model Camry hybrid is a 4-door sedan. Exterior, interior, and engine compartment illustrations are provided to assist in identification.

The alphanumeric 17 character Vehicle Identification Number (VIN) is provided under the right side front seat and left side door pillar.

Example VIN: 4T1BD1FK0CU001001

A Camry hybrid is identified by the first 8 alphanumeric characters **4T1BD1FK**.

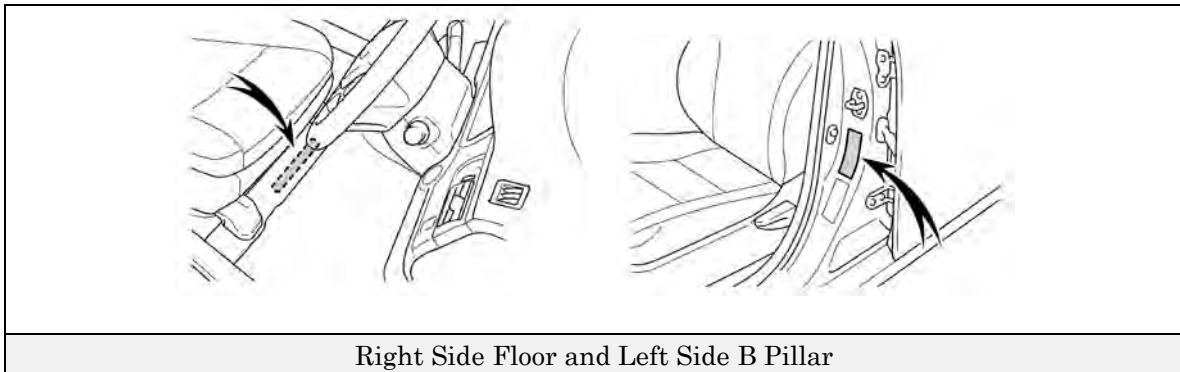

Camry Hybrid Identification (Continued)

Exterior

- ❶ **HYBRID** and  logo on the trunk lid.
- ❷ **CAMRY** logo on the left side of the trunk lid.
- ❸ **HYBRID** logo on each front fender.



Exterior Left Side View



Exterior Front View



Exterior Rear View



Exterior Rear and Left Side View

Camry Hybrid Identification (Continued)

Interior

- ④ Instrument cluster (speedometer, **READY** light, shift state indicators, warning lights) located in the center of the dash and near the base of the windshield.

Hint:

If the vehicle is shut off, the instrument cluster gauges will be “blacked out”, not illuminated.

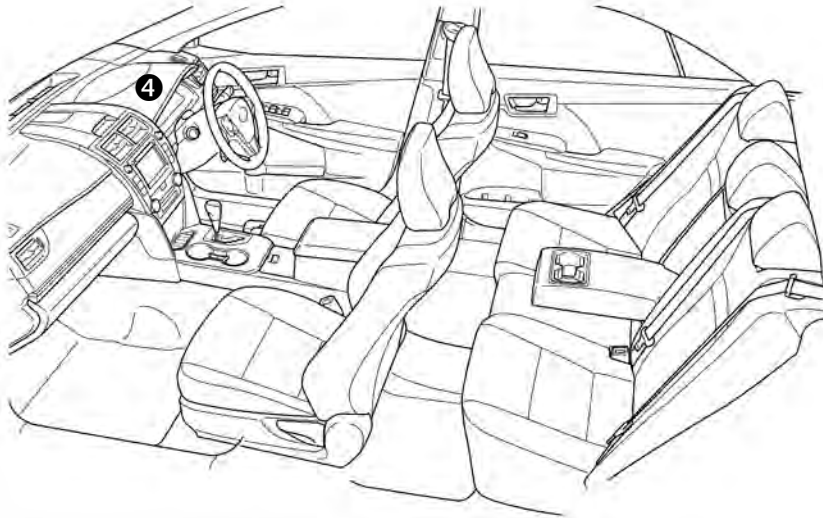

Interior View of Front Door Sill

④

READY Indicator

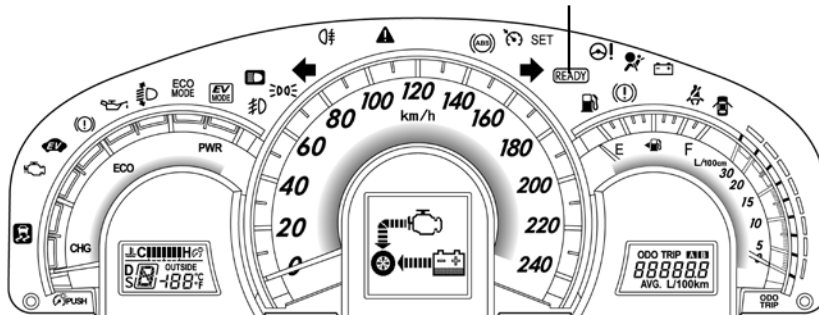

Instrument Cluster View

Camry Hybrid Identification (Continued)

Engine Compartment

- ⑤ 2.5-liter aluminum alloy gasoline engine.
- ⑥ Logo on the plastic engine cover.
- ⑦ Orange colored high voltage power cables.

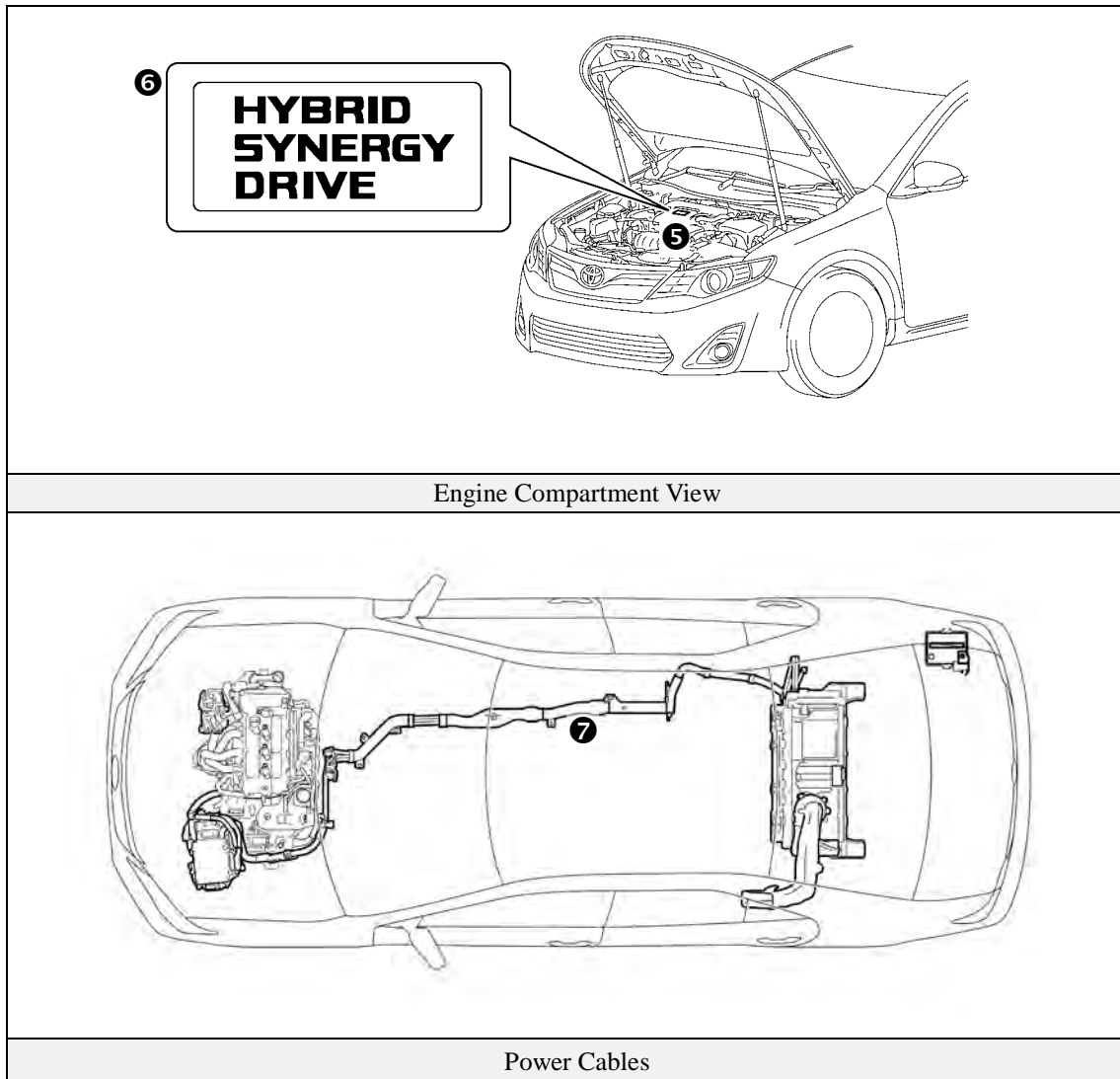

Hybrid Component Locations & Descriptions

| Component | Location | Description |
|------------------------------------|---|--|
| 12 Volt ❶ Auxiliary Battery | Right Side of Trunk | A lead-acid battery that supplies power to the low voltage devices. |
| Hybrid ❷ Vehicle (HV) Battery Pack | Trunk, Mounted to Cross Member behind Rear Seat | 244.8 Volt Nickel Metal Hydride (NiMH) battery pack consisting of 34 low voltage (7.2 Volt) modules connected in series. |
| Power ❸ Cables | Undercarriage and Engine Compartment | Orange colored power cables carry high voltage Direct Current (DC) between the HV battery pack, inverter/converter, and A/C compressor. These cables also carry 3-phase Alternating Current (AC) between the inverter/converter, electric motor, and generator. |
| Inverter/Converter ❹ | Engine Compartment | Boosts and inverts the high voltage electricity from the HV battery pack to 3-phase AC electricity that drives the electric motors. The inverter/converter also converts AC electricity from the electric generator and electric motors (regenerative braking) to DC that recharges the HV battery pack. |
| Gasoline ❺ Engine | Engine Compartment | Provides two functions: 1) Powers vehicle. 2) Powers generator to recharge the HV battery pack. The engine is started and stopped under control of the vehicle computer. |
| Electric ❻ Motor | Engine Compartment | 3-phase high voltage AC permanent magnet electric motor contained in the front transaxle. It is used to power the front wheels. |
| Electric ❼ Generator | Engine Compartment | 3-phase high voltage AC generator that is contained in the transaxle and recharges the HV battery pack. |
| A/C Compressor (with Inverter) ❸ | Engine Compartment | 3-phase high voltage AC electrically driven motor compressor. |
| Fuel Tank and Fuel Line ❹ | Undercarriage and Center | The fuel tank provides gasoline via a fuel line to the engine. The fuel line is routed under the center of vehicle. |

*Numbers in the component column apply to the illustrations on the following page.

Hybrid Component Locations & Descriptions (Continued)

Specifications

- Gasoline Engine: 158 hp (118 kW), 2.5-liter Aluminum Alloy Engine
- Electric Motors 141 hp (105 kW), Permanent Magnet Motor
- Transmission: Automatic Only (electrically controlled continuously variable transaxle)
- HV Battery: 244.8 Volt Sealed NiMH-Battery
- Curb Weight: 3,483 lbs/1,580 kg
- Fuel Tank: 17.2 gals/65.0 liters
- Frame Material: Steel Unibody
- Body Material: Steel Panel
- Seating Capacity: 5 standard

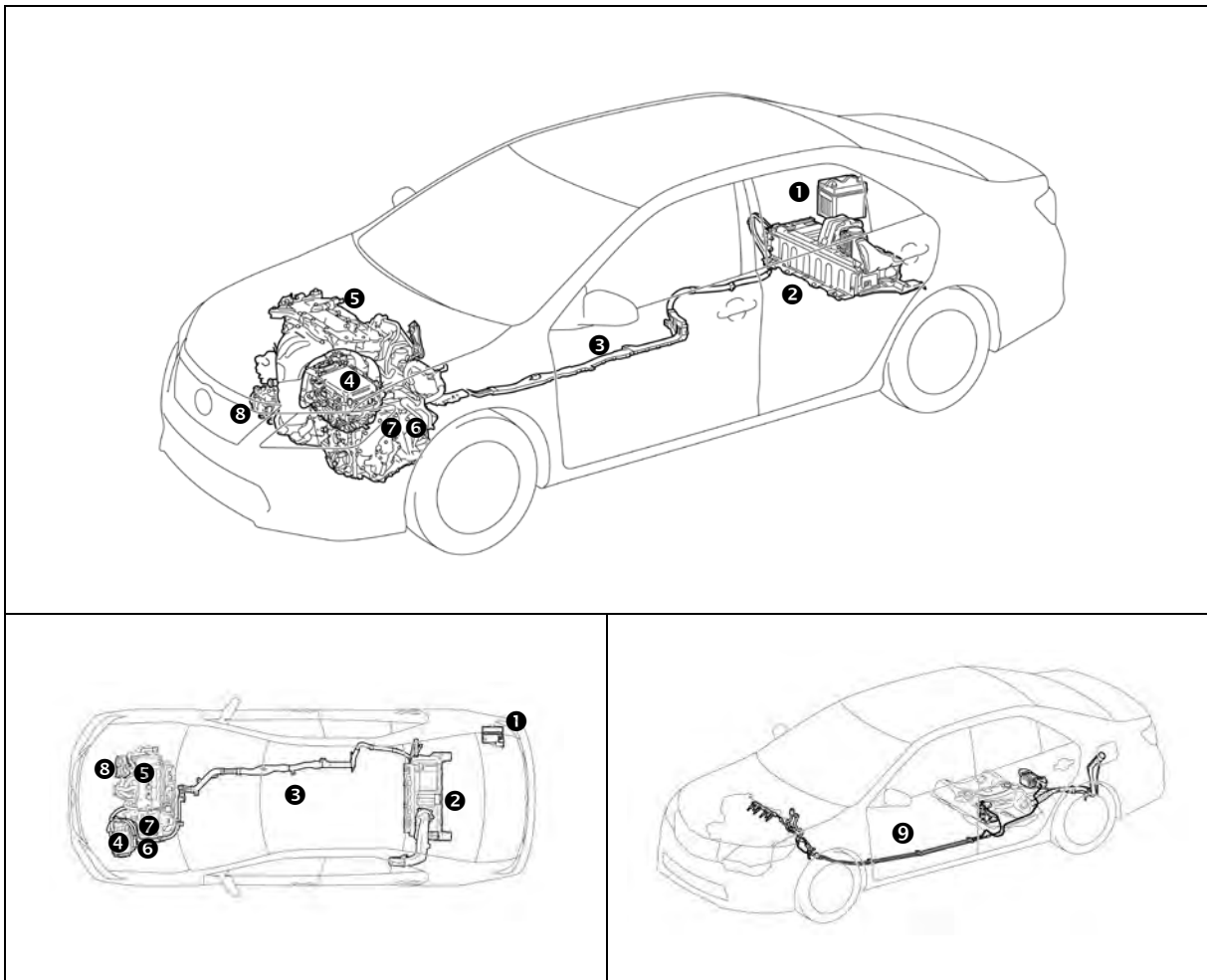

Hybrid Synergy Drive Operation

Once the **READY** indicator is illuminated in the instrument cluster, the vehicle may be driven. However, the gasoline engine does not idle like a typical automobile and will start and stop automatically. It is important to recognize and understand the **READY** indicator provided in the instrument cluster. When illuminated, it informs the driver that the vehicle is on and operational even though the gasoline engine may be off and the engine compartment is silent.

Vehicle Operation

- With the Camry hybrid, the gasoline engine may stop and start at any time while the **READY** indicator is on.
- Never assume that the vehicle is shut off just because the engine is off. Always look for the **READY** indicator status. The vehicle is shut off when the **READY** indicator is off.

The vehicle may be powered by:

1. The electric motor only.
2. A combination of both the electric motor and the gasoline engine.

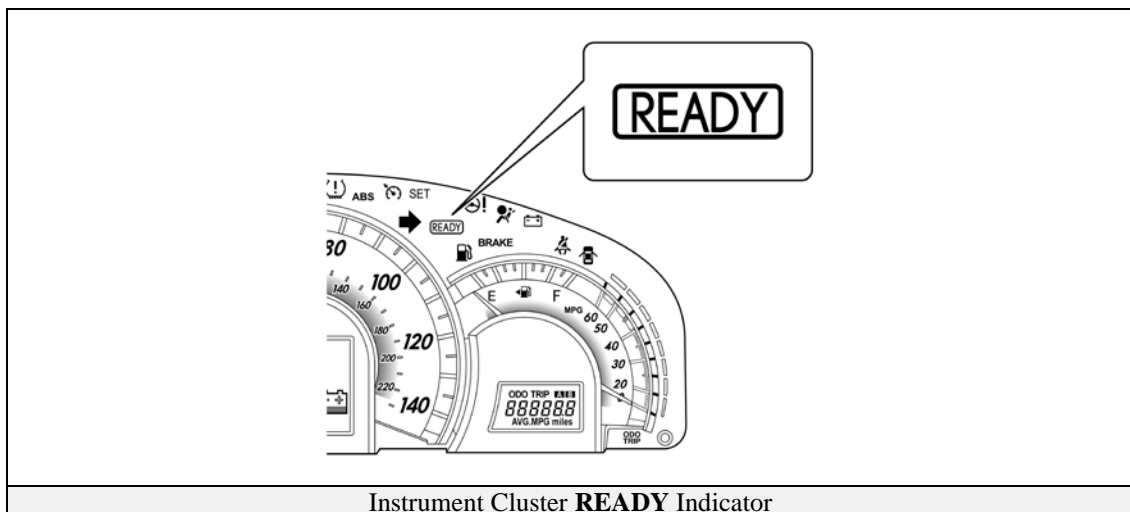

Hybrid Vehicle (HV) Battery Pack and Auxiliary Battery

The Camry hybrid features a high voltage Hybrid Vehicle (HV) battery pack that contains sealed Nickel Metal Hydride (NiMH) battery modules.

HV Battery Pack

- The HV battery pack is enclosed in a metal case and is rigidly mounted to the trunk floor pan cross member behind the rear seat. The metal case is isolated from high voltage and concealed by carpet in the cabin area.
- The HV battery pack consists of 34 low voltage (7.2 Volt) NiMH battery modules connected in series to produce approximately 244.8 Volts. Each NiMH battery module is non-spillable and in a sealed case.
- The electrolyte used in the NiMH battery module is an alkaline mixture of potassium and sodium hydroxide. The electrolyte is absorbed into the battery cell plates and will not normally leak, even in a collision.
- In the unlikely event that the battery pack is overcharged, the modules vent gases directly outside the vehicle through a vent hose.

| | General |
|--|---|
| Battery pack voltage | 244.8 V |
| Number of NiMH battery modules in the pack | 34 |
| NiMH battery module voltage | 7.2 V |
| NiMH battery module dimensions | 11 x 4.6 x 4.6 in (285 x 0.8 x 117.8 mm) |
| NiMH module weight | 2.3 lbs (1.04 kg) |
| NiMH battery pack dimensions | 35.8 x 19.1 x 12.5 in (909 x 486 x 317 mm) |
| NiMH battery pack weight | 107 lbs (49 kg) |

Components Powered by the HV Battery Pack

- Electric Motor
- Inverter/Converter Motor
- Power Cables
- A/C Compressor
- Electric Generator

Hybrid Vehicle (HV) Battery Pack and Auxiliary Battery (Continued)

HV Battery Pack Recycling

- The HV battery pack is recyclable. Contact either your Toyota Distributor as mentioned on HV battery Caution Label (see page 26) or the nearest Toyota dealer.

Auxiliary Battery

- The Camry hybrid also contains a lead-acid 12 Volt battery. This 12 Volt auxiliary battery powers the vehicle electrical system similar to a conventional vehicle. As with other conventional vehicles, the auxiliary battery is grounded to the metal chassis of the vehicle.
- The auxiliary battery is located in the trunk. It is concealed by the deck board and auxiliary box on the right side in the rear quarter panel well.

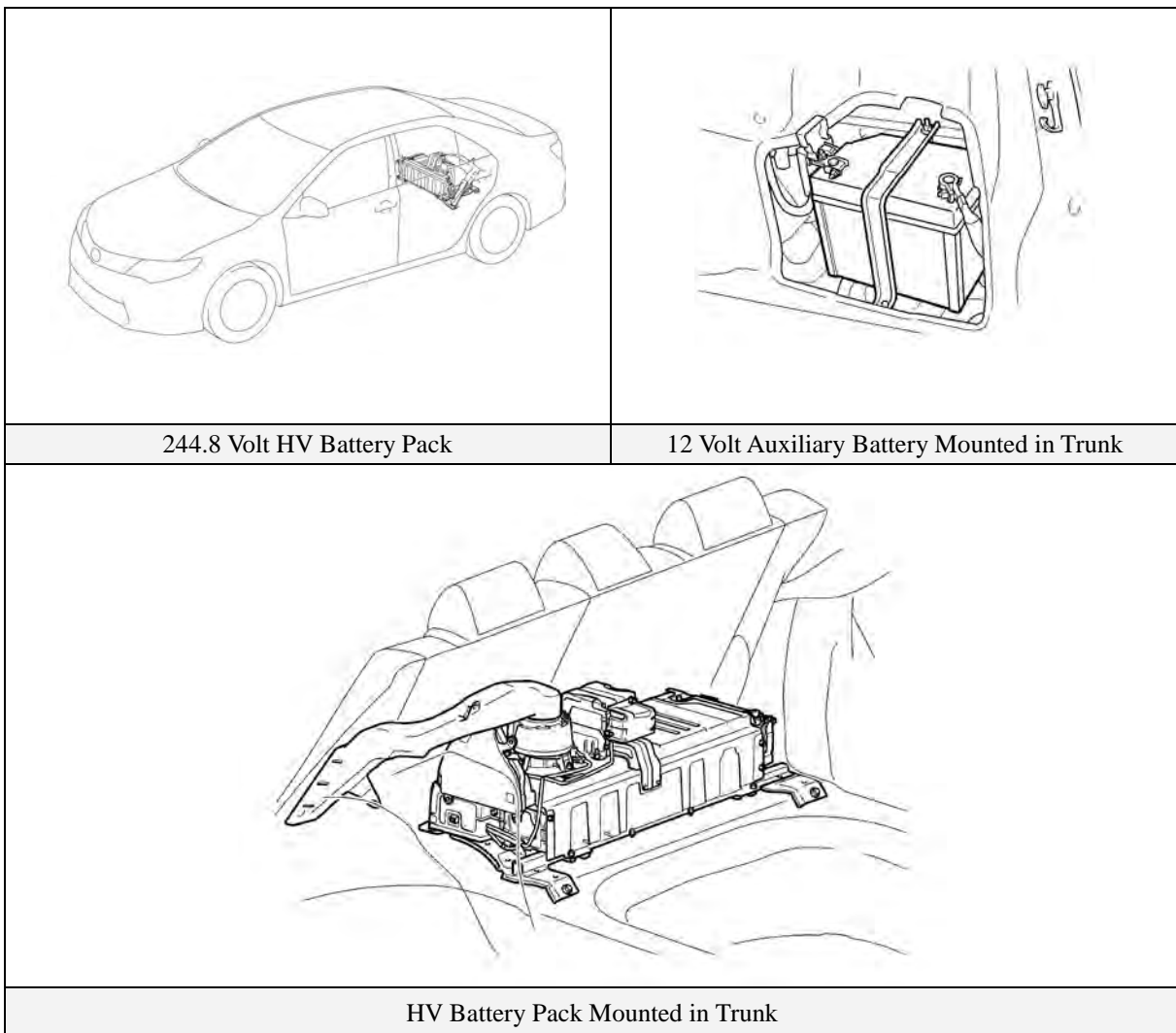

High Voltage Safety

The HV battery pack powers the high voltage electrical system with DC electricity. Positive and negative orange colored high voltage power cables are routed from the battery pack, under the vehicle floor pan, to the inverter/converter. The inverter/converter contains a circuit that boosts the HV battery voltage from 244.8 to 650 Volts DC. The inverter/converter creates 3-phase AC to power the motors. Power cables are routed from the inverter/converter to each high voltage motor (electric motor, electric generator, and A/C compressor). The following systems are intended to help keep occupants in the vehicle and emergency responders safe from high voltage electricity:

High Voltage Safety System

- A high voltage fuse ❶* provides short circuit protection in the HV battery pack.
- Positive and negative high voltage power cables ❷* connected to the HV battery pack are controlled by 12 Volt normally open relays ❸*. When the vehicle is shut off, the relays stop electricity flow from leaving the HV battery pack.



WARNING:

- ***The high voltage system may remain powered for up to 10 minutes after the vehicle is shut off or disabled. To prevent serious injury or death from severe burns or electric shock, avoid touching, cutting, or opening any orange high voltage power cable or high voltage component.***

- Both positive and negative power cables ❷* are insulated from the metal chassis, so there is no possibility of electric shock when touching the metal chassis.
- A ground-fault monitor continuously monitors for high voltage leakage to the metal chassis while the vehicle is running. If a malfunction is detected, the hybrid vehicle computer ❹* will illuminate the master warning light  in the instrument cluster and indicate “CHECK HYBRID SYSTEM” on the multi-information display.
- The HV battery pack relays will automatically open to stop electricity flow in a collision sufficient to activate the SRS.

*Numbers apply to the illustration on the following page.

High Voltage Safety (Continued)

Service Plug Grip

- The high-voltage circuit is cut by removing the service plug grip (see page 15).

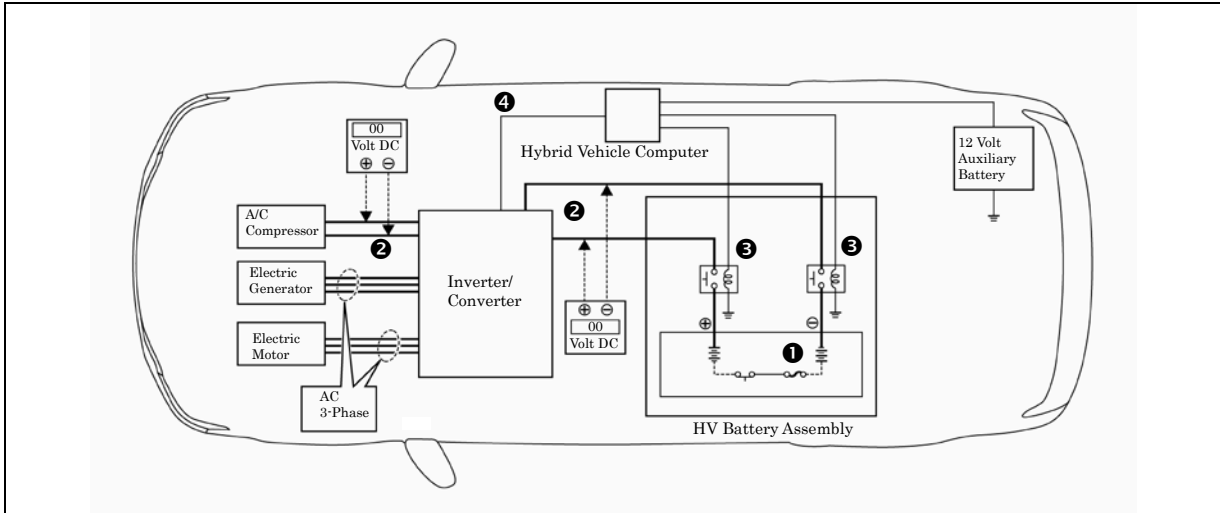

High Voltage Safety System – Vehicle Shut Off (**READY-OFF**)

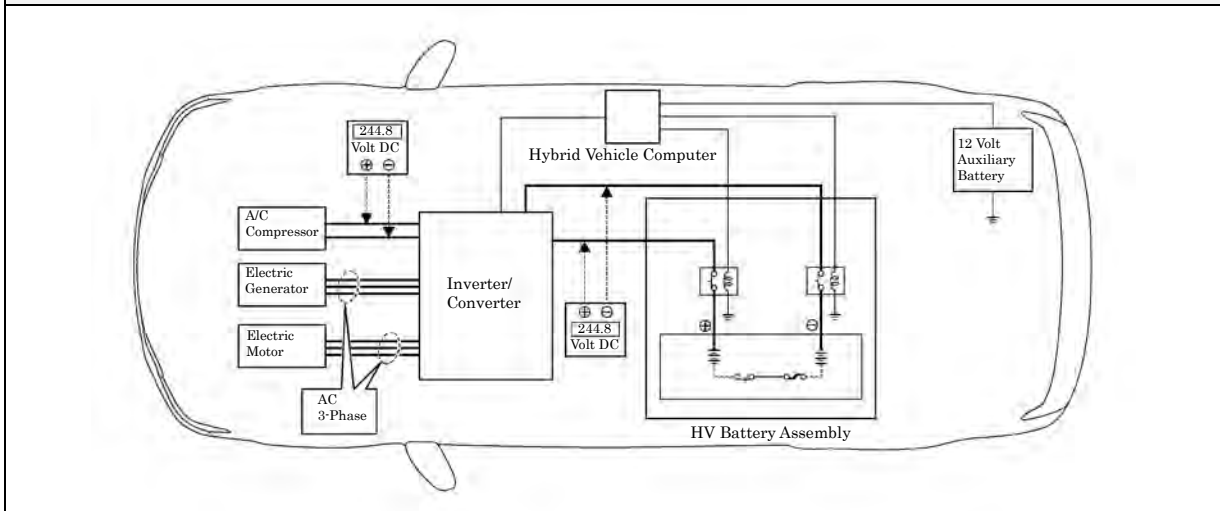

High Voltage Safety System – Vehicle On and Operational (**READY-ON**)

Precaution to be observed when dismantling the vehicle



WARNING:

- *The high voltage system may remain powered for up to 10 minutes after the vehicle is shut off or disabled. To prevent serious injury or death from severe burns or electric shock, avoid touching, cutting, or opening any orange high voltage power cable or high voltage component.*

Necessary Items

- Protective clothing such as insulated gloves (electrically insulated), rubber gloves, safety goggles, and safety shoes.
- Insulating tape such as electrical tape that has a suitable electrical insulation rating.
- Before wearing insulated gloves, make sure that they are not cracked, ruptured, torn, or damaged in any way. Do not wear wet insulated gloves.
- An electrical tester that is capable of measuring DC 750 Volts or more.

Spills

The Camry hybrid contains the same common automotive fluids used in other non-hybrid Toyota vehicles, with the exception of the NiMH electrolyte used in the HV battery pack. The NiMH battery electrolyte is a caustic alkaline (pH 13.5) that is damaging to human tissues. The electrolyte, however, is absorbed in the cell plates and will not normally spill or leak out even if a battery module is cracked. A catastrophic crash that would breach both the metal battery pack case and a metal battery module would be a rare occurrence.

A caustic alkaline is at the opposite end of the pH scale from a strong acid. A safe (neutral) substance is approximately in the middle of this scale. Adding a weak acidic mixture, such as a dilute boric acid solution or vinegar, to the caustic alkaline electrolyte will cause the electrolyte to be neutralized. This is similar but opposite to the use of baking soda to neutralize a lead-acid battery electrolyte spill.

A Toyota Material Safety Data Sheets (MSDS) is attached to this document.

- Handle NiMH electrolyte spills using the following Personal Protective Equipment (PPE):
 - Splash shield or safety goggles. A fold down face shield is not acceptable for acid or electrolyte spills.
 - Rubber, latex or nitrile gloves.
 - Apron suitable for alkaline.
 - Rubber boots.
- Neutralize NiMH electrolyte.
 - Use a boric acid solution or vinegar.
 - Boric acid solution - 800 grams boric acid to 20 liters water or 5.5 ounces boric acid to 1 gallon of water.

Dismantling the vehicle

The following 2 pages contain general instructions for use when working on a Camry hybrid. Read these instructions before proceeding to the HV battery removal instructions on page 18.



WARNING:

- ***The high voltage system may remain powered for up to 10 minutes after the vehicle is shut off or disabled. To prevent serious injury or death from severe burns or electric shock, avoid touching, cutting, or opening any orange high voltage power cable or any high voltage component.***

1. Shut off the ignition (**READY** indicator is off).
Then disconnect the cable from the auxiliary battery negative (-) terminal.
 - (1) Remove the 3 deck boards.
 - (2) Remove the auxiliary boxes.
 - (3) Disconnect the battery negative terminal.

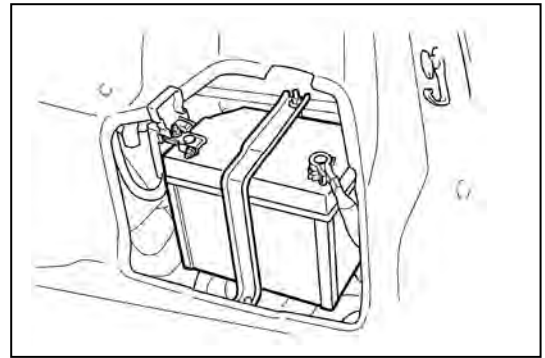

2. Remove No. 8 hybrid vehicle battery shield panel.
 - (1) Remove the 2 nuts and No. 8 hybrid vehicle battery shield panel.
3. Remove the service plug grip.

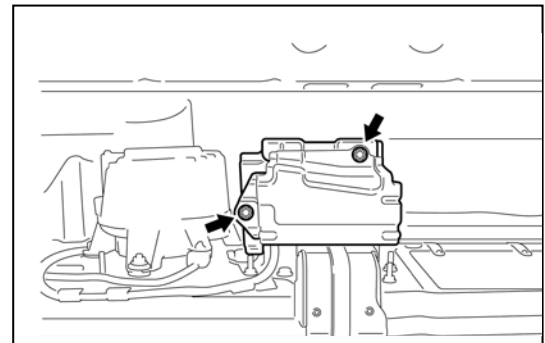

Caution:

Wear insulated gloves for the following 3 steps.

- (1) Slide the handle of the service plug grip to the right.
- (2) Raise the release handle of the service plug grip
- (3) Remove the service plug grip.
- (4) Apply insulating tape to the socket of the service plug grip to insulate it.

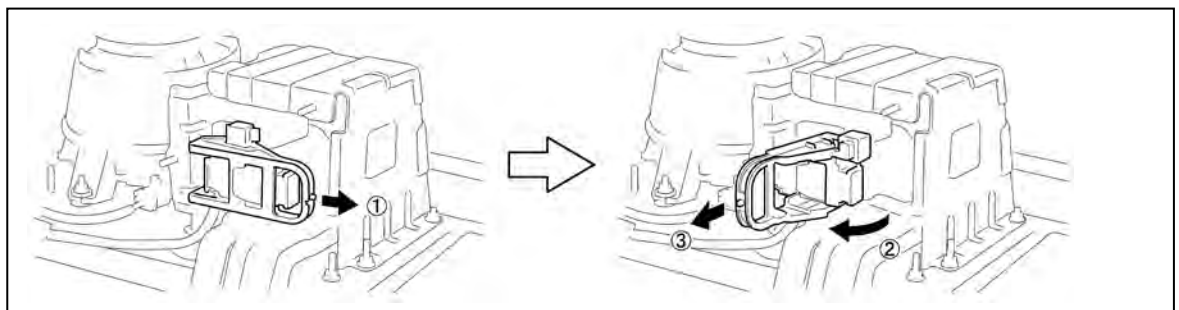

4. Carry the removed service plug grip in your pocket to prevent other staff from accidentally reinstalling it while you are dismantling the vehicle.
5. Make other staff aware that a high-voltage system is being dismantled by using the following sign: CAUTION: HIGH-VOLTAGE. DO NOT TOUCH (see page 17).
6. If the service plug grip cannot be removed due to damage to the vehicle, remove the **IG2 MAIN** fuse (25A).

Caution:

This operation shuts off the HV system. Be sure to wear insulated gloves because high voltage is not shut off inside the HV battery. When it is possible to remove the service plug grip, remove it and continue the procedure.

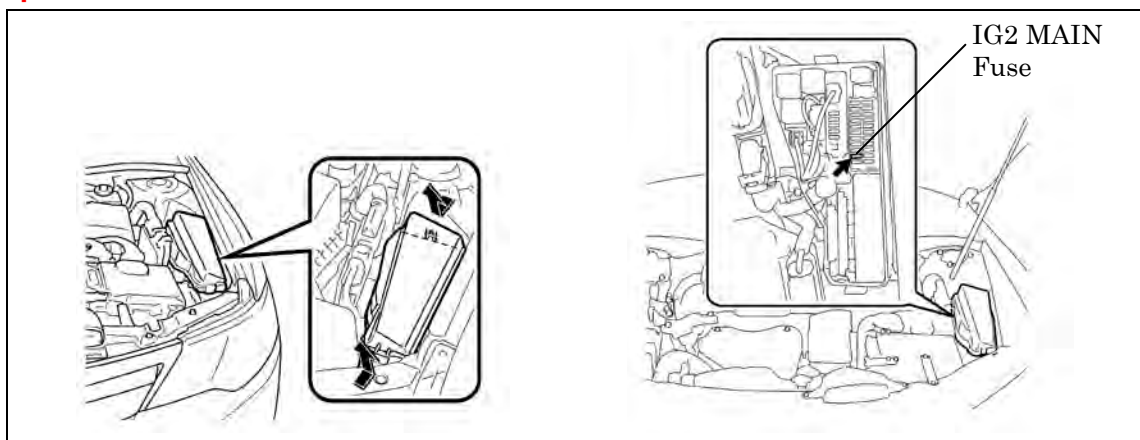

7. After disconnecting or exposing a high-voltage connector or terminal, insulate it immediately using insulating tape. Before disconnecting or touching a bare high-voltage terminal, wear insulated gloves.
8. Check the HV battery and nearby area for leakage. If you find any liquid, it may be strong alkaline electrolyte. Wear rubber gloves and goggles and neutralize the liquid using a saturated boric acid solution or vinegar. Then wipe up the liquid using waste rags etc.
9. If the electrolyte comes into contact with your skin, wash the skin immediately using a saturated boric acid solution or a large amount of water. If the electrolyte adheres to any article of clothing, take the clothing off immediately.
10. If the electrolyte comes into contact with your eye(s), call out loudly for help. Do not rub your eye(s). Instead, wash the eye(s) with a dilute boric acid solution or a large amount of water and seek medical care.
11. With the exception of the HV battery, remove parts by following procedures which are similar to conventional Toyota vehicles. For the removal of the HV battery, refer to the following pages.

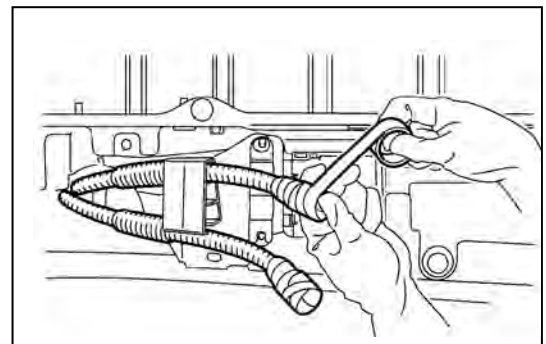

Person in charge: _____

CAUTION:
HIGH-VOLTAGE.
DO NOT TOUCH.

CAUTION:
HIGH-VOLTAGE.
DO NOT TOUCH.

Person in charge: _____

When performing work on the HV system, fold this sign and
put it on the roof of the vehicle.

Removal of HV battery



WARNING:

- **Be sure to wear insulated gloves when handling high-voltage parts.**
- **Even if the vehicle is shut off and the relays are off, be sure to remove the service plug grip before performing any further work.**
- **Power remains in the high voltage electrical system for 10 minutes even after the HV battery pack is shut off because the circuit has a condenser that stores power.**
- **Make sure that the tester reading is 0 V before touching any high-voltage terminals which are not insulated.**
- **The SRS may remain powered for up to 90 seconds after the vehicle is shut off or disabled. To prevent serious injury or death from unintentional SRS deployment, avoid cutting the SRS components.**

1. SHUT OFF IGNITION (**READY** indicator is off)
2. REMOVE LUGGAGE TRIM SERVICE HOLE COVER

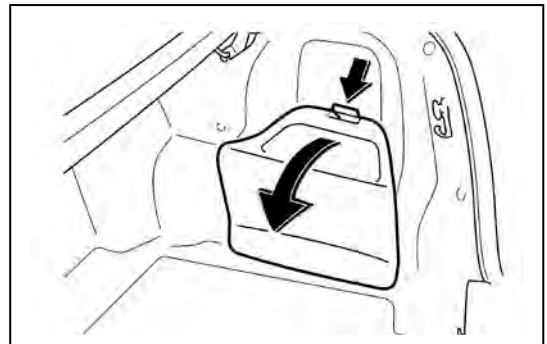

3. REMOVE 12 V AUXILIARY BATTERY
 - (1) Disconnect the cable from the auxiliary battery negative (-) terminal.
 - (2) Disconnect the cable from the auxiliary battery positive (+) terminal.
 - (3) Remove the 12 volt auxiliary battery.

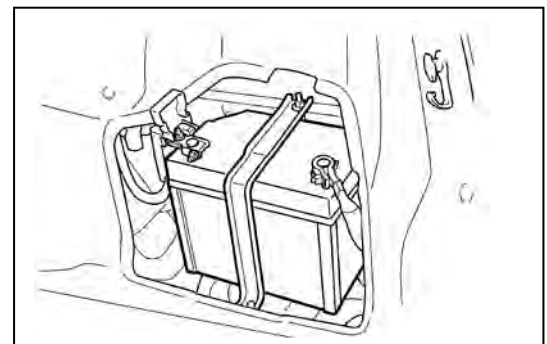

4. REMOVE LUGGAGE COMPARTMENT FLOOR MAT
5. REMOVE SPARE WHEEL COVER ASSEMBLY

6. REMOVE LUGGAGE COMPARTMENT FRONT TRIM COVER

- (1) Disengage the 8 fasteners.
- (2) Disengage the 3 claws and remove the luggage compartment front trim cover.

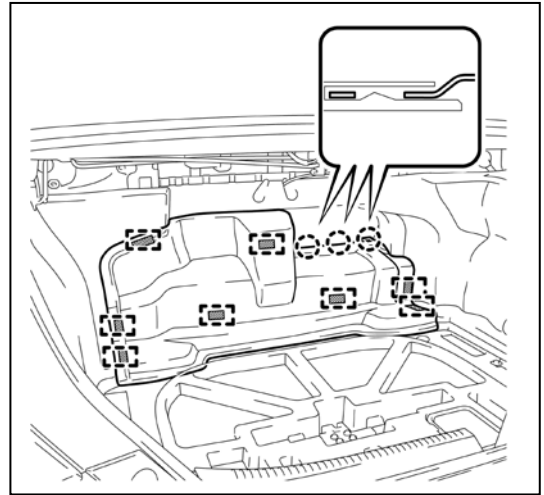

7. REMOVE NO. 8 HYBRID VEHICLE BATTERY SHIELD PANEL

- (1) Remove the 2 nuts and No. 8 hybrid vehicle battery shield panel.

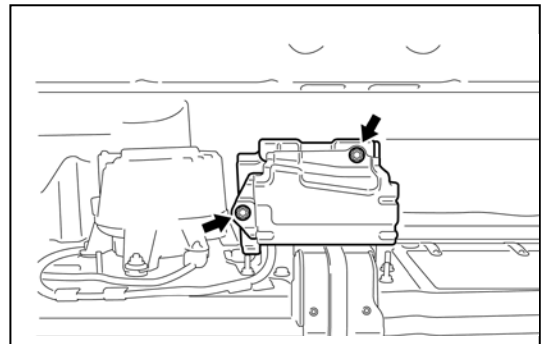

8. REMOVE SERVICE PLUG GRIP

Caution:

Wear insulated gloves for the following 3 steps.

- (1) Slide the handle of the service plug grip.
- (2) Raise the release handle of the service plug grip as shown in the illustration below.
- (3) Remove the service plug grip.
- (4) Apply insulating tape to the socket of the service plug grip to insulate it.

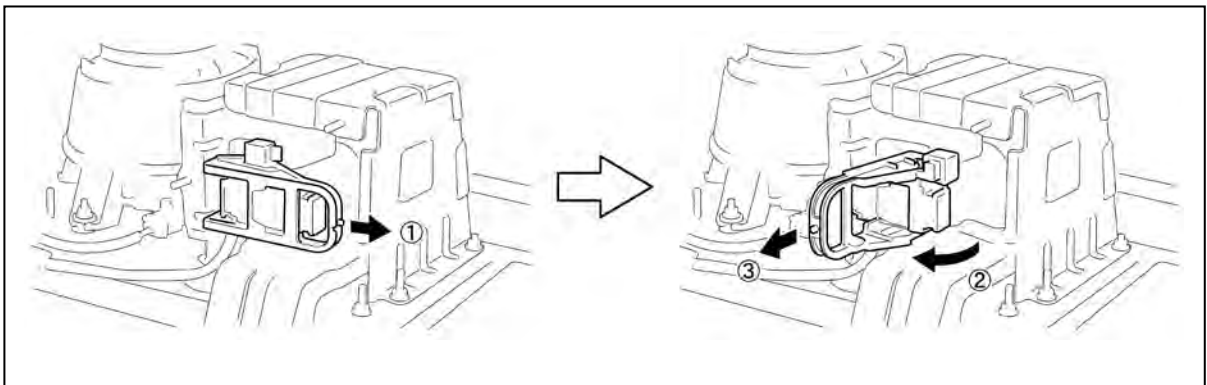

9. REMOVE CONNECTOR COVER ASSEMBLY

Caution:

Wear insulated gloves.

- (1) Remove the 2 bolts and connector cover assembly.

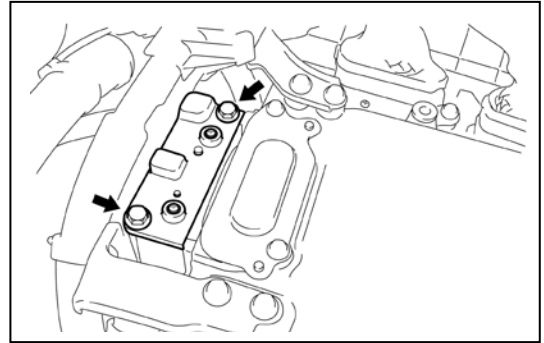

10. CHECK TERMINAL VOLTAGE

- (1) Check voltage at the terminals in inspection point in the power control unit.

Caution:

Wear insulated gloves.

To prevent serious injury or death, do not proceed with dismantling of the HV system until the voltage at the terminals in the inspection point is 0 V.

Standard voltage: 0 V

Hint:

Set the tester to the DC 750 Volts range to measure the voltage.

This inspection is performed to verify that it is safe to remove the HV battery.

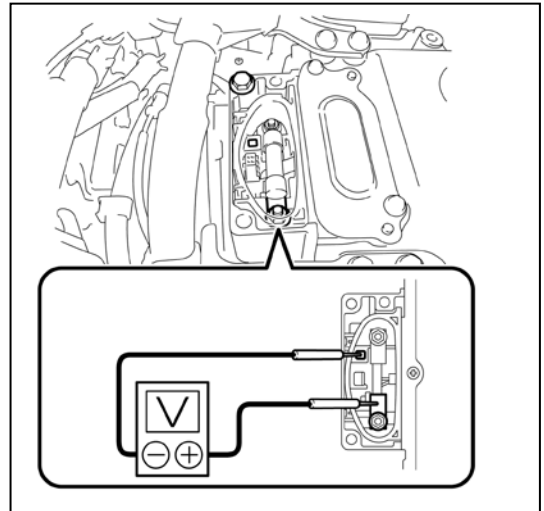

11. REMOVE REAR FLOOR FINISH PLATE

- (1) Remove the 5 clips.

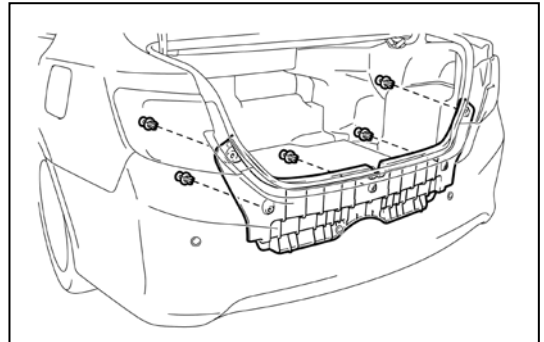

- (2) Disengage the 4 clips and remove the rear floor finish plate.

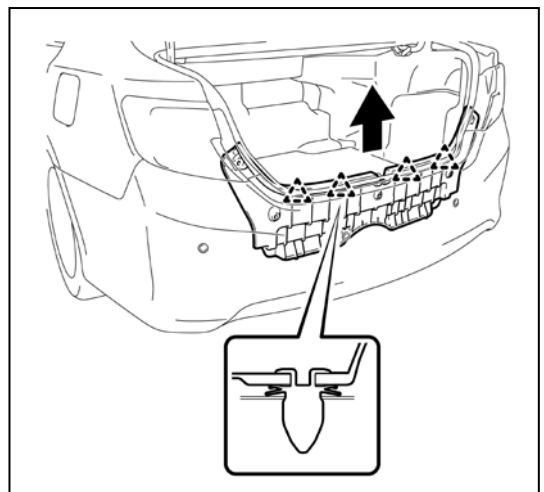

12. REMOVE NO. 1 LUGGAGE
COMPARTMENT TRIM HOOK

- (1) Push the 2 pins and remove the 2 No. 1 luggage compartment trim hooks.

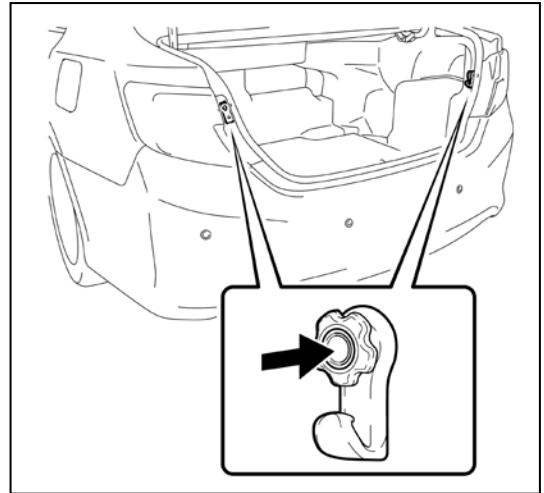

13. REMOVE LUGGAGE COMPARTMENT
INNER TRIM COVER LH

- (1) Remove the 3 clips.
- (2) Disengage the fastener and remove the luggage compartment inner trim cover LH.

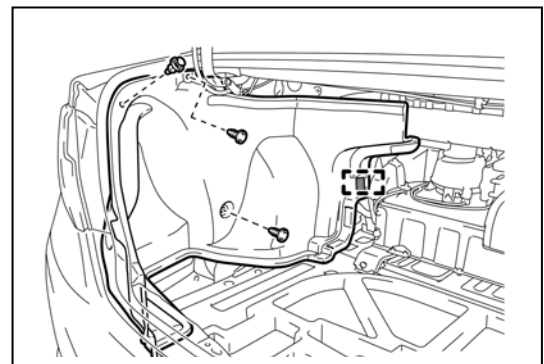

14. REMOVE LUGGAGE COMPARTMENT
INNER TRIM COVER RH

- (1) Remove the 3 clips.
- (2) Disengage the fastener and remove the luggage compartment inner trim cover RH.

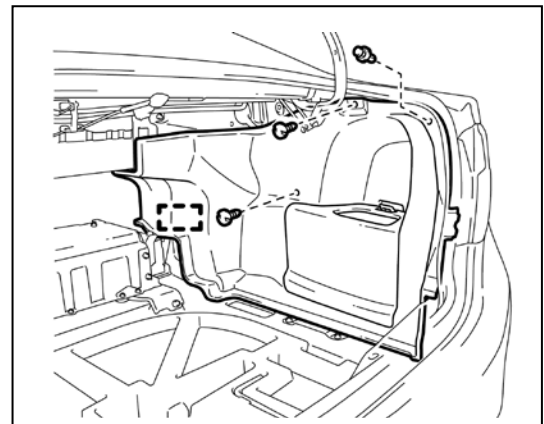

15. REMOVE REAR SEAT CUSHION
ASSEMBLY

- (1) Disengage the hook of the seat cushion from the vehicle body as shown in the illustration.
- (2) Remove the rear seat cushion assembly.

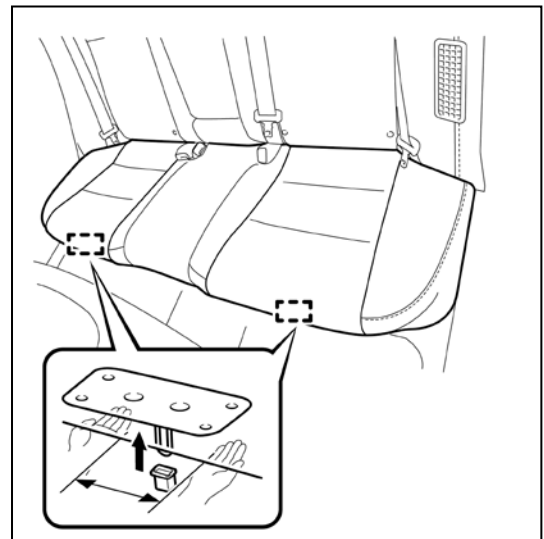

**16. REMOVE REAR SEATBACK ASSEMBLY
RH**

- (1) Disengage the 3 fasteners as shown in the illustration.

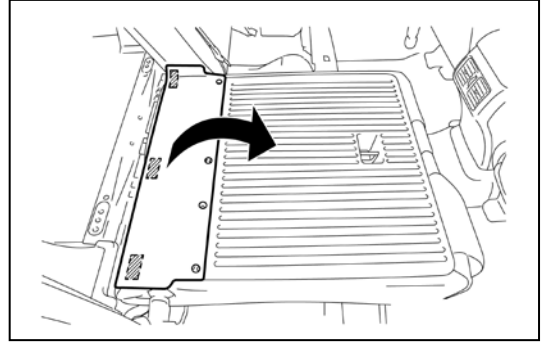

- (2) Remove the 2 bolts and rear seatback assembly RH.

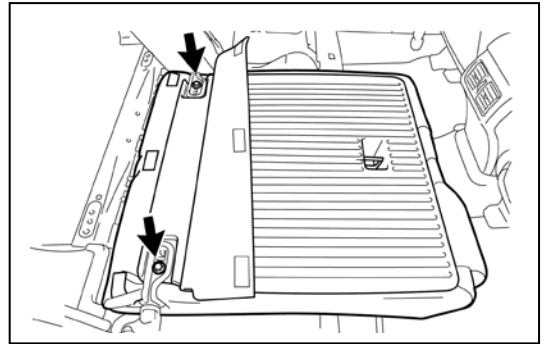

17. REMOVE NO. 2 ROOM PARTITION COVER

- (1) Using a moulding remover, disengage the claw and guide, and remove the No. 2 room partition cover.

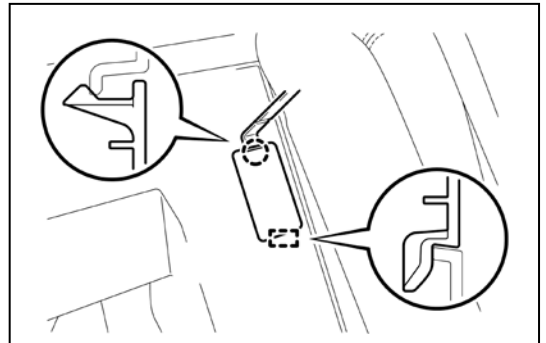

**18. REMOVE REAR SEATBACK ASSEMBLY
LH**

- (1) Pull the cable to relock the seatback lock and fold the rear seatback assembly LH forward.

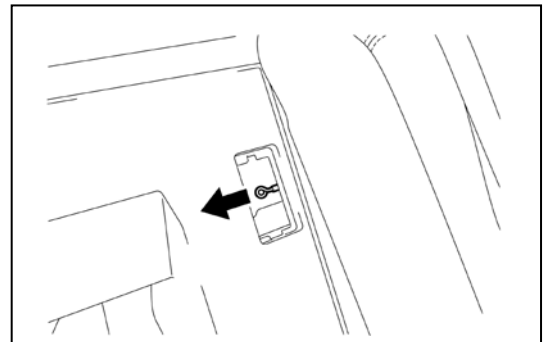

- (2) Disengage the 2 fasteners as shown in the illustration.

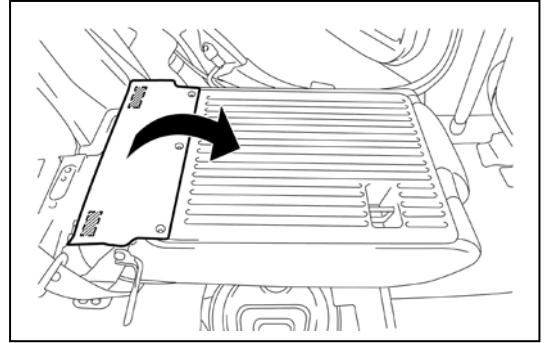

- (3) Remove the 2 bolts and rear seatback assembly LH.

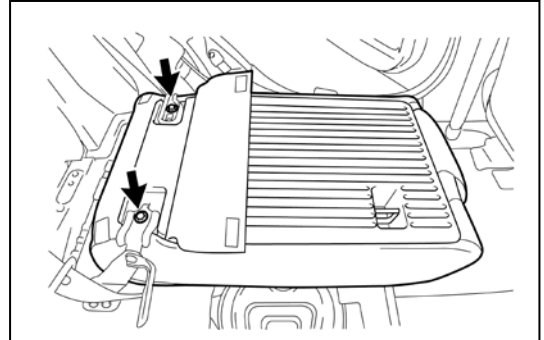

19. REMOVE REAR SIDE SEATBACK ASSEMBLY LH

- (1) Disconnect each connector.
(2) Remove the 2 bolts.
(3) Disengage the hook and remove the rear side seatback assembly LH.

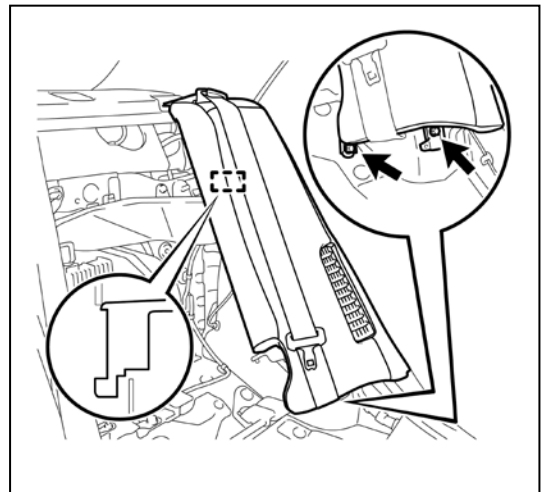

20. REMOVE REAR SIDE SEATBACK ASSEMBLY RH

- (1) Disconnect each connector.
(2) Remove the 2 bolts.
(3) Disengage the hook and remove the rear side seatback assembly RH.

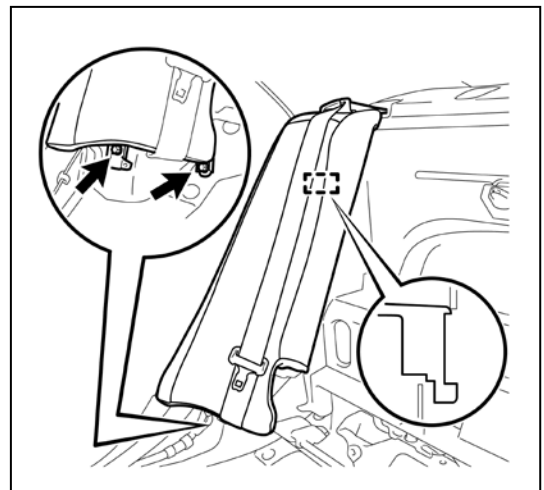

21. CUT REAR SEAT BELT LH, REAR SEAT BELT RH AND REAR SEAT BELT CENTER

22. REMOVE CHILD RESTRAINT SEAT
ANCHOR BRACKET SUB-ASSEMBLY LH

- (1) Remove the 2 nuts and child restraint seat anchor bracket sub-assembly LH.

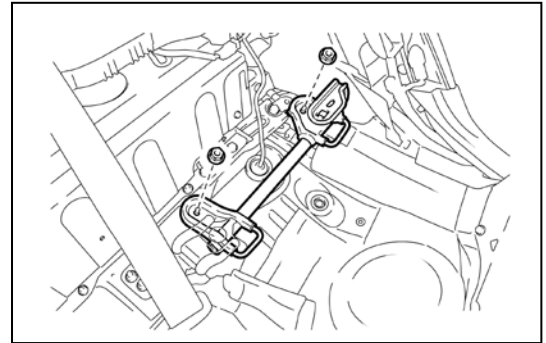

23. DISCONNECT REAR DOOR OPENING
TRIM WEATHERSTRIP LH AND RH

24. REMOVE ROOF SIDE INNER GARNISH LH
AND RH

25. REMOVE CENTER STOP LIGHT SET

- (1) Slide the center stop light set in the order and directions shown by the arrows in the illustration while pushing it towards the rear of the vehicle to disengage the 4 claws.

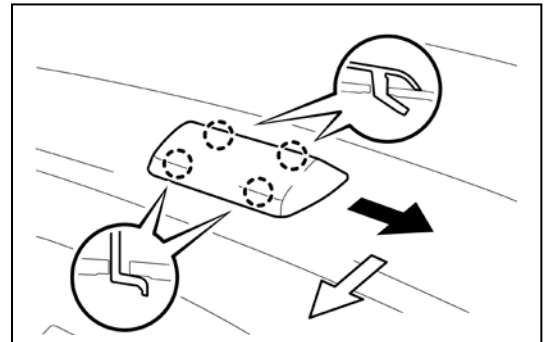

- (2) Turn the center stop light set 180 degrees as shown by the arrow in the illustration.
- (3) Disconnect the connector and remove the center stop light set.

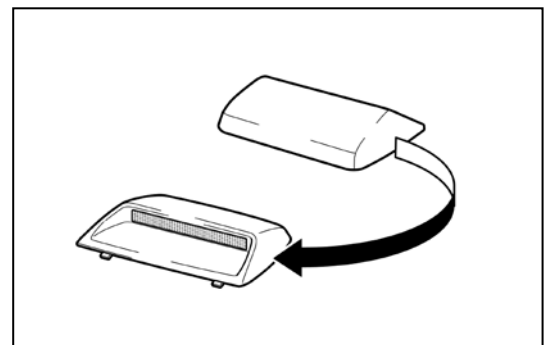

26. REMOVE PACKAGE TRAY TRIM PANEL
ASSEMBLY

- (1) Using pliers, disengage the 3 clips from inside the luggage compartment as shown in the illustration.
- (2) Disengage the 5 guides.
- (3) Pass the 3 rear seat belt floor anchors through the package tray trim panel assembly then remove the package tray trim panel assembly.

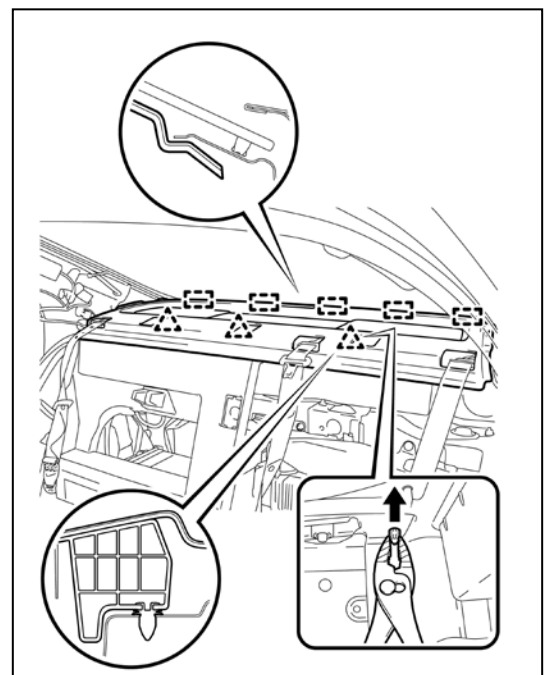

27. REMOVE ROOM PARTITION BOARD

- (1) Using a clip remover, remove the clip.
- (2) Disengage the 5 claws and clip, and remove the room partition board LH.

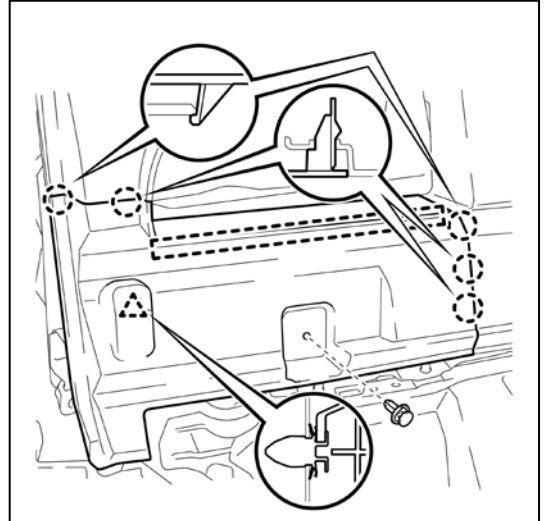

- (3) Using a clip remover, remove the 4 clips.
- (4) Disengage the 4 clips, and remove the room partition board RH.

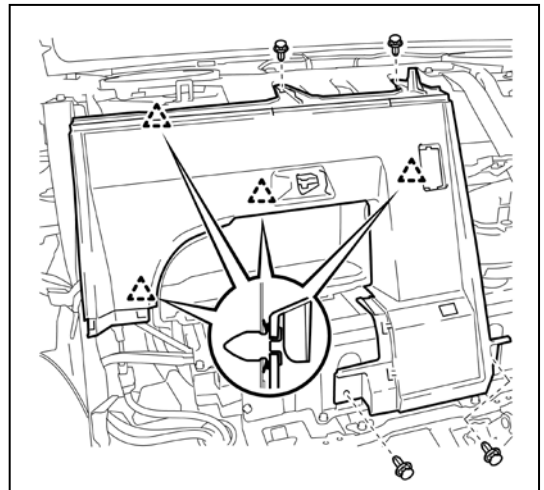

28. REMOVE NO. 1 HYBRID BATTERY INTAKE DUCT

- (1) Remove the 3 clips and No. 1 hybrid battery intake duct.

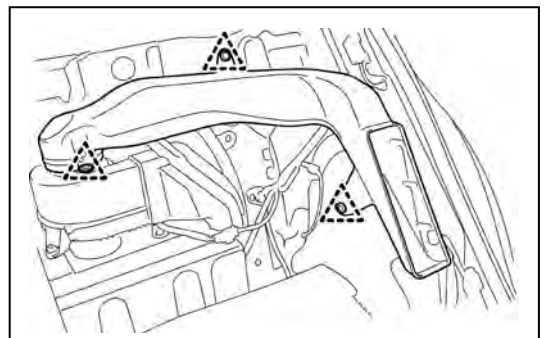

29. REMOVE NO. 4 HYBRID BATTERY SHIELD PANEL

Caution:

Wear insulated gloves for the following 2 steps.

- (1) Remove the 3 clips and No. 1 hybrid battery intake duct.

Hint:

Insert the projecting part of the service plug grip and turn the button of the battery cover lock striker counterclockwise to release the lock.

- (2) Remove the bolt, 2 nuts and No. 4 hybrid battery shield panel.

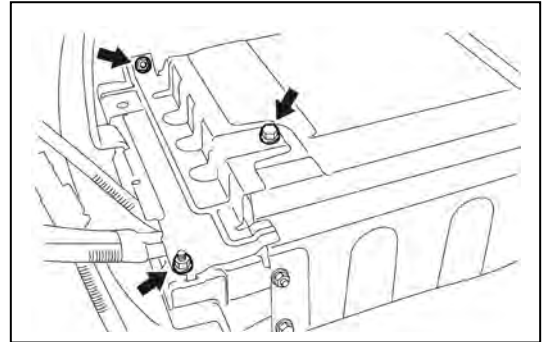
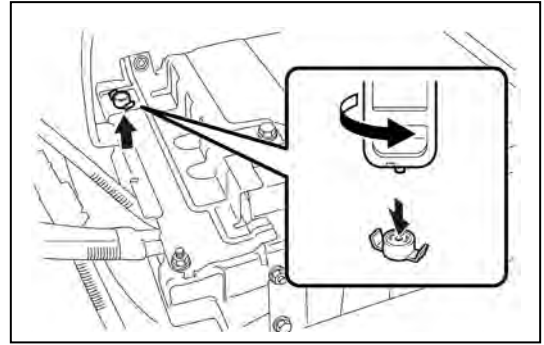

30. REMOVE NO. 4 FLOOR WIRE

Caution:

Wear insulated gloves.

Notice:

Insulate the terminals of the removed frame wire with insulating tape.

- (1) Disconnect the 2 connectors shown in the illustration.
- (2) Disconnect the shielded wire ground and disconnect the No. 4 floor wire.

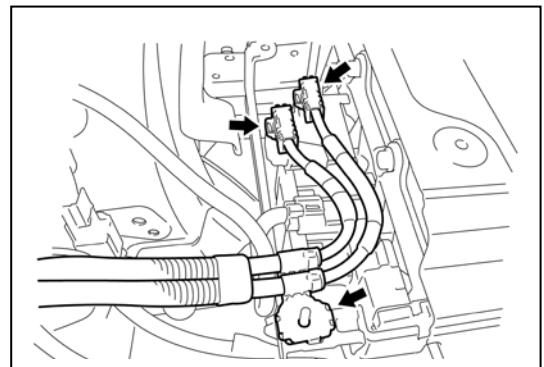

31. DISCONNECT LOW VOLTAGE CONNECTOR

- (1) Disconnect the connector and clamp shown in the illustration.

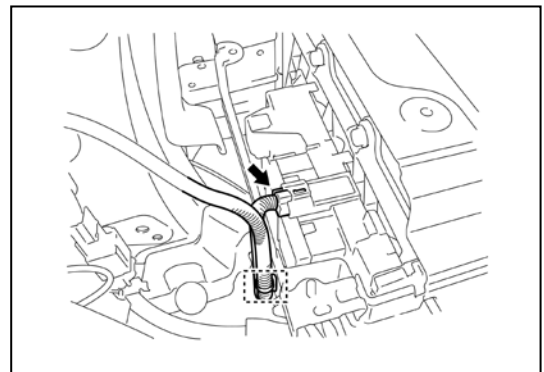

- (2) Disconnect the 2 connectors.

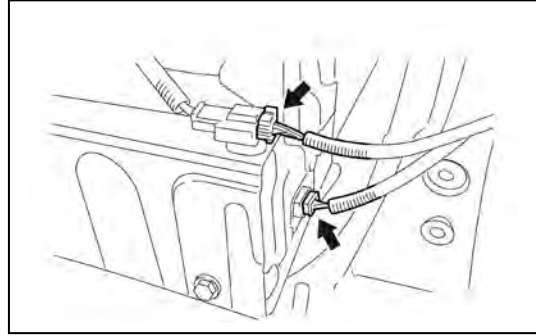

32. REMOVE HV BATTERY

Caution:

Wear insulated gloves.

Notice:

Since the HV battery is very heavy, 2 people are needed to remove the HV battery.

When removing the HV battery, do not damage the parts around it.

- (1) Remove the 6 bolts from the HV battery.

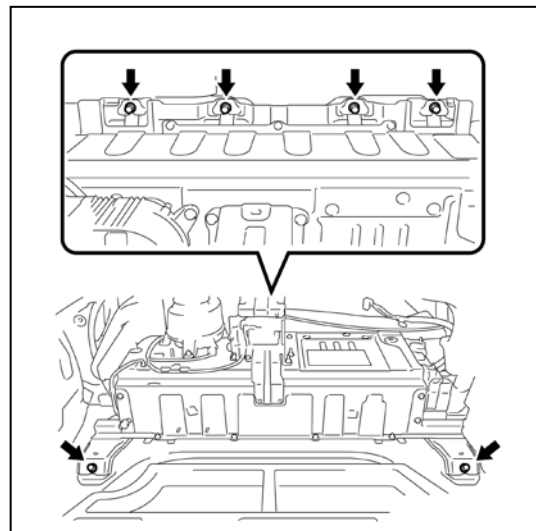

- (2) Pull the HV battery toward the center of the luggage compartment.

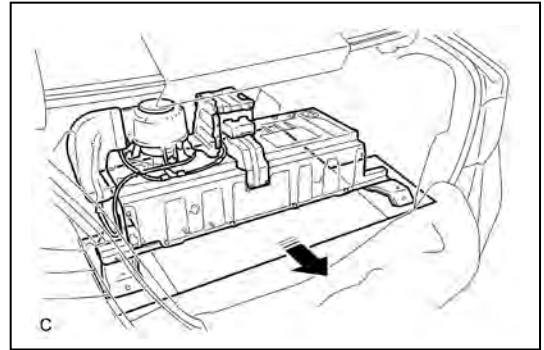

- (3) Remove the 2 nuts and No. 2 hybrid vehicle battery upper cover bracket.

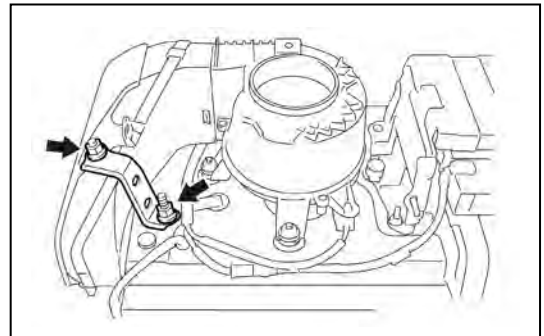

- (4) Remove the clip.
(5) Disengage the 2 claws and remove the No. 2 hybrid battery intake duct.

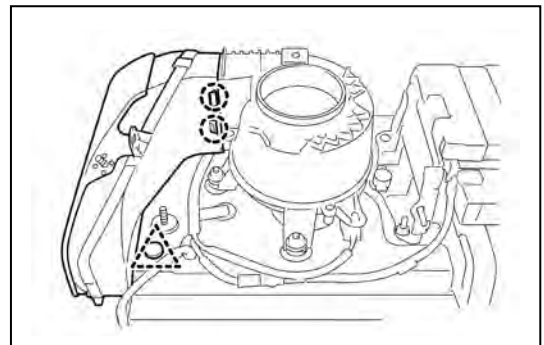

- (6) Disconnect the connector from the battery cooling blower assembly.
(7) Remove the 3 nuts and battery cooling blower assembly.

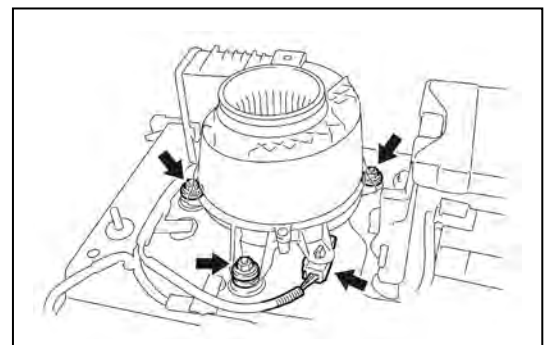

- (8) Turn the HV battery 180° .
(9) Pull the HV battery together with the cardboard toward the rear of the vehicle.

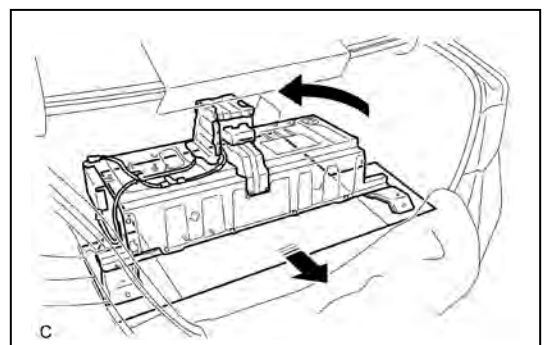

(10) Using a suitable adaptor such as a rope, remove the HV battery while tilting the HV battery.

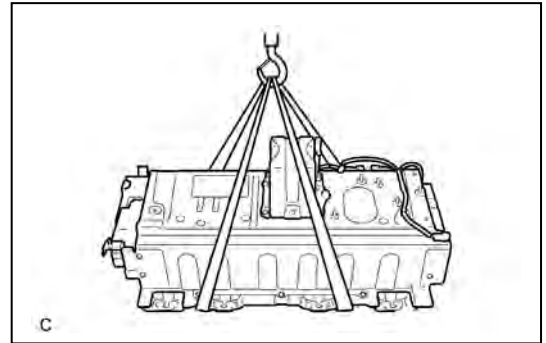









34. The HV battery pack is recyclable. Contact your Toyota distributor (if included on the HV battery caution label) or contact the nearest Toyota dealer (see the next 2 pages for samples of the HV battery caution label).

Caution:

After removing the HV battery, do not reinstall the service plug grip to the HV battery.

HV Battery Caution Label

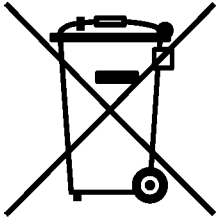
| | | | |
|---|--|--|----------|
|  DANGER | |        | |
| High Voltage Inside / Alkaline Electrolyte Haute tension à l'intérieur / Electrolyte alcalin | | Ni-MH | |
| <p>Observe the following precautions when you handle this battery unit. If you do not conform to those, it may result in a fire, an electrical shock and death in the worst case. Leakage of alkaline electrolyte may cause blindness or skin problems, if alkaline electrolyte comes into contact with your eyes, skins or clothes. In event of accident, flush with water and get medical help immediately.</p> <p>● Never disassemble, convert or divert this battery unit or remove its covers. (Please have the battery serviced by your dealer or a Qualified Technician.) ● Do not dump this unit illegally. It may result in pollution, death or serious injury. ● Do not puncture or expose this unit to impact. ● Keep this unit away from a fire. ● Do not water this unit. ● Keep children away from this unit.</p> <p>Respecter les mesures de précaution suivantes lorsque vous manipulez cette batterie. Le non-respect de ces mesures peut provoquer un incendie ou une décharge électrique et entraîner la mort dans les cas les plus graves. Une fuite d'électrolyte alcalin peut entraîner la cécité ou des problèmes dermatologiques si l'électrolyte alcalin entre en contact avec les yeux, la peau ou les vêtements. En cas d'accident, rincer abondamment à l'eau et consulter immédiatement un médecin.</p> <p>● Ne jamais démonter, convertir ou dévier cette batterie, ou en déposer les couvercles. (Veillez à faire entretenir la batterie par votre concessionnaire ou un technicien qualifié.) ● Ne pas jeter cette batterie de manière illégale. Cela pourrait polluer l'environnement, provoquer de graves blessures ou entraîner la mort. ● Ne pas percer cette batterie ou l'exposer à des impacts. ● Tenir cette batterie éloignée du feu. ● Ne pas mouiller cette batterie. ● Garder hors de portée des enfants.</p> | | | |
|  | | To Qualified Technicians, Haulers, Dismantlers A l'attention des techniciens qualifiés, transporteurs, démonteurs | |
| <p>Be sure to read the Repair Manual when servicing or replacing this unit. Please consult your dealer or your national distributor when hauling or dismantling this unit. Veillez à lire le manuel de réparation lors de l'entretien ou du remplacement de cette batterie. Veillez à consulter votre concessionnaire ou votre distributeur national lorsque vous transportez ou démontez cette batterie.</p> | | | |
| HV Battery Recycling Information Informations concernant le recyclage des batteries des HV (Véhicules Hybrides): | | | |
| <p>● Please transport this unit in accordance with all applicable laws. ● Consultations about replacing and disposing this battery unit are accepted in your dealer or your national distributor. ● Veillez à transporter cette batterie dans le respect des lois applicables. ● Vous pouvez consulter votre concessionnaire ou votre distributeur national pour savoir comment remplacer ou éliminer cette batterie.</p> | | | |
| | | | D |

Product Safety Data Sheet

This product (a battery) is an "Article" pursuant to 29 CFR 1910.1200 and, as such, is not subject to the OSHA Hazard Communication Standard requirements for preparation of a Material Safety Data Sheets, (MSDS).
 This Product Safety Data Sheet is prepared only to provide information to our customers.

1. PRODUCT AND COMPANY IDENTIFICATION

| | | |
|-----|------------------------------|--|
| 1.1 | Product name | Nickel Metal Hydride Battery (Module) |
| 1.2 | Applicable models | EV-MH type EV-MP095R15A (EV-95) EV-MP6R5R01 (GEN I) EV-MP6R5R02 (GEN II) EV-MP6R5R03 (GEN 2.5 8cells module type) EV-MP6R5R27 (GEN 2.5 12cells module type) EV-MP6R5R47 (GEN 2.5L 12cells module type) |
| 1.3 | Product use | Hybrid Vehicle Battery |
| 1.4 | Name of manufacturer | Primearth EV Energy Co., Ltd. |
| 1.5 | Address of manufacturer | 20,Okasaki,Kosai-City,Shizuoka, 431-0422 Japan |
| 1.6 | Phone number of manufacturer | +81-53-577-3592 (Japan) |
| 1.7 | Post in charge | Enginnering Dept. |
| 1.8 | Name of person in charge | Osamu Takahashi |
| 1.9 | Issue number | P0251 |

2. HAZARD IDENTIFICATION

This product is not dangerous as long as it is used for prescribed purposes and in accordance with its designated usage. As the product is a storage device for electricity, it may give the user an electric shock. It has no adverse effect on human health or the environment unless the pack and cell casings are breached.

| | | |
|-----|------------------------------|--|
| 2.1 | Physical and chemical hazard | This product does not constitute a physical and chemical hazard as long as it is used for prescribed purposes and in accordance with its designated usage. The alkaline electrolyte or materials in the battery may be dangerous if they leak out of the casing due to dismantling or breaching of the battery. This product may cause electric shock, fire, or injury if it is used for purposes other than those prescribed or without following the designated usage. |
| 2.2 | Hazard to human health | This product is not hazardous to human health in normal use. However, if the product dismantle or is breached, the alkaline electrolyte or materials that may leak out of the outer casing may adversely affect human health. This product contains both nickel compounds and cobalt, which are classified as carcinogens by IARC and NTP. |
| 2.3 | Hazard to environment | This product is not hazardous to the environment as long as it is used for prescribed purposes and in accordance with its designated usage. However, the contents of the product may have an adverse effect on the environment in the event of their leakage from the casing due to dismantling or |

3. COMPOSITION & INGREDIENT INFORMATION

| Chemical name | Chemical symbol | CAS. No. | Exposure limits in air | |
|----------------------------------|-----------------|------------|------------------------|----------|
| | | | ACGIH | OSHA |
| Positive electrode, composed of: | | | | |
| •Nickel hydroxide | Ni(OH)2 | 12054-48-7 | 0.2mg/m3 | 1mg/m3 |
| •Nickel | Ni | 7440-02-0 | 0.2mg/m3 | 1mg/m3 |
| •Cobalt | Co | 7440-48-4 | 0.02mg/m3 | 0.1mg/m3 |
| Negative electrode, composed of: | | | | |
| •Hydrogen absorbing alloy | *1 | | | |
| •Iron | Fe | 7439-89-6 | NA | NA |
| Alkaline electrolyte | *2 | | | |

*1: Main contents contained in hydrogen absorbing alloy
 Nickel(Ni)-CAS#7440-02-0, Cobalt(Co)-CAS#7440-48-4, Manganese (Mn)-CAS#7439-96-5,
 Aluminum (Al)-CAS#7429-90-5, Rare earths [Lanthanum (La)-CAS#7439-91-0, Cerium (Ce)-CAS#7440-45-1,
 Neodymium (Nd)-CAS#7440-00-8, Praseodymium (Pr)-CAS#7440-10-0]

*2: Main contents contained in alkaline electrolyte
 Potassium hydroxide (KOH)-CAS#1310-58-3, Sodium hydroxide (NaOH)-CAS#1310-73-2,
 Lithium hydroxide (LiOH)-CAS#1310-65-2

4. FIRST AID MEASURES

In the event of the leakage of electrolyte or gassing of the battery, take the appropriate first aid measures from the following.

| | | |
|-----|--------------|--|
| 4.1 | Eye contact | Contact may cause corneal injury and blindness. Wash eyes with large amounts of running water for at least 15 minutes. Seek medical treatment immediately. If appropriate actions are not taken, eye disorders may result. |
| 4.2 | Skin contact | Wash the contact area with plenty of water. Seek medical treatment immediately. Clothing, shoes, and socks, etc. which have come into contact with alkaline electrolyte should be taken off immediately. If appropriate actions are not taken, skin inflammation may occur. |
| 4.3 | Inhalation | Move the exposed person to fresh air area immediately. Cover up the affected person with a blanket. Seek medical treatment immediately. |
| 4.4 | Ingestion | Do not induce vomiting . Seek medical treatment immediately. |

5. FIREFIGHTING MEASURES

In the event of a battery fire, take the following measures.

| | | |
|-----|---|---|
| 5.1 | Extinguishing media and method | (1) Use a dry powder acrylonitrile butadiene styrene (ABS) fire extinguisher for fire-fighting. (2)Extinguishing a fire with a large amount of water may be an effective method . However, this should be considered as a supplementary means If there are no readily available large amounts of water, use dry sand instead; as the application of only a small amount of water may temporarily act as an accelerant and affect the fire adversely while the hydrogen storage alloy is burning. |
| 5.2 | Exposure controls and personal protection for fire-fighting | Use air-breathing apparatus as noxious fumes may be produced. |
| 5.3 | Fire spread prevention | (1) In the case of fire, remove surrounding inflammables immediately. (2) In the case of fire in peripheral devices, move the battery to a safe place immediately. |

6. ACCIDENTAL RELEASE MEASURES

Take the following measures if the alkaline electrolyte has leaked out of the battery.

| | | |
|-----|--|---|
| 6.1 | | Wipe up the alkaline electrolyte with a cloth. Dispose of the cloth used to wipe up the electrolyte in accordance with applicable laws and regulations. |
|-----|--|---|

7. HANDLING & STORAGE INFORMATION

Observe the following cautions and prohibited items. Handle the battery carefully.

| | | |
|-----|------------------|--|
| 7.1 | Prohibited items | (1) Short-circuiting Short-circuiting may cause burn injury due to ignition or heating effect. (2) Dismantle or modification Alkaline electrolyte leaks when the battery (cell) is disassembled. (3) Overcharging or over-discharging Oxygen or hydrogen may be produced when the battery is overcharged or over-discharged. (4) Use in an airtight container The container may explode due to the gas produced from the battery. |
|-----|------------------|--|

| | | |
|---|---------------------------------------|---|
| 7.2 | Cautions | (1) Do not stack a battery on another battery. (2) Do not store batteries on electrically conductive surfaces such as metals. (3) Wear protective glasses and rubber gloves while handling batteries. |
| 8. EXPOSURE CONTROLS & PERSONAL PROTECTION | | |
| Take the following measures in the event of leakage of the alkaline electrolyte or alkaline mixed gas from the battery. | | |
| 8.1 | Facilities | (1) Store the product in a depository with local exhaust systems for ventilation. (2) Install an exhaust system or exhaust port when the product is used in a container. |
| 8.2 | Protective equipment | Wear protective glasses, protective gloves, and simple filter mask. |
| 9. PHYSICAL & CHEMICAL PROPERTIES | | |
| 9.1 | Physical state | Solid |
| 9.2 | Order | No order |
| 9.3 | pH | Not applicable (ELECTROLYTE : >12) |
| 9.4 | Freezing point | Not applicable |
| 9.5 | Boiling point | Not applicable (ELECTROLYTE : 100°C; Water) |
| 9.6 | Evaporation rate | Not applicable |
| 9.7 | Vapor pressure | Not applicable |
| 9.8 | Vapor density | Not applicable |
| 9.9 | Solubility (Water) | Not applicable (Electrolyte is soluble.) |
| 10. STABILITY & REACTIVITY | | |
| This product is stable as long as it is used for prescribed purposes and in accordance with its designated usage. However, short-circuiting, overcharging/over-discharging, and long-term storage in a high-temperature environment may lead to the ignition or explosion of the battery. | | |
| 10.1 | Possible causes of fire | Sparks due to short-circuit. A large current is applied to a module or a cell. |
| 10.2 | Possible causes of explosion | The battery will not explode by itself unless the safety valve is frequently activated and the battery is kept in an airtight container, in which case the oxygen and hydrogen produced from the battery may trigger an explosion. |
| 10.3 | Possible causes of fire and explosion | (1) Overcharging or over-discharging (2) The temperature of the battery at 100°C or higher (3) Overcharging or over-discharging of the battery in an airtight container located close to a heat source |
| 11. TOXICOLOGICAL INFORMATION | | |
| This product is not hazardous as long as it is used for prescribed purposes and in accordance with its designated usage. If the battery disintegrates or is breached, the alkaline electrolyte or contents that have leaked out of the casing may adversely affect human health. | | |
| 11.1 | Carcinogenicity | The nickel-plated iron of this product is not harmful as long as it is used for prescribed purposes and in accordance with its designated usage. This product contains both nickel compounds and cobalt, which are classified as carcinogens by the International Agency for Research on Cancer (IARC) and the National Toxicology Program (NTP). |
| 12. ECOLOGICAL INFORMATION | | |
| 12.1 | | This product is not dangerous as long as it is used for prescribed purposes and in accordance with its designated usage. This product is not hazardous to the environment as long as it is used for prescribed purposes and in accordance with its designated usage. However, the contents of the product may have an adverse effect on the environment in the event of their leakage from the casing due to dismantling or breaching of the battery. |
| 13. DISPOSAL CONSIDERATIONS | | |
| 13.1 | | Batteries should be disposed in accordance with designated provisions by vehicle manufacturers or dealers. |

| 14. NOTES IN TRANSPORTATION | | |
|--|---|--|
| Refer to "15. REGULATORY INFORMATION" for applicable laws and regulations. | | |
| 14.1 | Label of contents | The indication of surface of the casing are not subjected any regulations. Refer to "14. REGULATORY INFORMATION" for applicable laws and regulations. |
| 14.2 | No short-circuit | The battery terminals should be designed so that external short-circuiting can be avoided. Make sure the batteries are not short-circuited during the packaging process. |
| 14.3 | No damage and overturn | Use sufficiently strong materials for packaging boxes so that the product is not damaged due to vibration, shocks, falls, stacking, and so on. Pack the product so that the battery does not fall sideways, and is not inverted during transportation. |
| 14.4 | Protection from rain water | Avoid contact with rain or other water during storage and transportation. |
| 14.5 | Protection from fire and high temperatures | Do not place the product close to fire during storage and transportation. Avoid storage in a high-temperature environment. Example: Avoid leaving batteries for disposal in a parked vehicle under the scorching sun. Take sufficient care to avoid prolonged exposure to high temperature. |
| 15. REGULATORY INFORMATION | | |
| 15.1 | Hazardous materials of transportation New Regulations: United Nations, IMDG-Code Enforcement on Jan. 1, 2012 | (1) United Nations (Transport of Dangerous Goods) • UN Number 3496 Classes 9 • Special Provision 117 Subjected to these Regulations only when transport by sea. |
| | | (2) International Air Transport Association (IATA) • Not Registered • Special Provision A123 This entry applies to Batteries, electric storage, not otherwise listed in Subsection 4.2 - List of Dangerous Goods. Examples of such batteries are: alkali-manganese, zinc-carbon, nickel-metal hydride and nickel-cadmium batteries. Any electrical battery or battery powered device, equipment or vehicle having the potential of a dangerous evolution of heat must be prepared for transport so as to prevent (a) a short-circuit (e.g. in the case of batteries, by the effective insulation of exposed terminals; or, in the case of equipment, by disconnection of the battery and protection of exposed terminals); and (b) accidental activation. The words "Not Restricted" and the Special Provision number must be included in the description of the substance on the Air Waybill as required by 8.2.6, when an Air Waybill is issued. |
| | | (3) International Maritime Dangerous Goods Code (IMDG-Code) • UN Number 3496 Classes 9 • Special Provision 117 Only regulated when transported by sea. 963 Nickel-metal hydride button cells or nickel-metal hydride cells or batteries packed with or contained in equipment are not subjected to the provisions of this code. All other nickel-metal hydride cells or batteries shall be securely packed and protected from short circuit. They are subjected to other provisions of this Code provided that they are loaded in a cargo transport unit in a total quantity of less than 100 kg gross mass. When loaded in a cargo transport unit in a total quantity of 100 kg gross mass or more, they are not subjected to other provisions of this Code except those of 5.4.1, 5.4.3 and column (16) of the Dangerous Goods List in chapter 3.2. |

| | | |
|------------------------------|---------------------------|---|
| | | <p>(4) US DOT(Department of Transportation)Title 49 CFR Parts 100-185 Subpart B—Table of Hazardous Materials and Special Provisions § 172.101 Purpose and use of hazardous materials table. Hazardous materials descriptions and proper shipping names * Batteries, nickel-metal hydride see Batteries, dry, sealed, n.o.s. for nickel-metal hydride batteries transported by modes other than vessel * Batteries, dry, sealed, n.o.s. § 172.102 Special provisions. * Transport by modes other than vessel : Special provision 130 * Transport by vessel : Special provision 340</p> <hr/> <p>(5) Japan MLIT (Ministry of Land, Infrastructure, Transport and Tourism) Bulletin 1530 Notice 272 (Dec.22,2010) •UN Number 3496 Classes 9 •Dangerous Goods List Coluum 6(5) SP963 1 Shall be securely packed and protected from short circuit. 2 Tag plate or the name of goods are not required to be displayed. •Dangerous Goods List Coluum 10 SP963 1 Nickel-metal hydride button cells or nickel-metal hydride cells or batteries packed with or contained in equipment are not subjected to the provisions of this notice. 2 All other nickel-metal hydride cells or batteries shall be securely packed and protected from short circuit. They are subjected to other provisions of this notice provided that they are loaded in a cargo transport unit in a total quantity of less than 100 kg gross mass.</p> |
| 16. OTHER INFORMATION | | |
| 16.1 | Cautions | <p>(1)Cautions and prohibited items in this Data Sheet relate to only normal use. Take appropriate safety measures suited for the environment when the product is used for special purposes. (2)This Data Sheet provides only the information of the product, and is not to be taken as a warranty. (3)It is intended for use by persons with technical skills and at their own discretion and risk. (4)The user is responsible for determining that any usage of the data or information in this Data Sheet is in accordance with associated federal, state, and local laws and regulations.</p> |
| 16.2 | Date of creation/revision | November 10, 2011 |