

2011 VE Commodore Sections

Supplied by

Jean-Pierre de Jager and Mark Hickson

Section Profiles

- Through ongoing research and liaison with Holden, ARRO has secured the release of these section profiles of the VE Holden Commodore Sedan
- The section profiles are in key locations where cutters may be applied during extrication techniques, and will assist rescuers to see through the layers, and better understand the complexity and integrity of this vehicle's construction
- This ongoing support from Holden is critical to furthering education for road rescue service providers

Daryl Rush
Research and Education
Australasian Road Rescue Organisation
Phone +61 (0)7 3635 3119
Mobile +61 (0)409 265739
daryl.rush@arro.org.au

2011 VE Commodore Sections

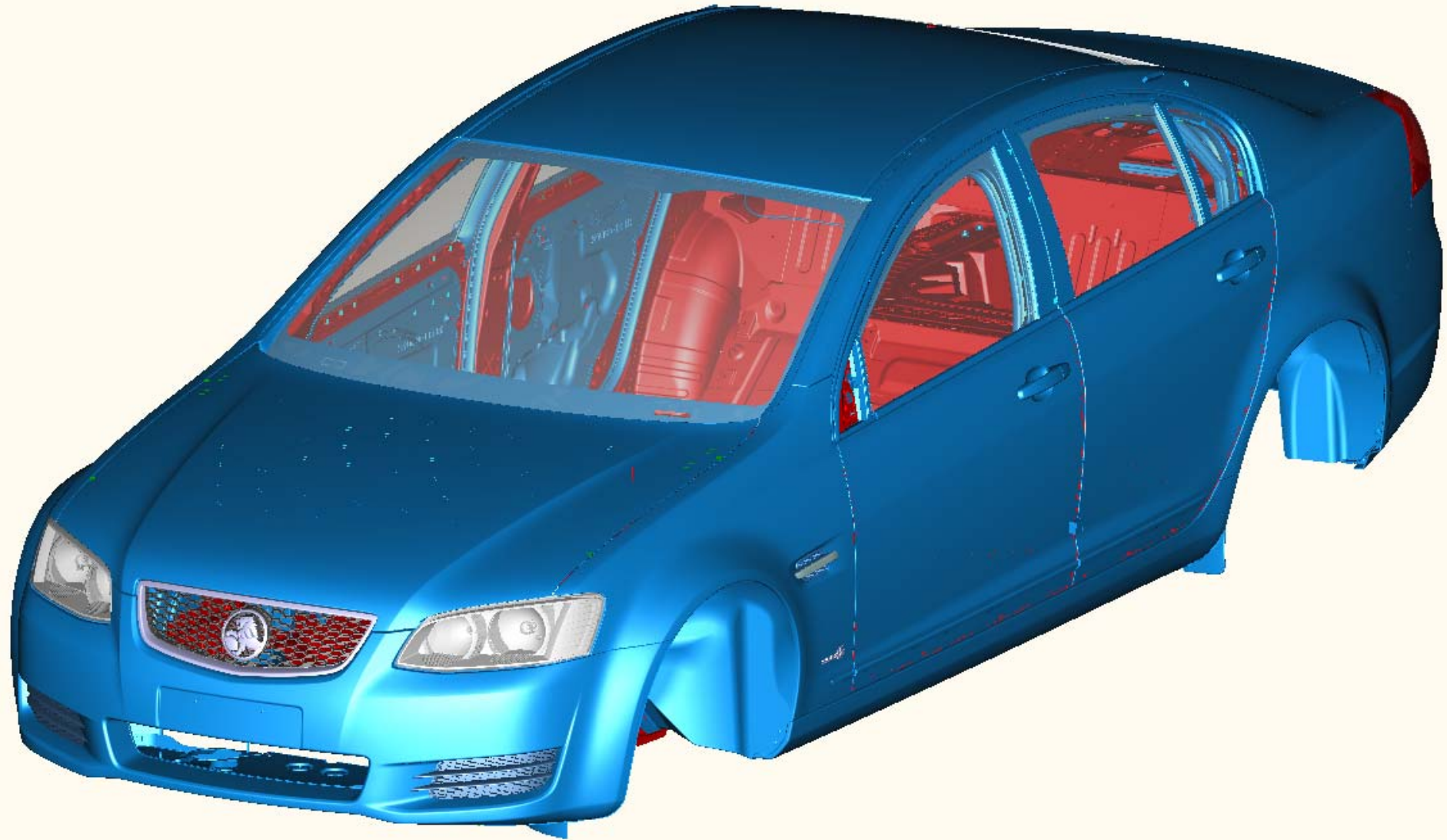

2011 VE Commodore Sections

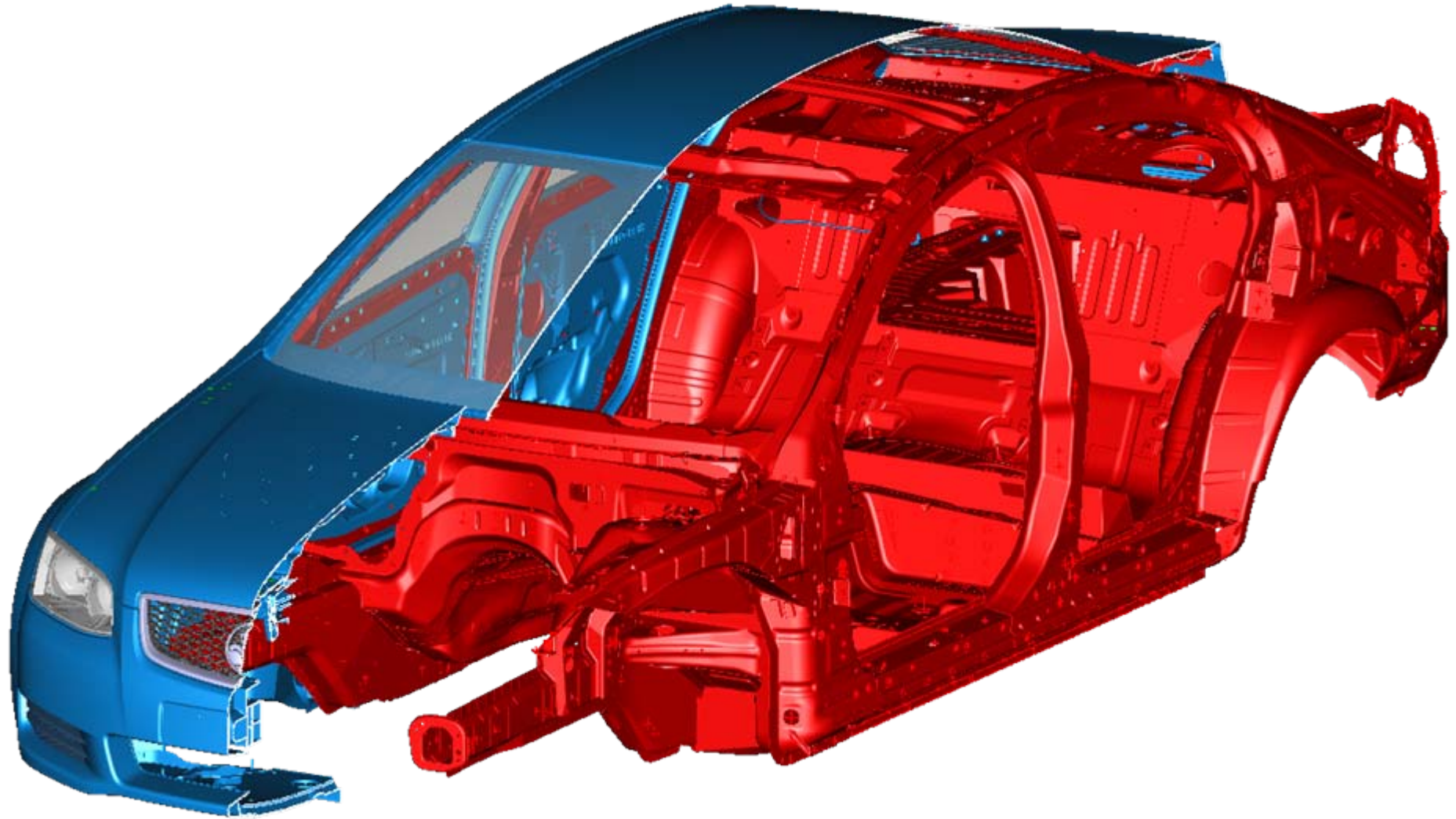

2011 VE Commodore Sections

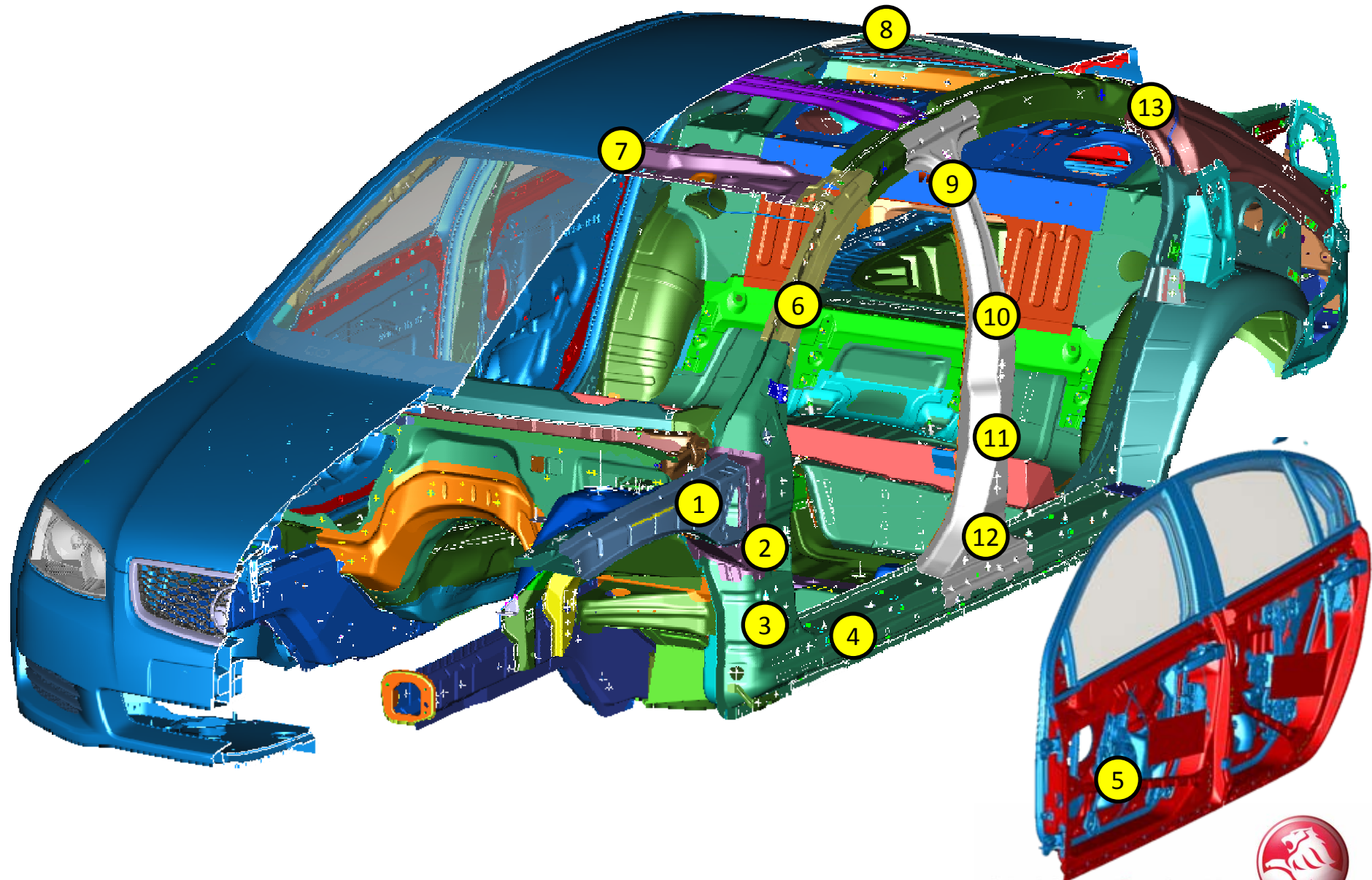

Ultra High Strength Steel

Advanced High Strength Steel

High Strength Steel

Medium Strength Steel

Low Strength Steel

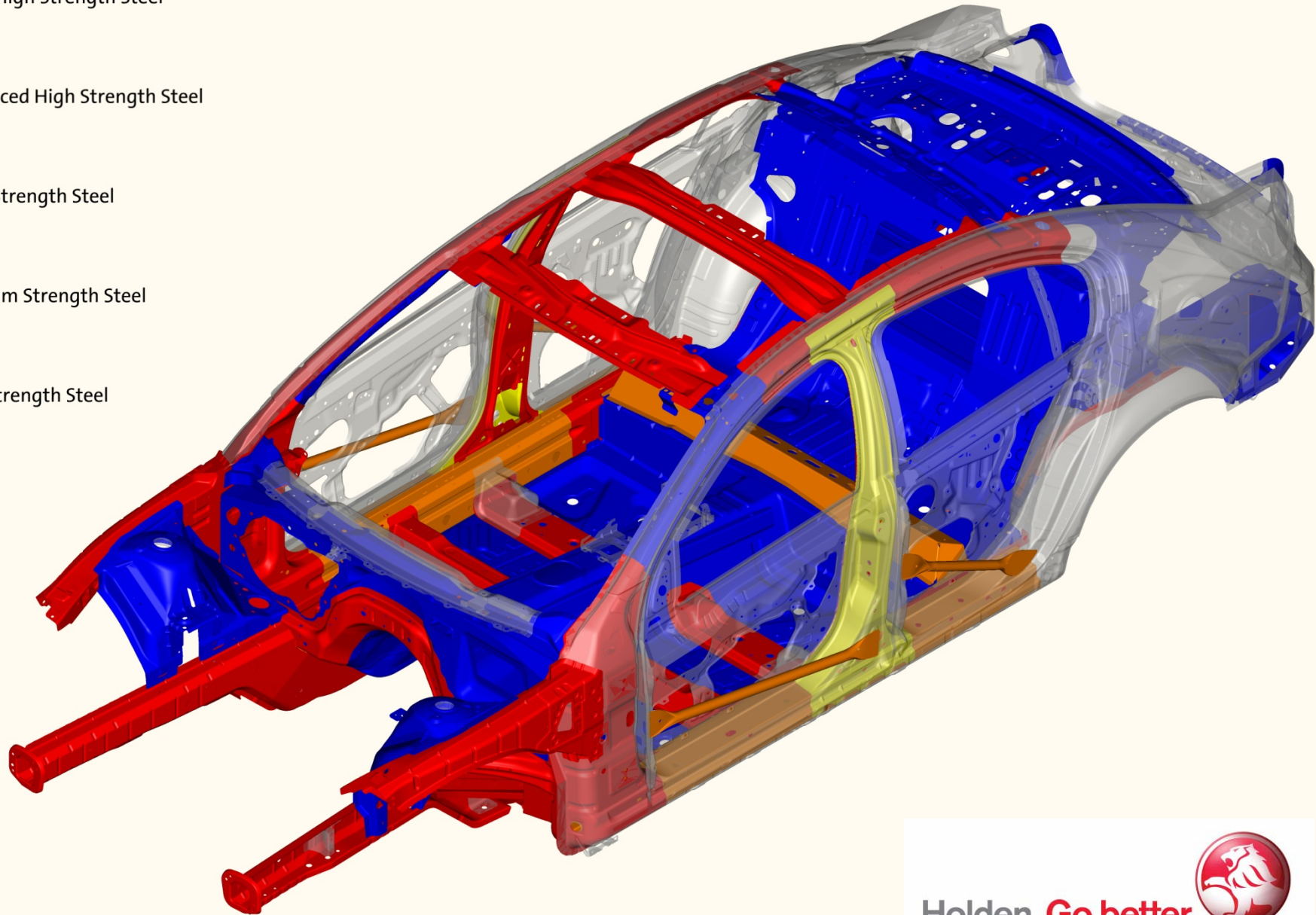

Holden. Go better.



1

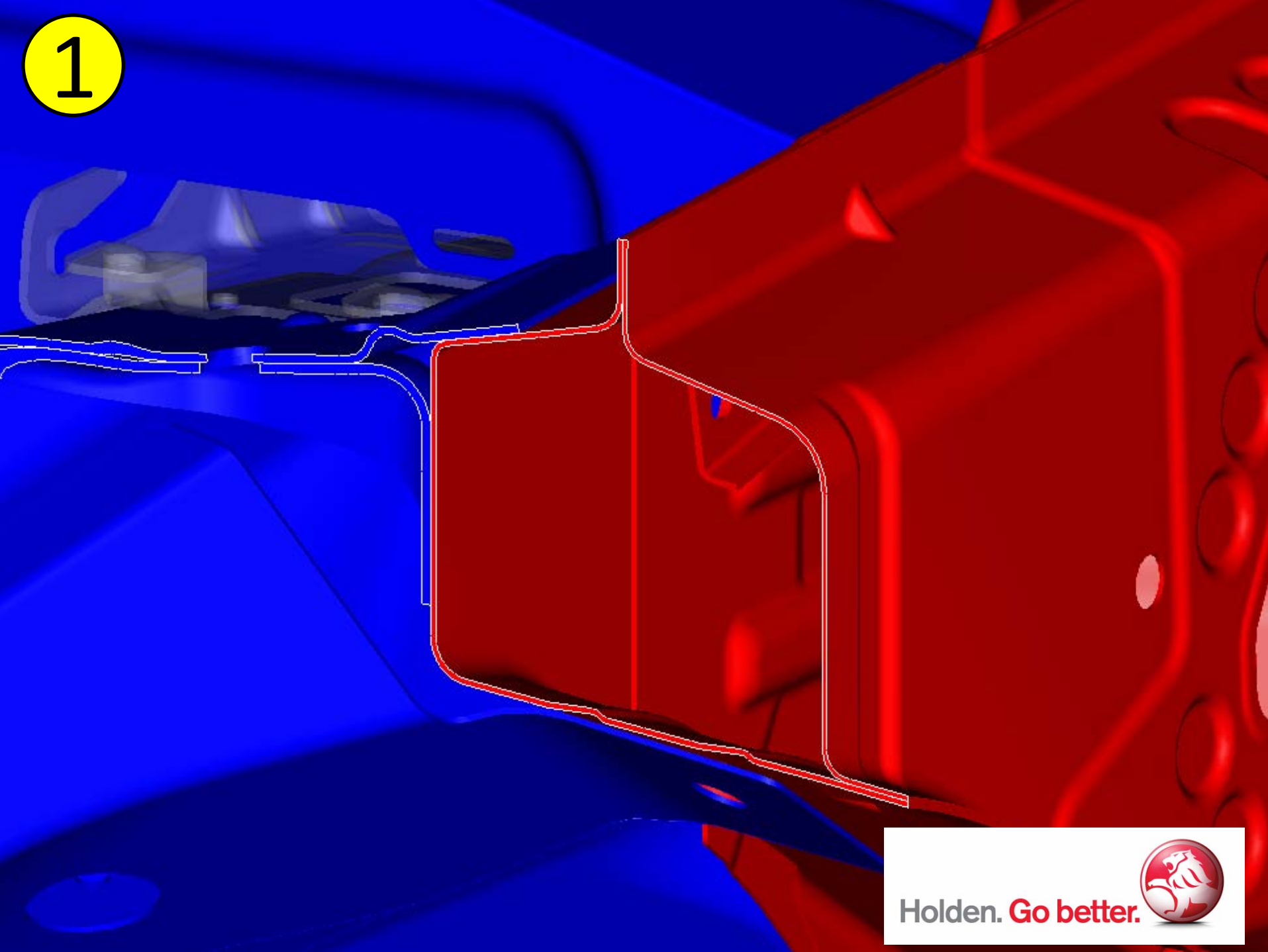

2

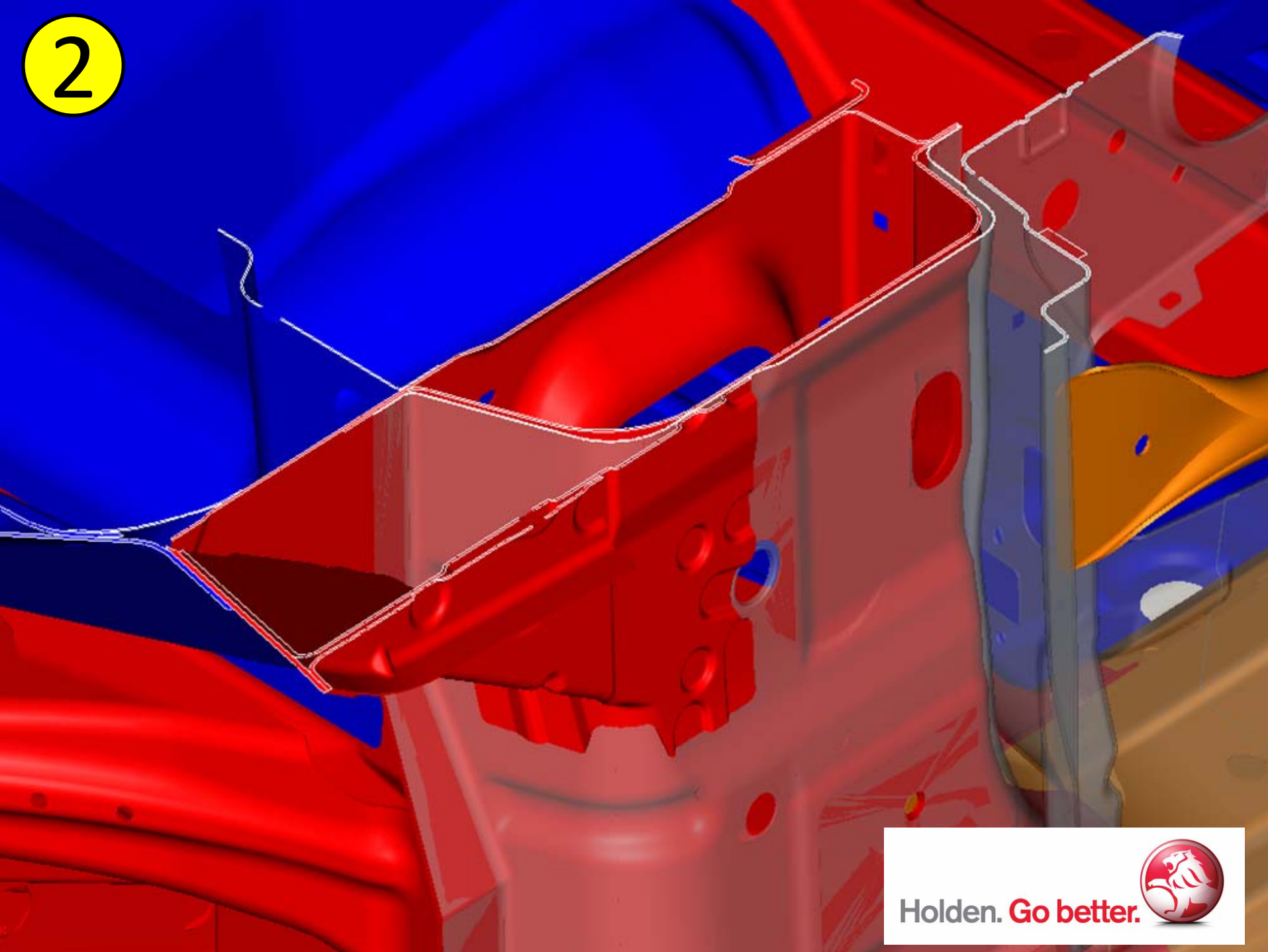

3

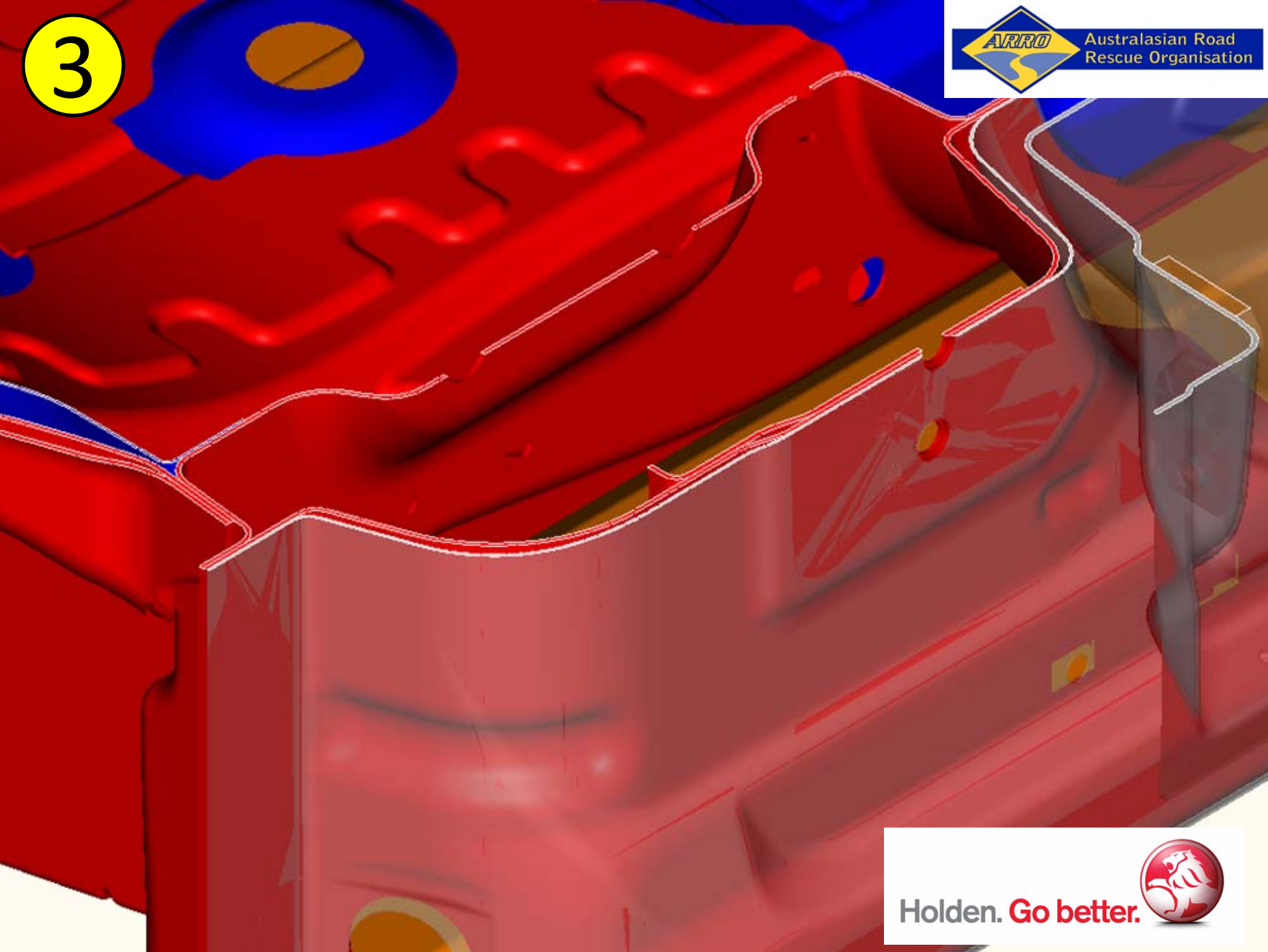

4

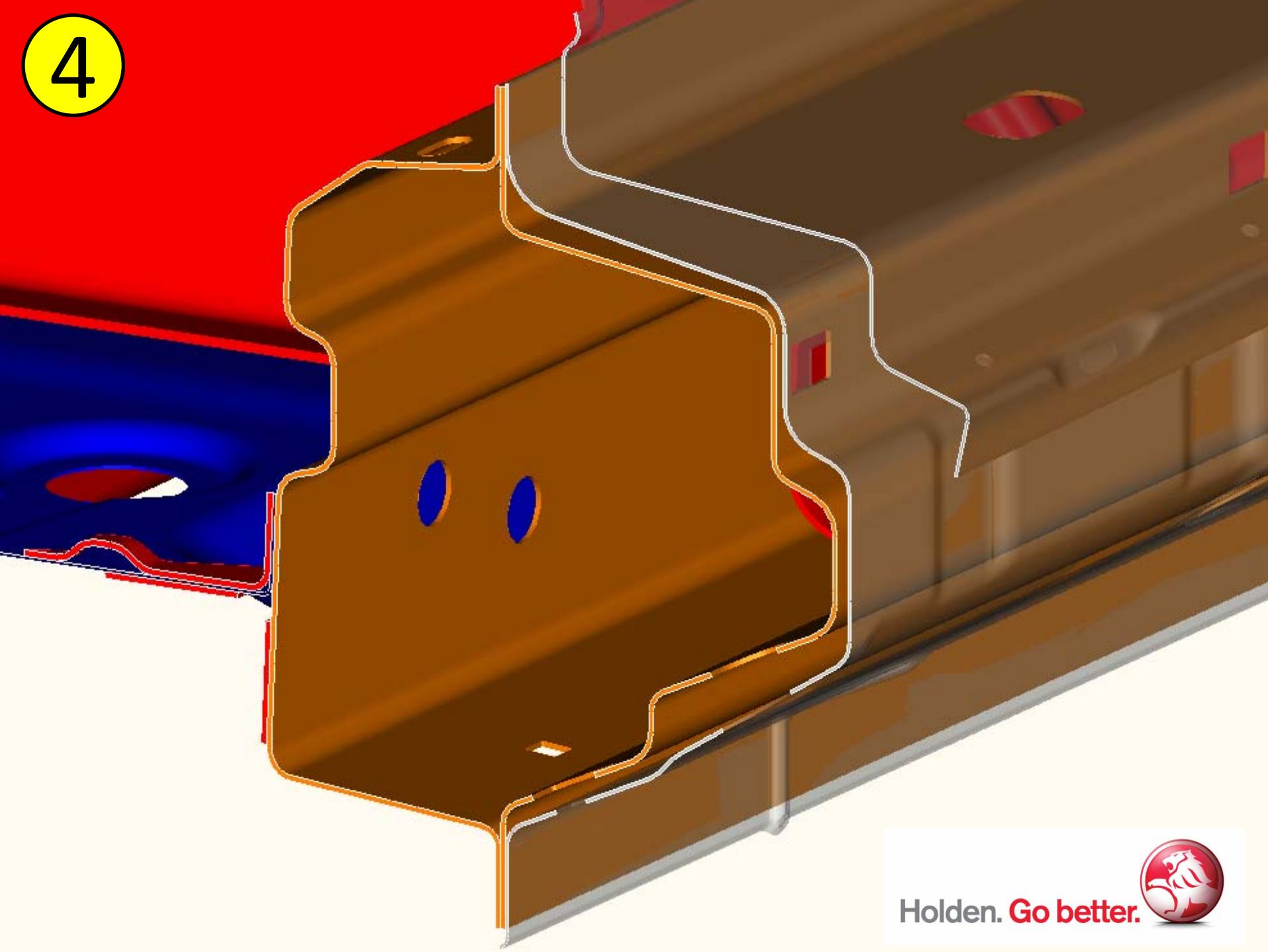

5

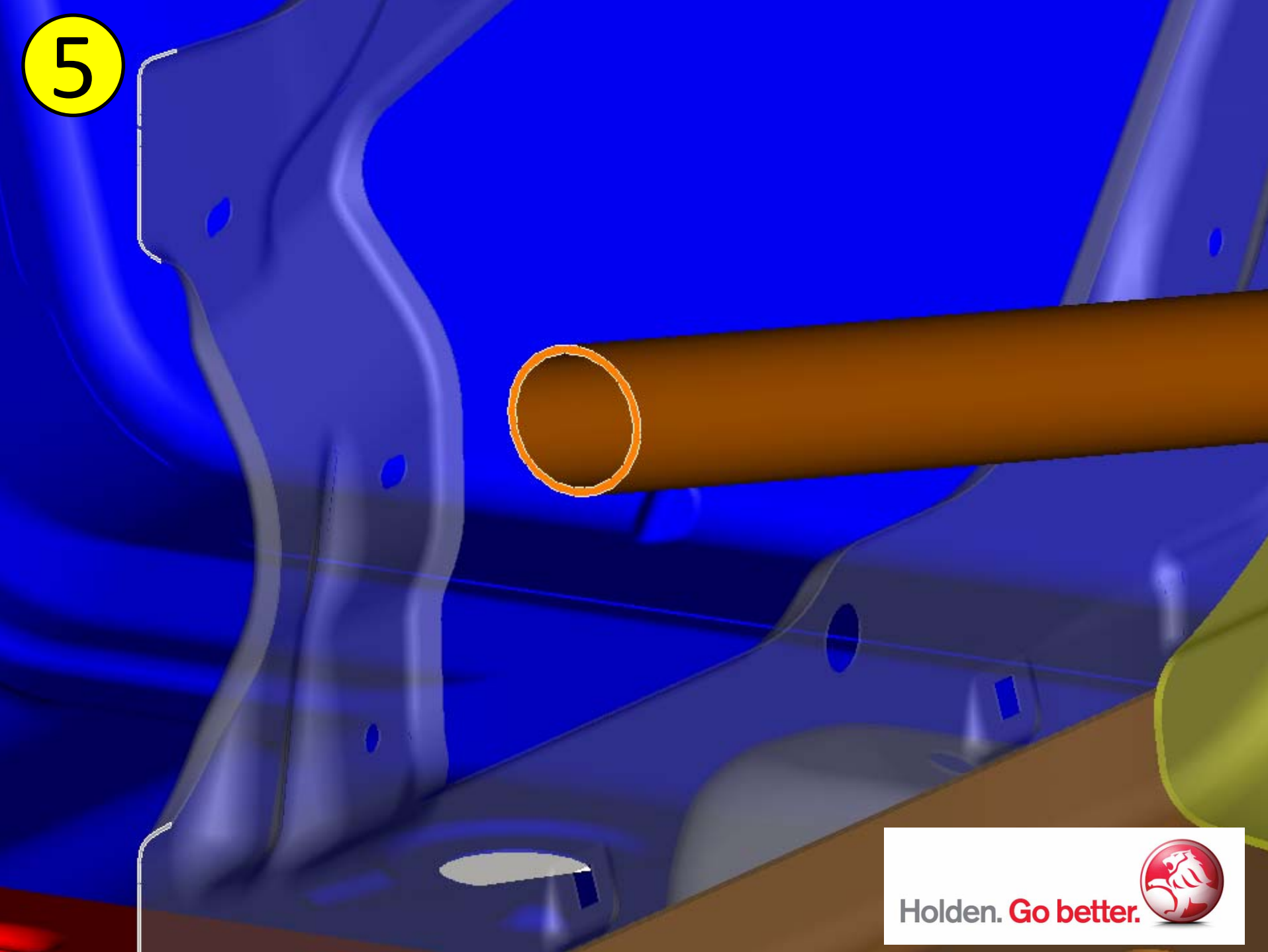

6

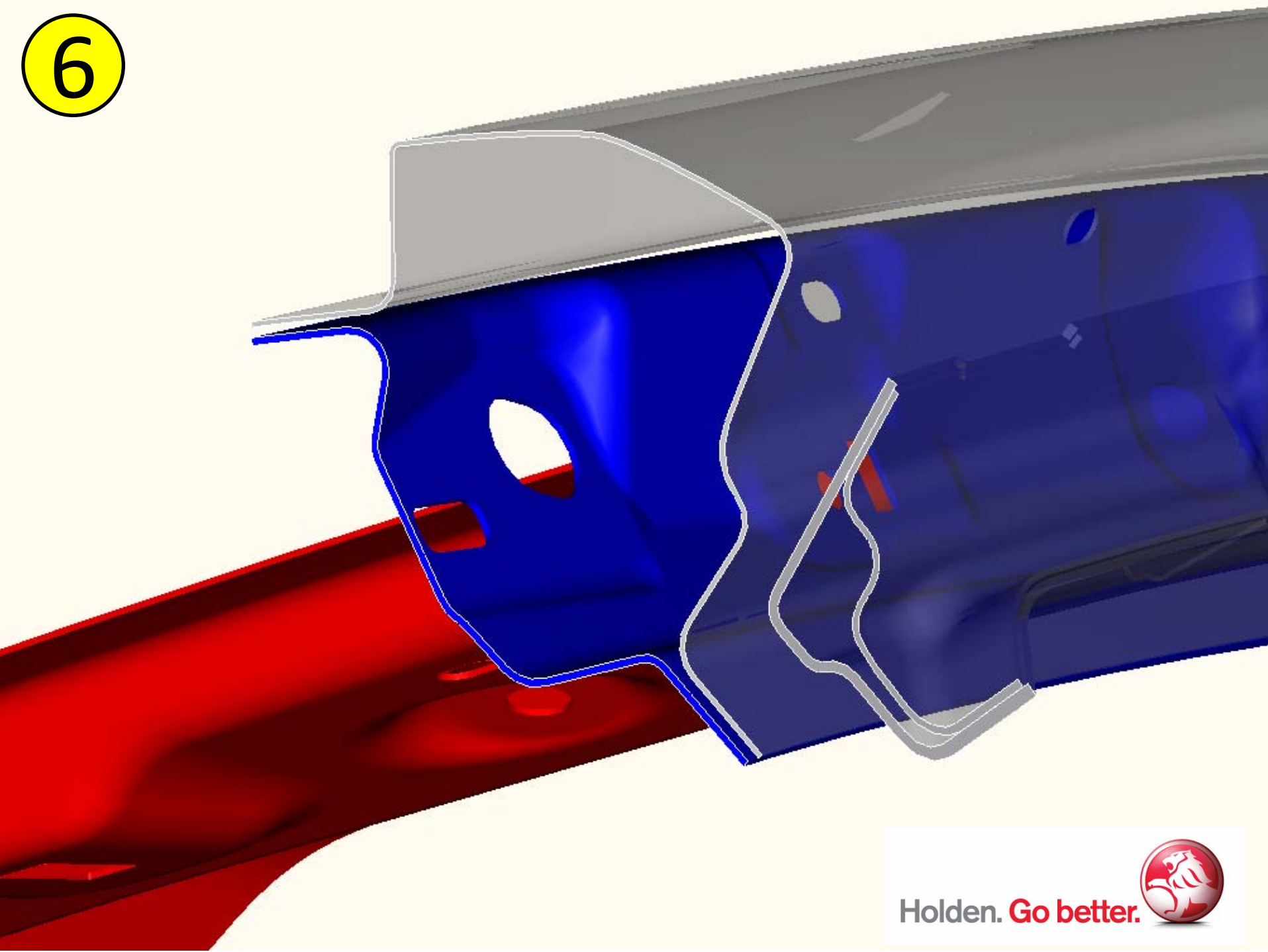

7

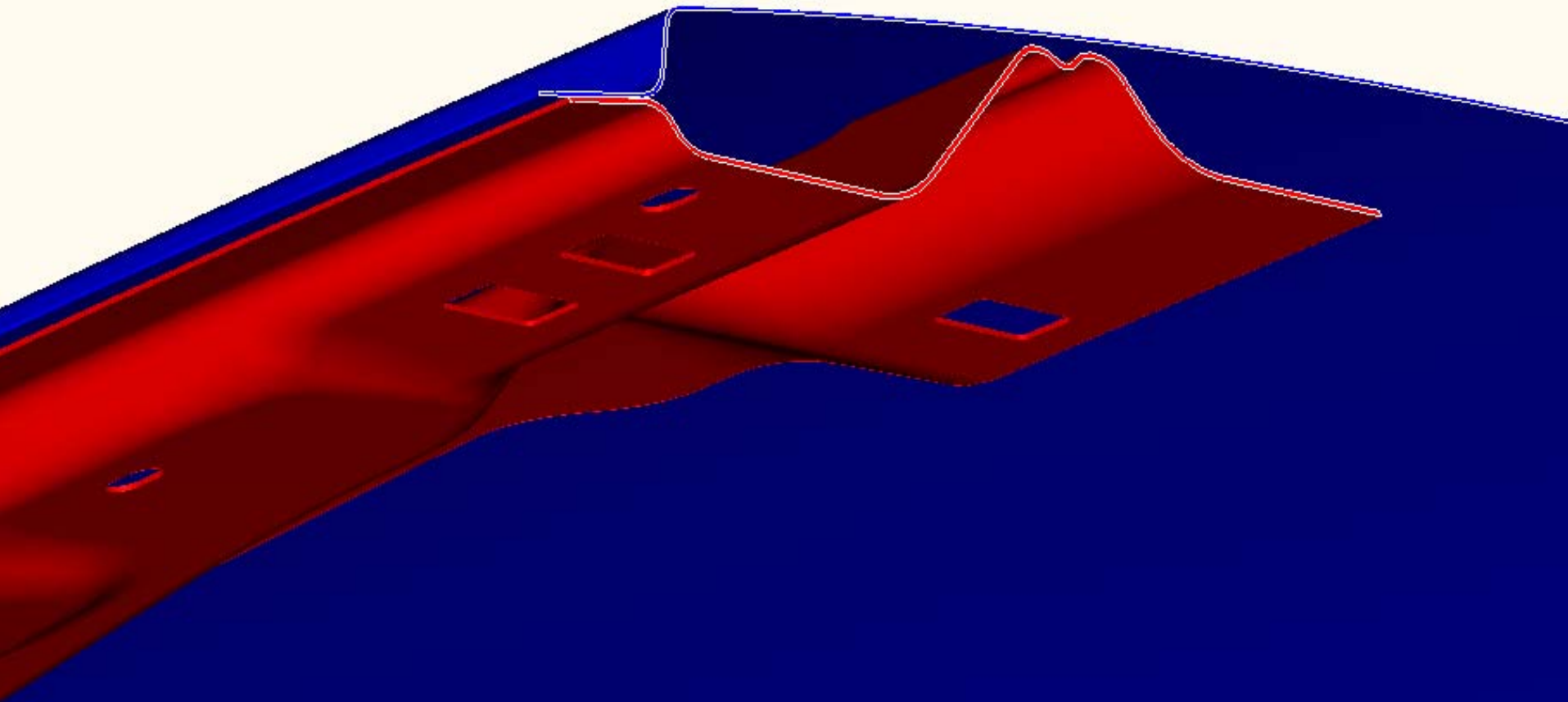

8

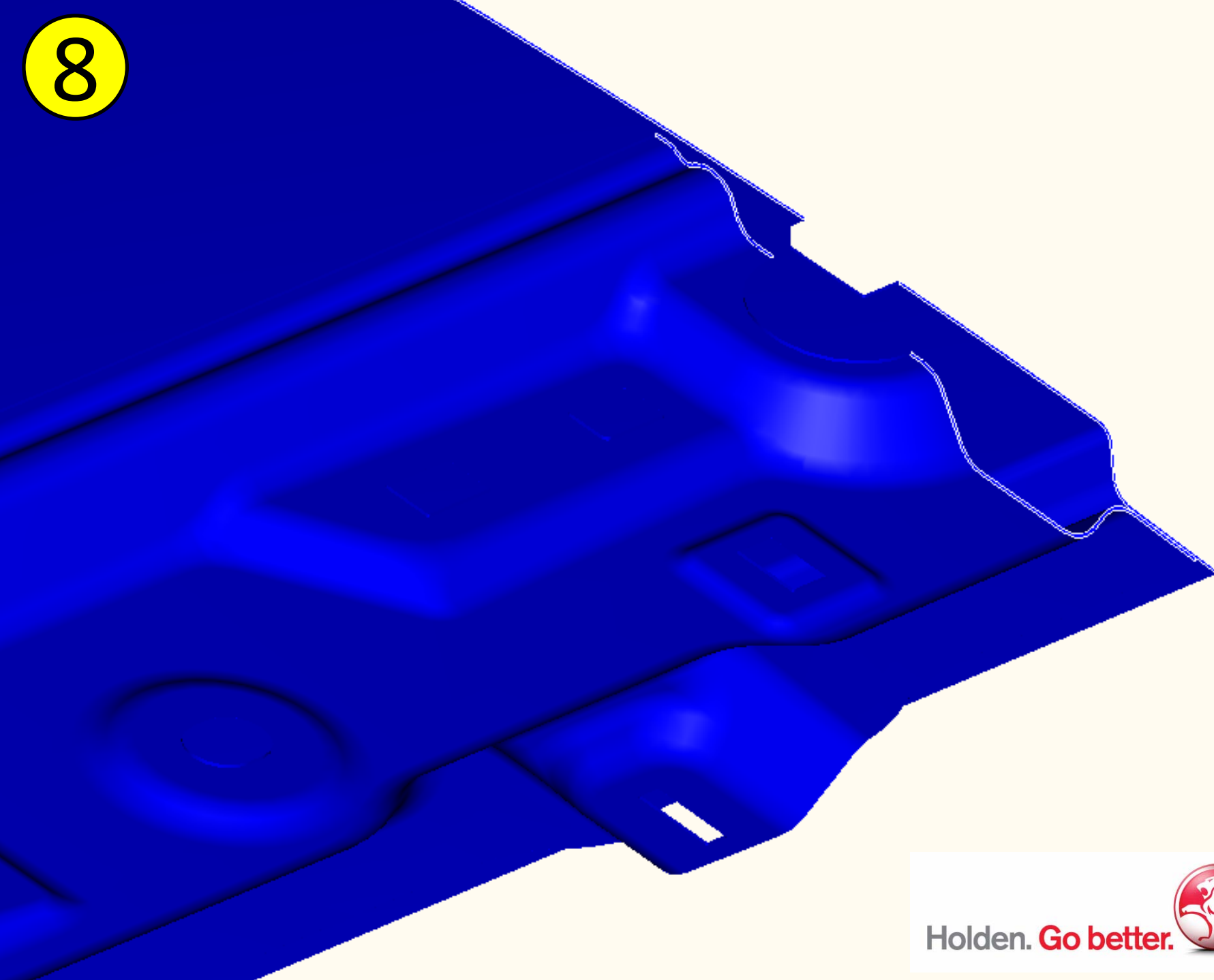

9

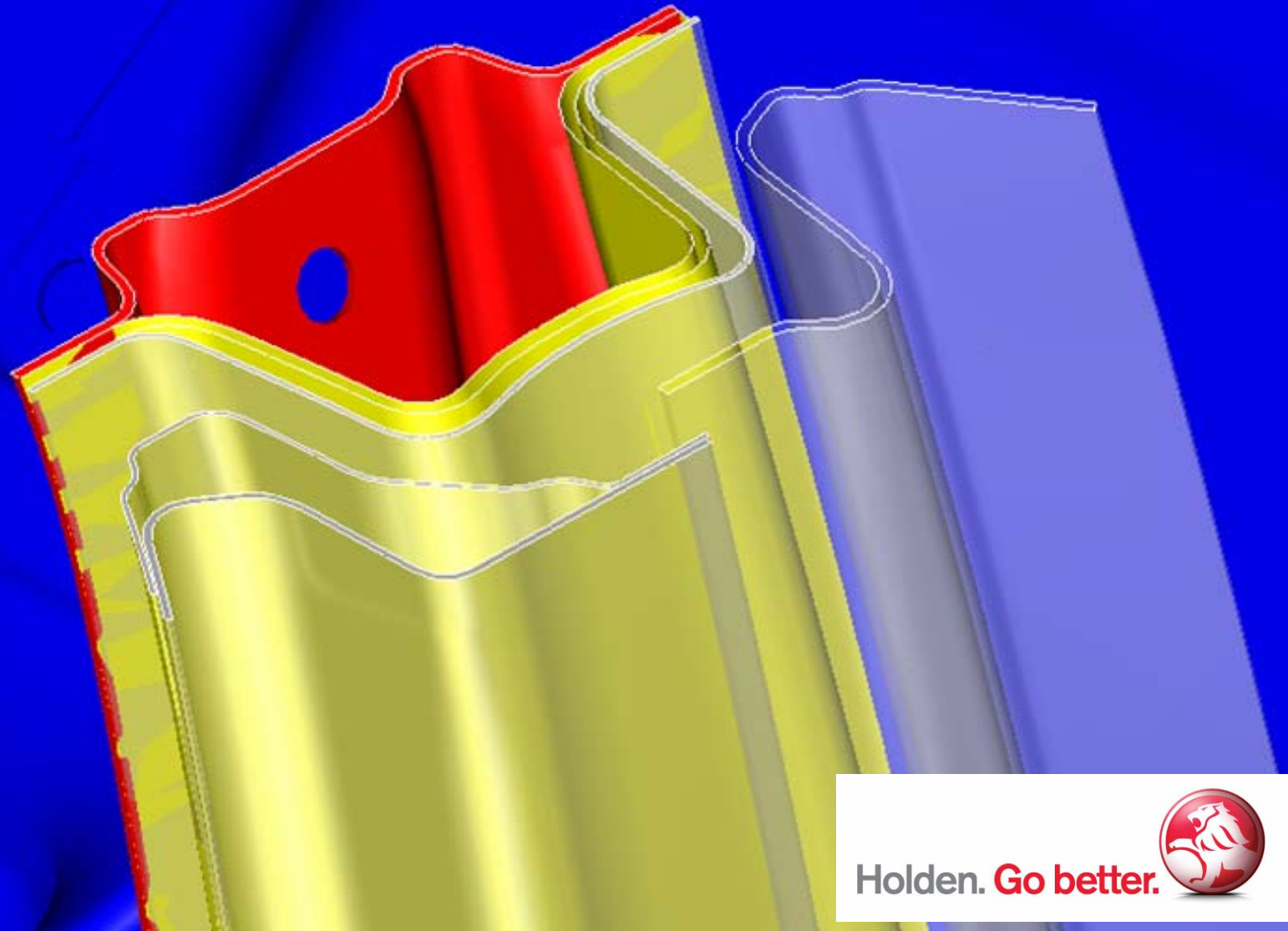

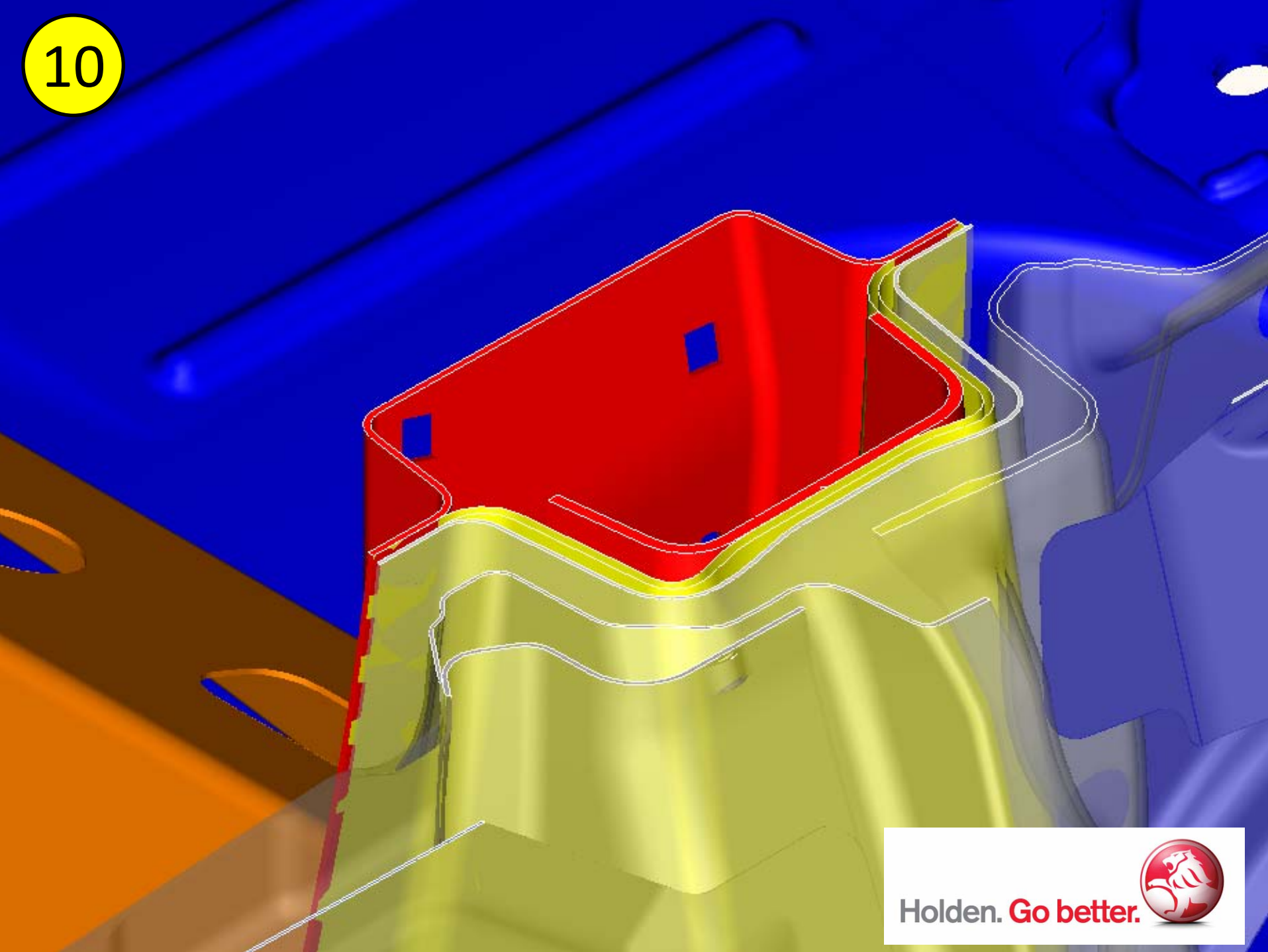

11

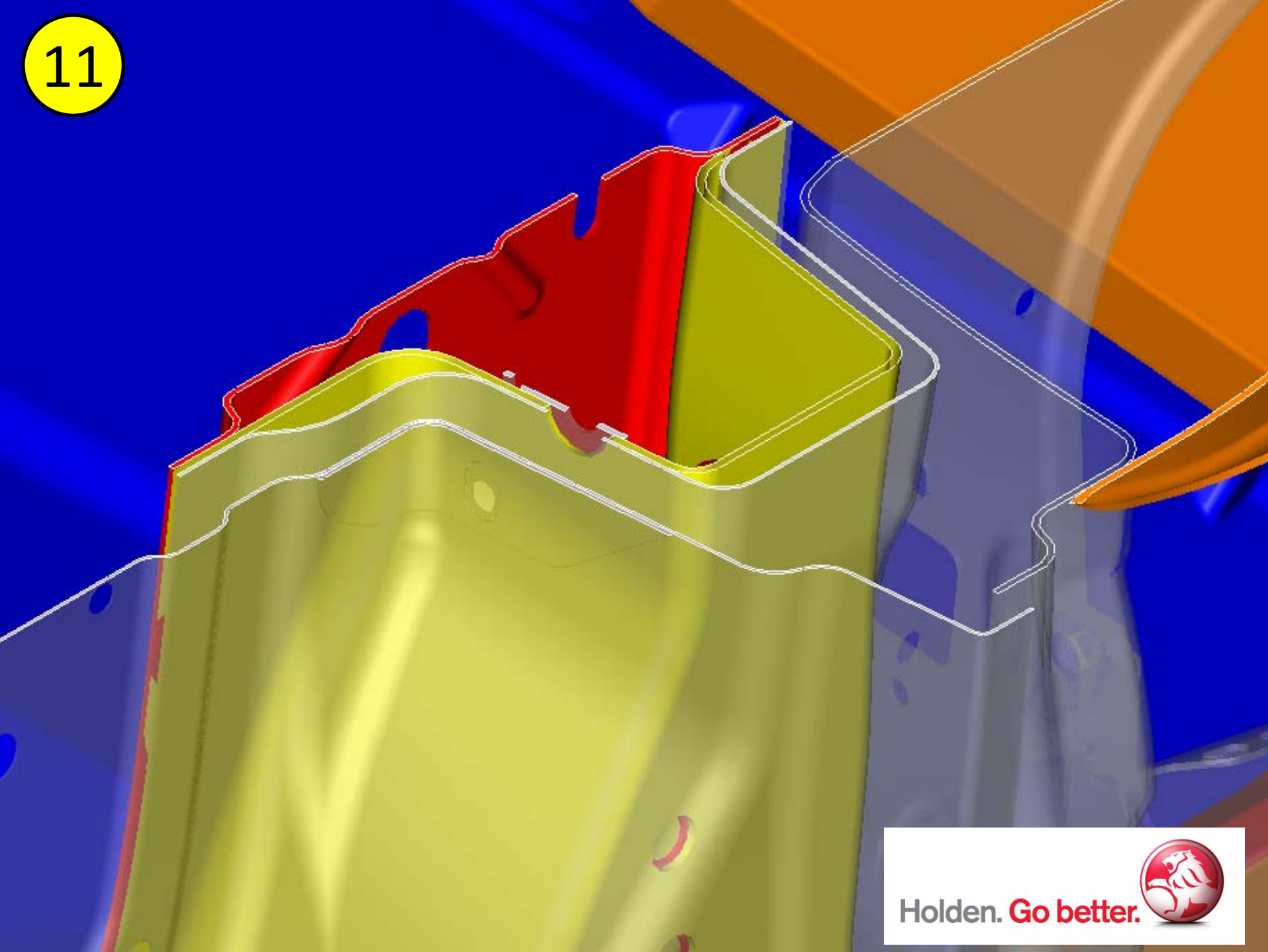

12

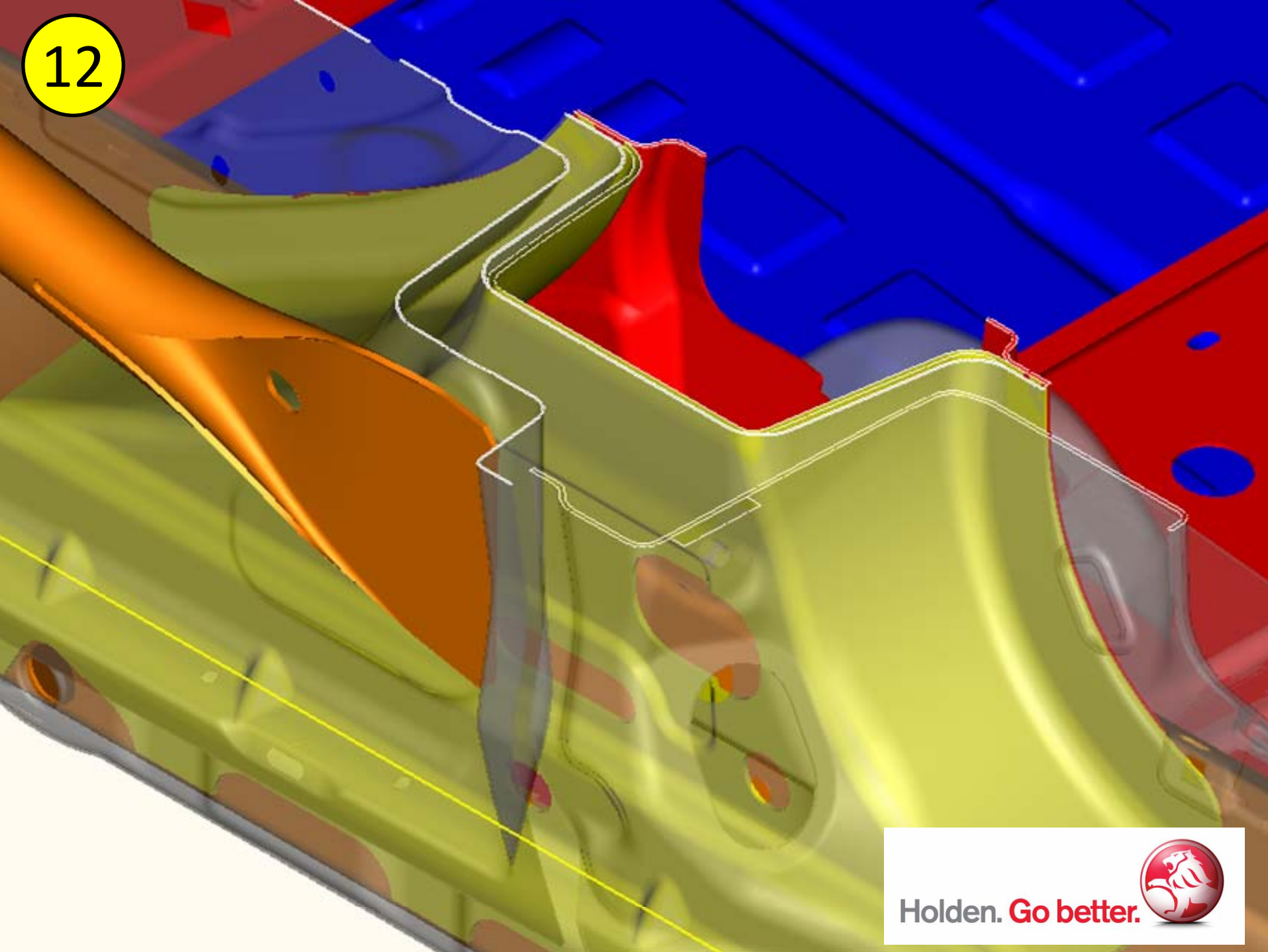

13

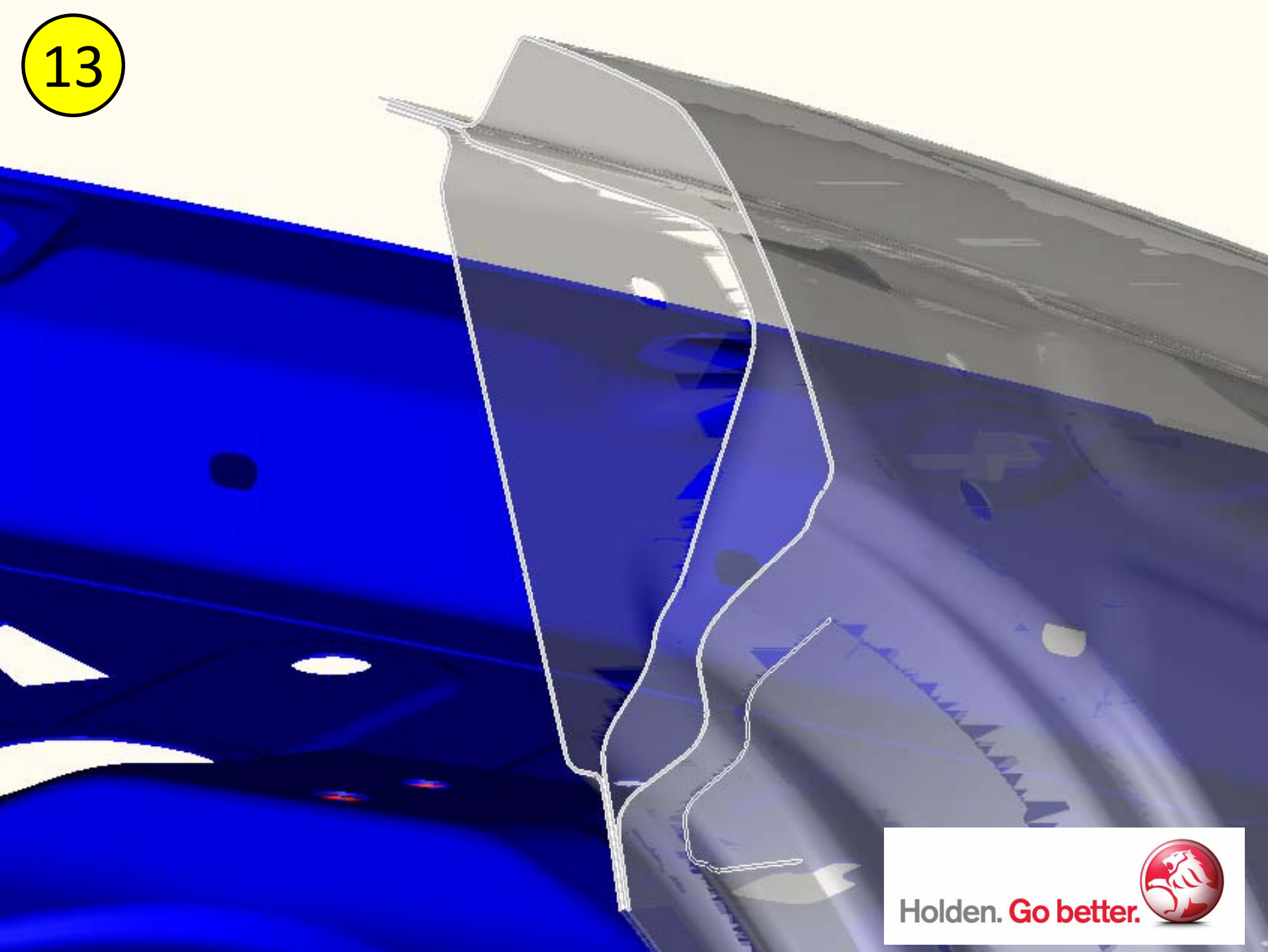

Conclusion

- These section profiles can be used for the familiarisation of rescue personnel and volunteers of the VE Holden Commodore, and in any agency training documentation developed by ARRO member agencies
- If your agency requires this information in a different format, please make contact with ARRO through the Research and Education Officer

Daryl Rush
Research and Education Officer
Australasian Road Rescue Organisation
Phone +61 (0)7 3635 3119
Mobile +61 (0)409 265739
daryl.rush@arro.org.au