

Rescue Manual

Information for Rescue Services

2005



BMW Service
MINI Service

Contents

Introduction	5
Basics	6
Medical aspects	6
Technical aspects	6
Automatic emergency call - "BMW ASSIST"	6
Response of restraint and safety systems after an accident	7
Battery	7
Child restraint systems	7
Use of radio equipment	7
Special protective glass	7
General overview of restraint and safety systems	8
Identification of restraint and safety systems	9
Airbag systems	9
Passenger airbag	
Driver's airbag	
Knee airbag	
Head airbag	
Side airbag	
Safety battery terminal	9
Seat belt tensioner	9
Active head restraints	10
Rollover protection system	10
Series / installation drawings	11
Saloon / Sedan	11
Coupé	19
Compact	21
Touring	26
Convertible	32
SUV - Sports Utility Vehicle	38
MINI	40
Tips for using rescue equipment	42
Jacking vehicles	42
Electric seat adjustment	42
Opening vehicle doors	43
Pressing an instrument panel back	44
Older models	
Newer models	
Securing vehicles	46
Towing eye	
Endless sling	
Chock	
Front and rear axles	

Technical information	47
Airbag	47
Airbag control unit	
Passenger airbag	
Curtain airbag	
Use	
Driver's airbag	
Knee airbag	
AITS head airbag	
ITS head airbag	
Satellites	
Side airbag	
Safety mechanisms	
Seat belt tensioner	52
Mechanical seat belt tensioner	
Pyrotechnic inertia reel tensioners / anchor-fitting tensioners	
Pyrotechnic seat belt tensioners	
Seat-integrated seat belt system SGS	
Active head restraint	55
Function	
Rollover protection system	56
Function - 3 Series E36 and E46	
Function - 6 Series E64	
Safety battery terminal	58
Function	
Frequently asked questions	59
CleanEnergy	61

Introduction

Optimum safety under all conditions is one of the main objectives of BMW development and implementation.

Considering everything in its entirety, the active and passive safety systems which are attuned precisely to each other exceed the legal requirements and also consider the technical prerequisites for the rescue operation.

In effect, this also involves providing specific information on dealing with the BMW restraint and safety systems and tips on using rescue equipment.

Without submitting the casualties to any further danger, the highest priority of the Rescue Services is to save the life of the casualties by gaining access to the injured persons as quickly as possible. For this reason, it is essential to have a trained rescue team with knowledge about the function and operating principles of the safety systems and characteristics of the vehicle.

Due to the high-strength steels used in the continuous further development of the automotive industry, it is recommended to see to the appropriate, current rescue equipment.

In order to satisfy the needs and requirements that occur in practice, we have compiled this brochure in close cooperation with the Munich Fire Service.

BMW Service

MINI Service

Munich Fire Service



Basics

The rescue procedure must be coordinated medically and technically hand in hand.

Medical aspects

First of all, access must be established to the (trapped) persons. Non-jolting methods should be used here if at all possible.

The urgent life-saving measures and the initial examination (basic check) must be performed whilst the persons are still inside the accident vehicle.

Exceptions

- Immediate danger posed by fire or crash
- Crash rescue operation required for medical reasons

In all cases, it is absolutely essential to avoid (frantically) pulling the person out of the vehicle. The injured person should initially be left in the vehicle provided there is no immediate danger to the person or rescuer.

The medical measures that are carried out in the vehicle should be restricted to those that are the most essential. However, in the case of unconscious persons, this involves preserving the vital functions by means of infusion / intubation with artificial respiration.

In this case, the doctor / paramedic must be provided with access to the person so that he / she can carry out the urgent life-saving measures.

Before initiating any rescue measures, **always** immobilise the injured persons, i.e. provide suitable restraints.

During the rescue measures, the injured persons must be provided with **permanent** medical care.

It is absolutely essential to follow a caring procedure.

Technical aspects

- Identification of the vehicle model
- Visual inspection to ascertain fitted restraint and safety systems
- Body peculiarities with regard to the deployment of hydraulic rescue equipment

Automatic emergency call - "BMW ASSIST"

If a customer has a service contract for BMW ASSIST and one of the airbags or the crash sensor is triggered, an emergency call is automatically made to the service provider via the factory-installed, activated mobile phone in conjunction with the navigation system.

The current position of the vehicle is communicated via SMS to the service provider. The service provider tries to make a call back to the transmitted phone number. If this attempt fails, the nearest rescue centre is notified and a rescue operation is initiated.

If a connection cannot be made to a service provider, the general emergency call centre (112) is informed in order to initiate the rescue operation.

Response of restraint and safety systems after an accident

The restraint systems are not usually triggered when a vehicle is stationary.

Exceptions

- Heating solid fuel in the gas generator (airbag) to over 200 °C
- Massive mechanical strain on the airbag modules (sawing, drilling, grinding, welding)
- Short circuit in the electrical wires for activating the squibs
- The stationary vehicle is hit by another vehicle. (The restraint systems are triggered provided the triggering criteria are satisfied.)

Battery

The safety battery terminal only disconnects the positive battery lead between battery and starter / alternator.

In order to de-energise the protection systems, switch off the ignition and disconnect **both** battery leads (first negative and then positive) from the battery.

Important

If the vehicle **cannot be de-energised**:

- Move heads out of the deployment range of the airbags which have not been triggered if heavy life-saving equipment is used
- Tend to injured persons from the side

Child restraint systems

Passenger and side airbags can be deactivated when child restraint systems are being used. In this case, stickers are attached next to the relevant airbag.

Use of radio equipment

It is quite safe to use radio telephones / walkie-talkies in the immediate vicinity of untriggered restraint systems.

Special protective glass

The 5 Series (E39, E60, E61), 6 Series (E63), 7 Series (E38, E65, E66) and X5 (E53) models can be fitted with special protective glass. This can be recognised from the outside because the glass is thicker.

General overview of restraint and safety systems

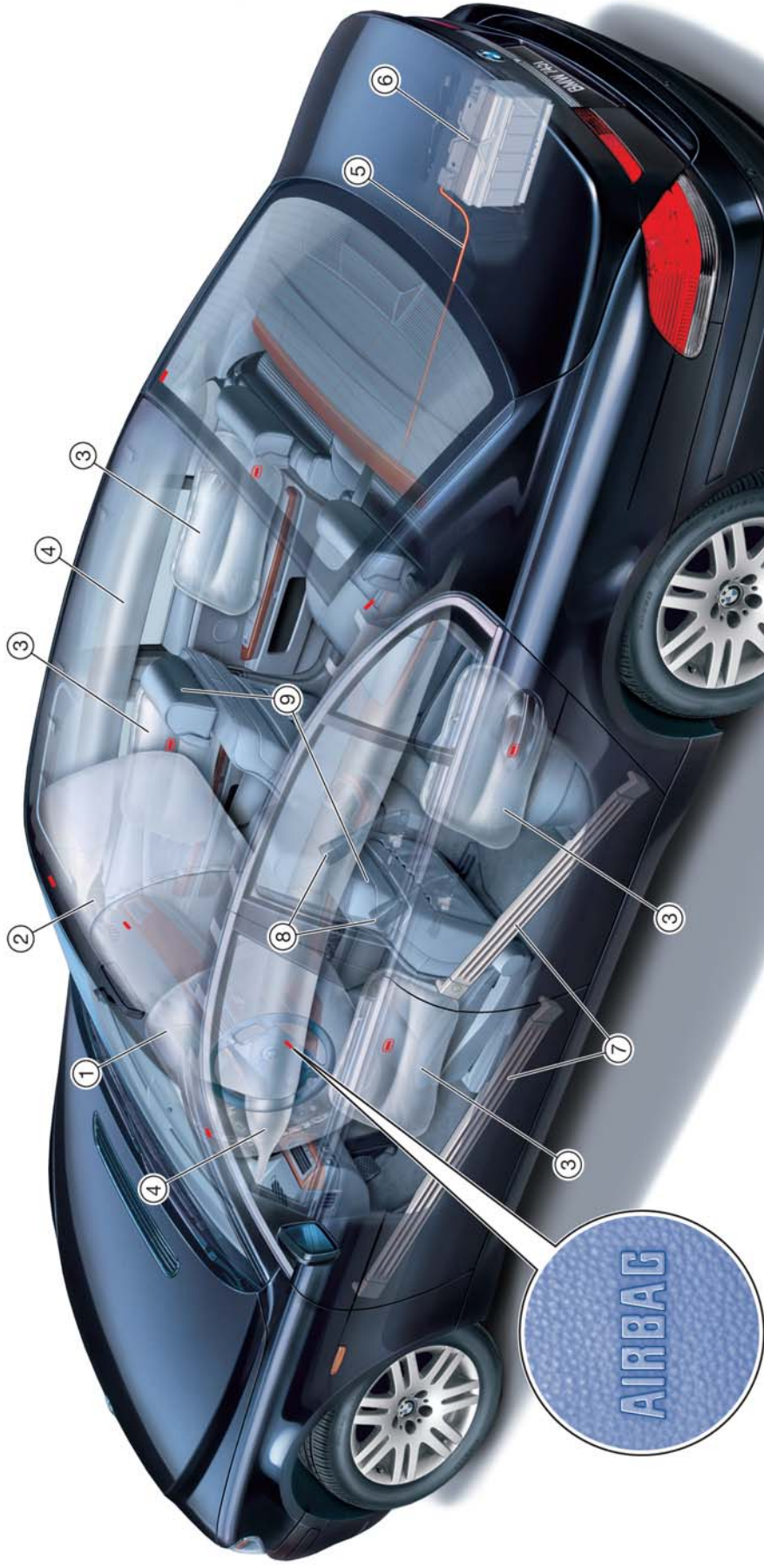

- 1 Driver's airbag
- 2 Passenger airbag
- 3 Side airbag
- 4 Head airbag
- 5 Battery positive cable
- 6 Battery
- 7 Side intrusion protection
- 8 Seat belt tensioner
- 9 Active head restraint

Identification of restraint and safety systems

Airbag systems

Driver's airbag

SRS, SRS Airbag or AIRBAG lettering on the steering wheel (steering wheel centre pad)

Passenger airbag

SRS, SRS Airbag or AIRBAG lettering on the instrument panel (front-passenger side)

Side airbag

BMW models (except the 1 Series):

SRS, SRS Airbag or AIRBAG lettering on the door trim panel (front and rear) in the door-lock area

BMW 1 Series and MINI models:

AIRBAG lettering on the outside of the backrest of the driver's and front passenger seats

Head airbag

SRS, SRS Airbag or AIRBAG lettering on the panel of the A and C-pillars

Knee airbag

AIRBAG lettering on the glove box flap (top right) or on the steering column casing (top left)

Safety battery terminal

No markings

The safety battery terminal is attached to the battery positive terminal.

The squib of the safety battery terminal must not be crushed, cut or heated.

Seat belt tensioner

No markings

Four types of system are used in the vehicles to reduce belt slack:

- Mechanical seat belt tensioners
- Pyrotechnic seat belt tensioners
- Pyrotechnic anchor-fitting tensioners
- Pyrotechnic inertia reel tensioners

Active head restraints

No markings

Active head restraints can currently only be installed in 7 Series (E65/66) models.

The active head restraints are integrated into the driver's and passenger seats.

There is no special procedure required for active head restraints that have not been triggered.

Rollover protection system

3 Series (E36) no markings

3 Series (E46) "Rollover protection system" marking on top side of head restraints of rear seats

6 Series (E64) "Rollover protection system" marking

The rollover protection system is only installed in 3 Series (E36, E46) convertible models and 6 Series (E64) models.

There is no special procedure required for rollover bars that have not been triggered.

Series / installation drawings

Saloon / Sedan

3 Series E90

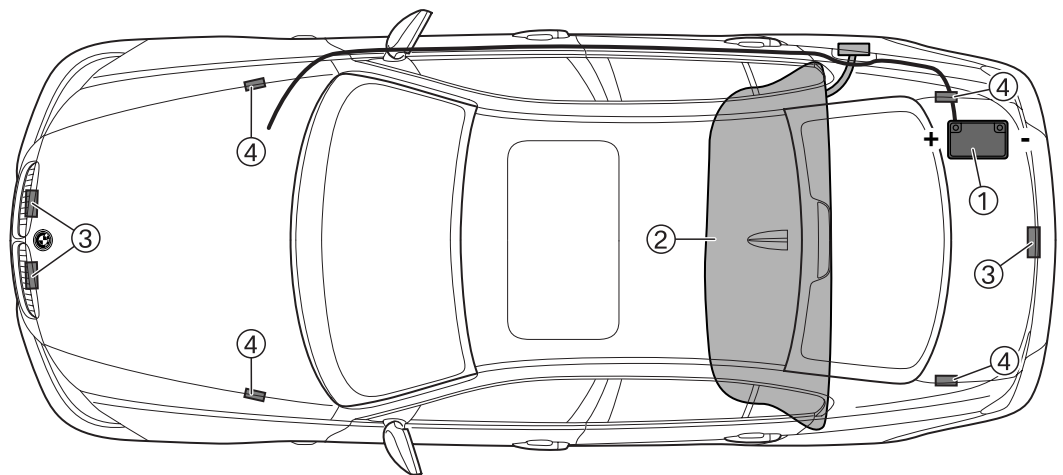

- 1 Battery
- 2 Fuel tank
- 3 Engine hood and luggage compartment locks
- 4 Engine hood and luggage compartment hinges

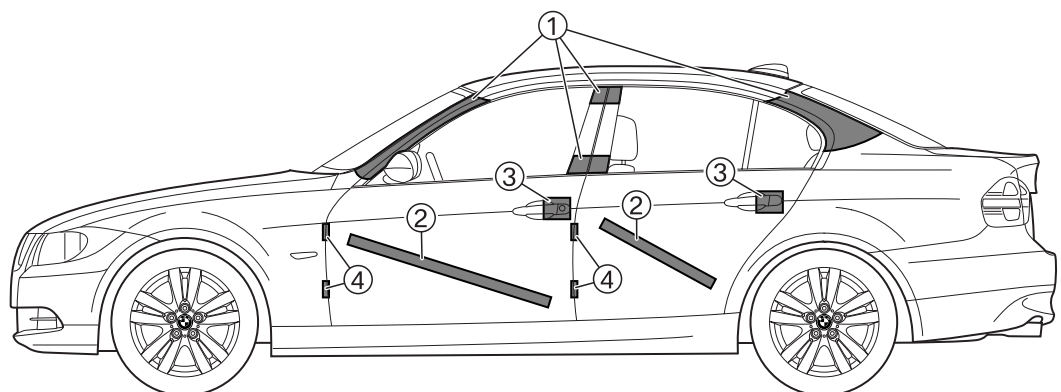

- 1 The surfaces indicate the areas from where the roof can be removed.
- 2 Side intrusion protection (diagonal)
- 3 Door locks
- 4 Door hinges

Series / installation drawings

Saloon / Sedan

3 Series E46

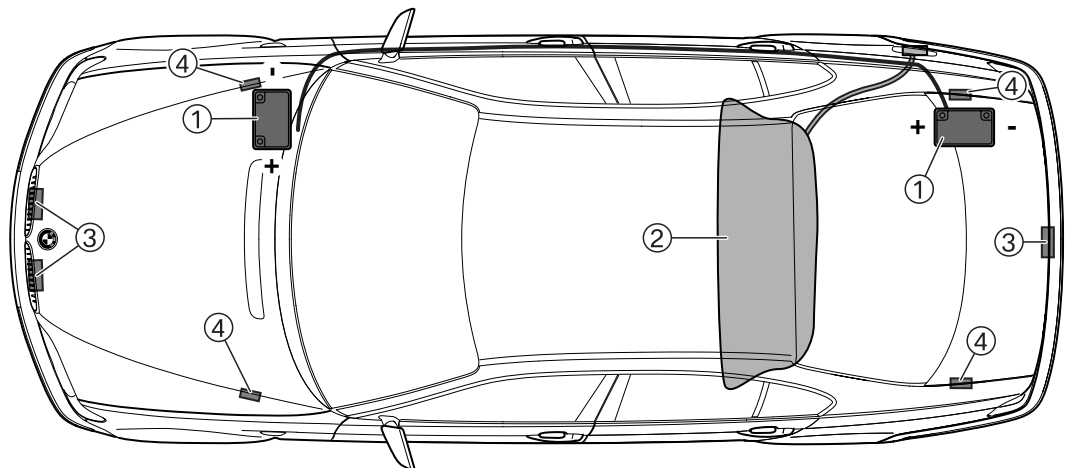

- 1 Battery (front **or** rear)
- 2 Fuel tank
- 3 Engine hood and luggage compartment locks
- 4 Engine hood and luggage compartment hinges

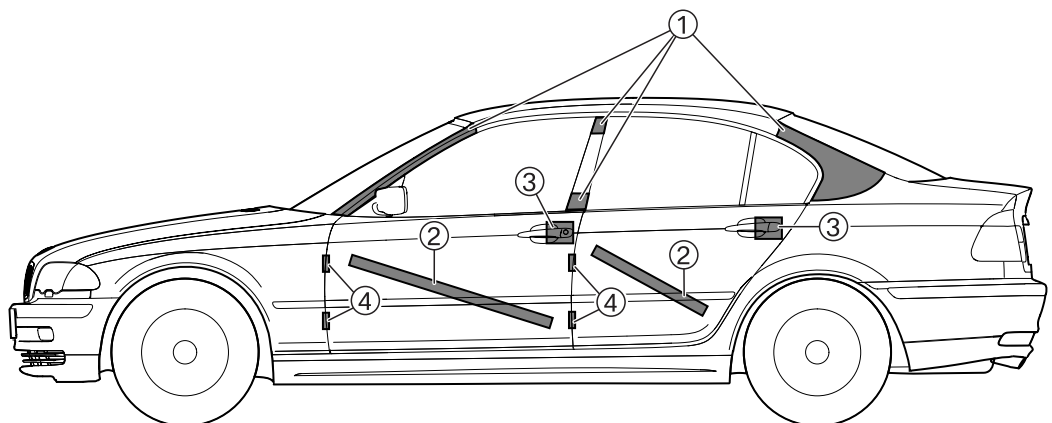

- 1 The surfaces indicate the areas from where the roof can be removed.
- 2 Side intrusion protection (diagonal)
- 3 Door locks
- 4 Door hinges

Series / installation drawings

Saloon / Sedan

3 Series E36

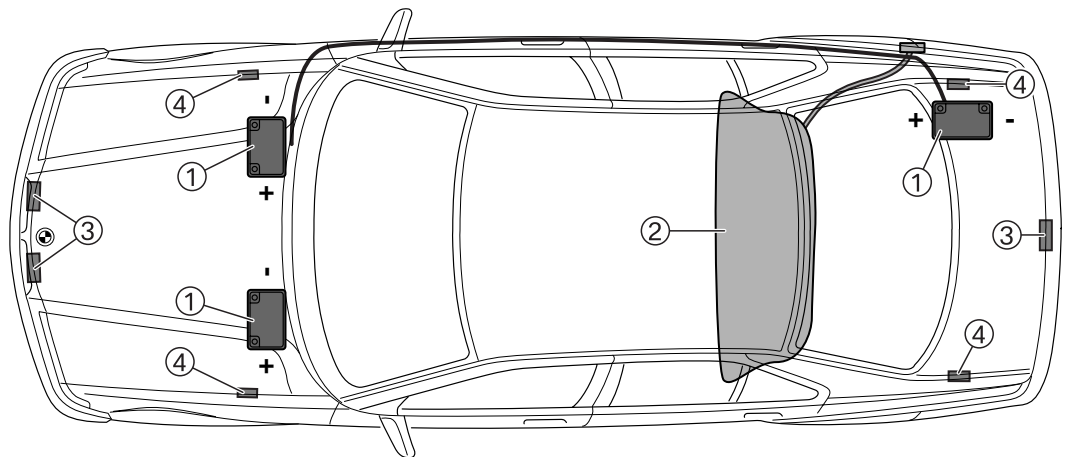

- 1 Battery (front left, front right **or** rear right)
- 2 Fuel tank
- 3 Engine hood and luggage compartment locks
- 4 Engine hood and luggage compartment hinges

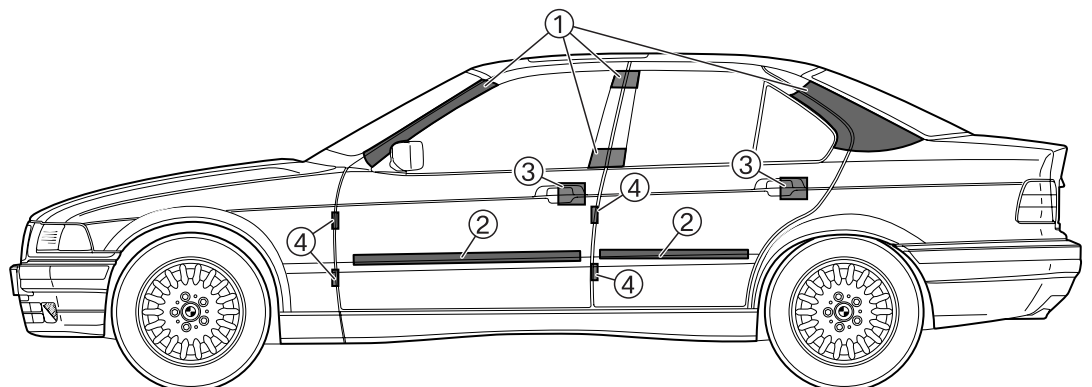

- 1 The surfaces indicate the areas from where the roof can be removed.
- 2 Side intrusion protection (horizontal)
- 3 Door locks
- 4 Door hinges

Series / installation drawings

Saloon / Sedan

5 Series E60

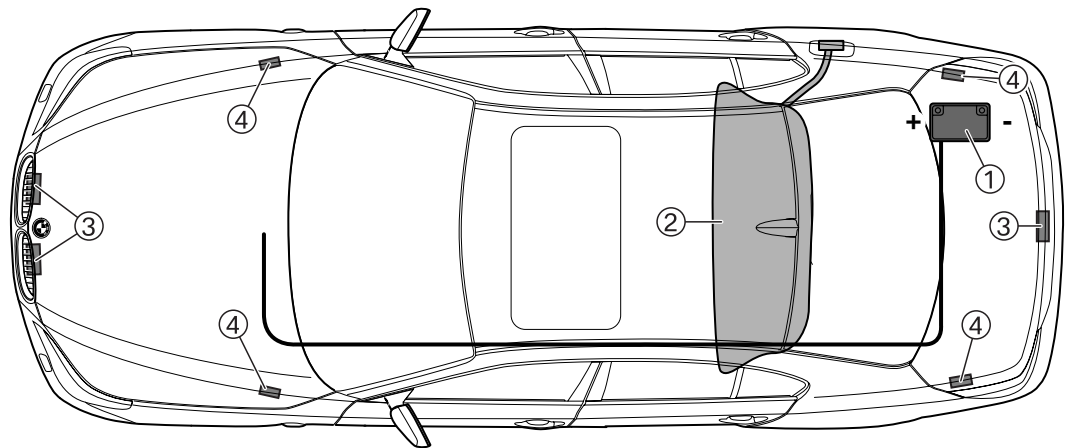

- 1 Battery
The positive battery lead is a ribbon cable and runs along the underbody on the **outside**.
- 3 Fuel tank
- 4 Engine hood and luggage compartment locks
- 5 Engine hood and luggage compartment hinges

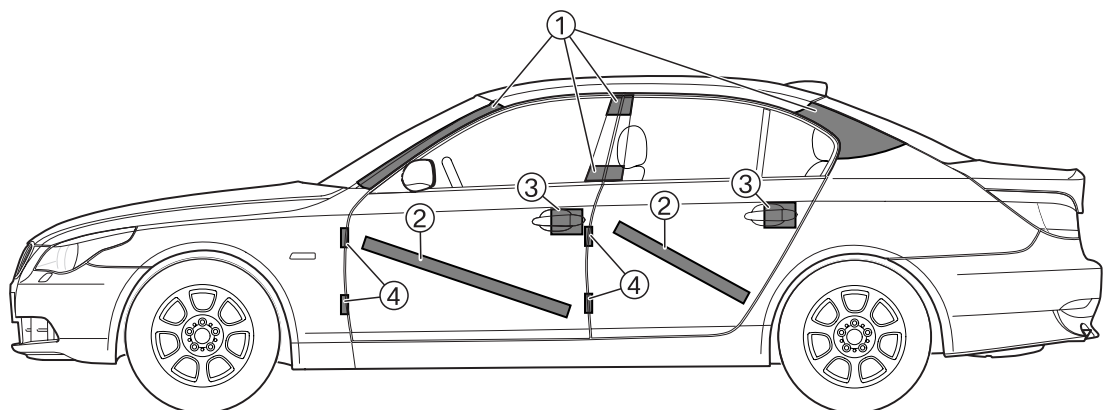

- 1 The surfaces indicate the areas from where the roof can be removed.
- 2 Side intrusion protection (diagonal)
- 3 Door locks
- 4 Door hinges

Series / installation drawings

Saloon / Sedan

5 Series E39

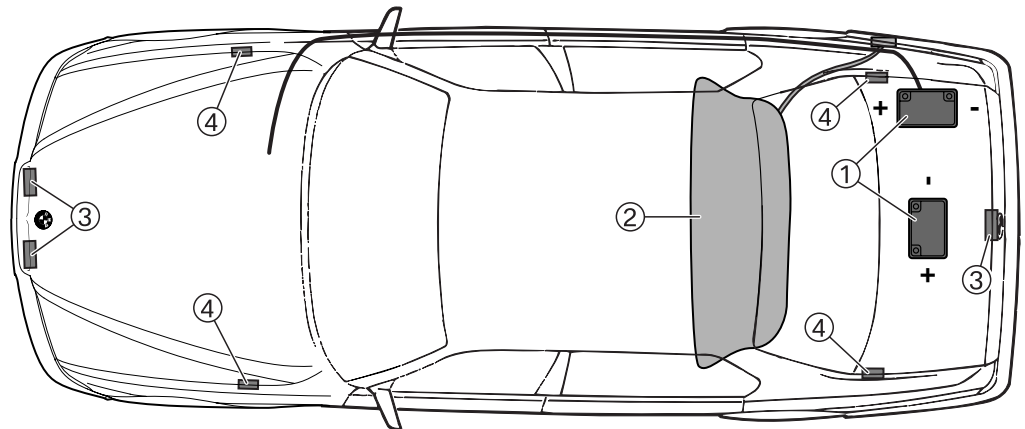

- 1 Battery (rear right **or** rear centre)
- 2 Fuel tank
- 3 Engine hood and luggage compartment locks
- 4 Engine hood and luggage compartment hinges

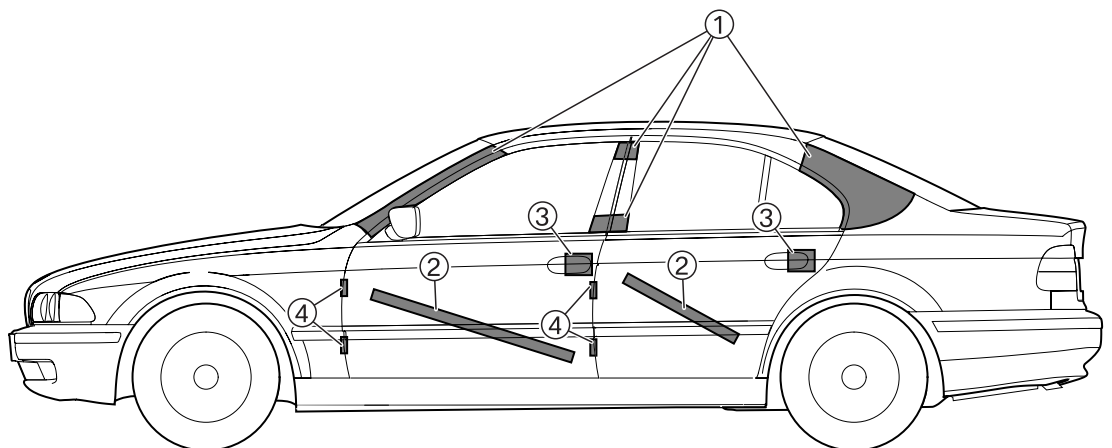

- 1 The surfaces indicate the areas from where the roof can be removed.
- 2 Side intrusion protection (diagonal)
- 3 Door locks
- 4 Door hinges

Series / installation drawings

Saloon / Sedan

5 Series E34

7 Series E32

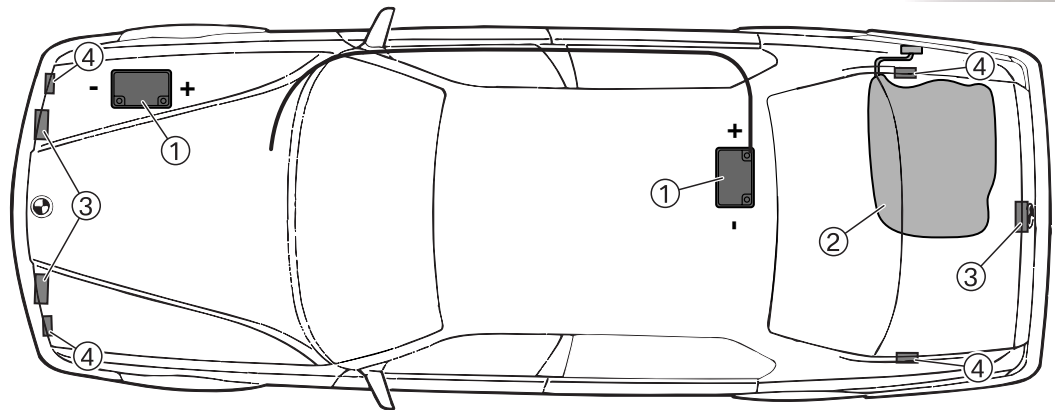

- 1 Battery (front right **or** beneath rear bench seat)
- 2 Fuel tank
- 3 Engine hood and luggage compartment locks
- 4 Engine hood and luggage compartment hinges

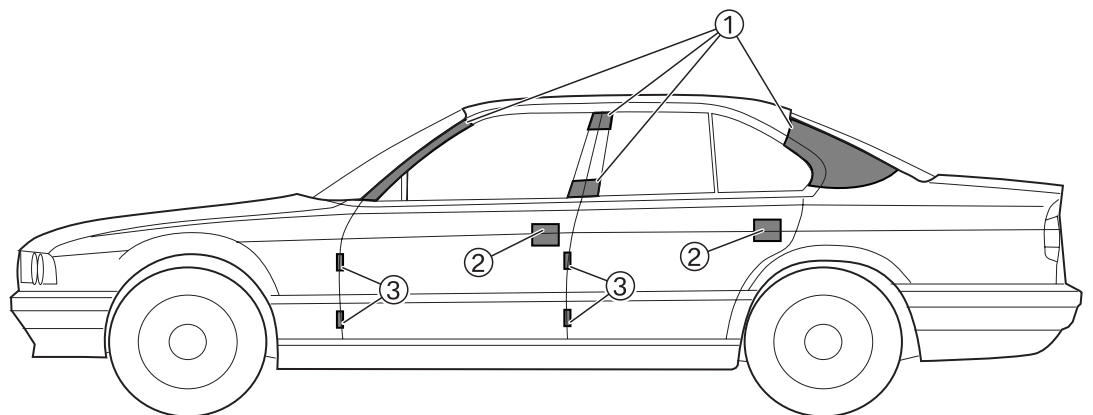

- 1 The surfaces indicate the areas from where the roof can be removed.
- 2 Door locks
- 3 Door hinges

Series / installation drawings

Saloon / Sedan

7 Series E65/66

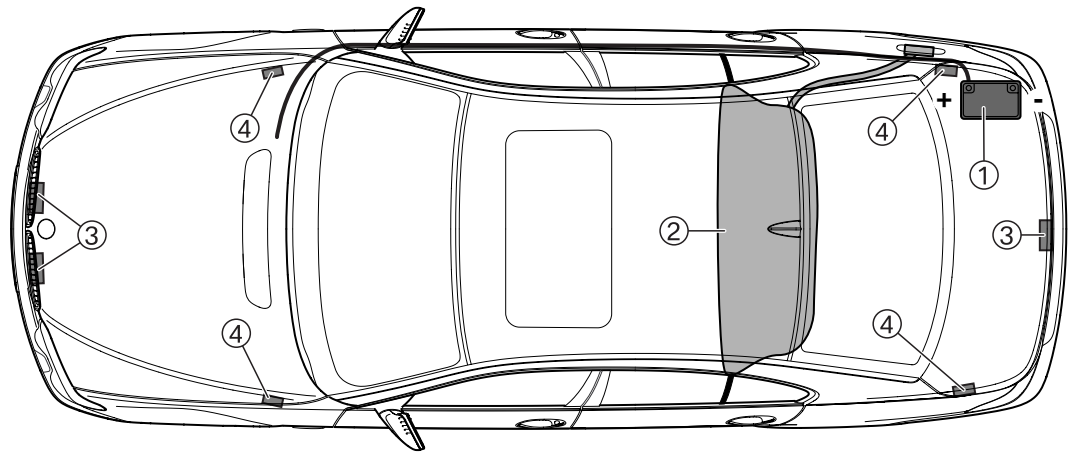

- 1 Battery
The positive battery lead is a ribbon cable.
- 2 Fuel tank
- 3 Engine hood and luggage compartment locks
- 4 Engine hood and luggage compartment hinges

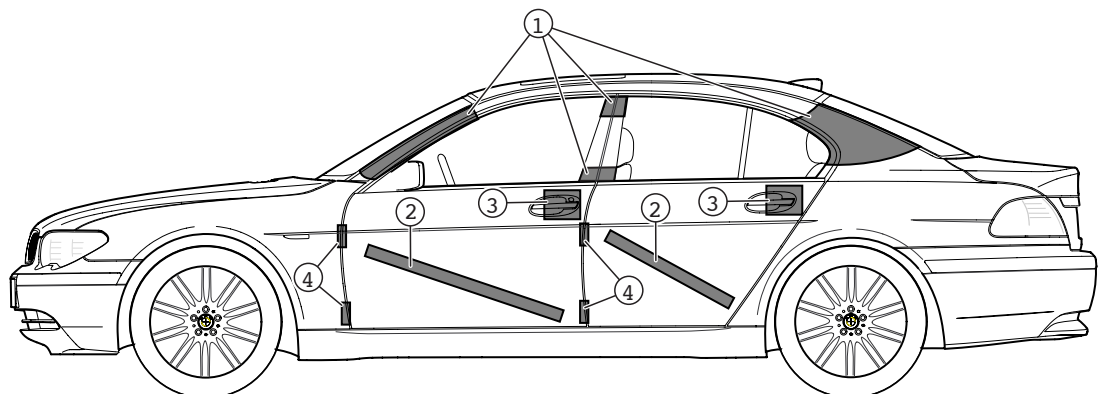

- 1 The surfaces indicate the areas from where the roof can be removed.
- 2 Side intrusion protection (diagonal)
- 3 Door locks
- 4 Door hinges

Series / installation drawings

Saloon / Sedan

7 Series E38

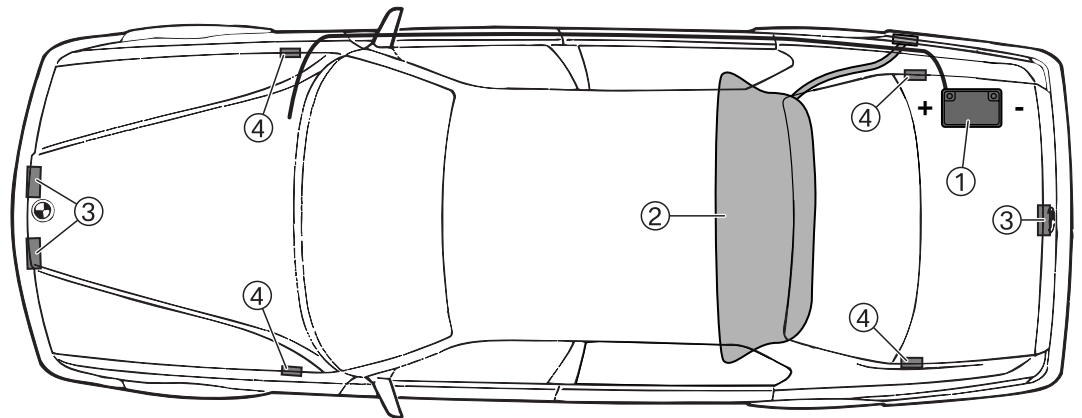

- 1 Battery
- 2 Fuel tank
- 3 Engine hood and luggage compartment locks
- 4 Engine hood and luggage compartment hinges

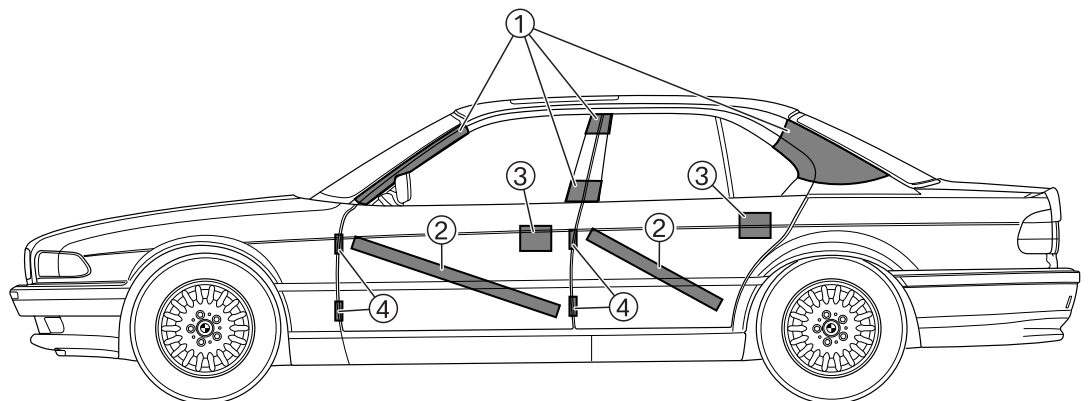

- 1 The surfaces indicate the areas from where the roof can be removed.
- 2 Side intrusion protection (diagonal)
- 3 Door locks
- 4 Door hinges

Series / installation drawings

Coupé

1 Series E87

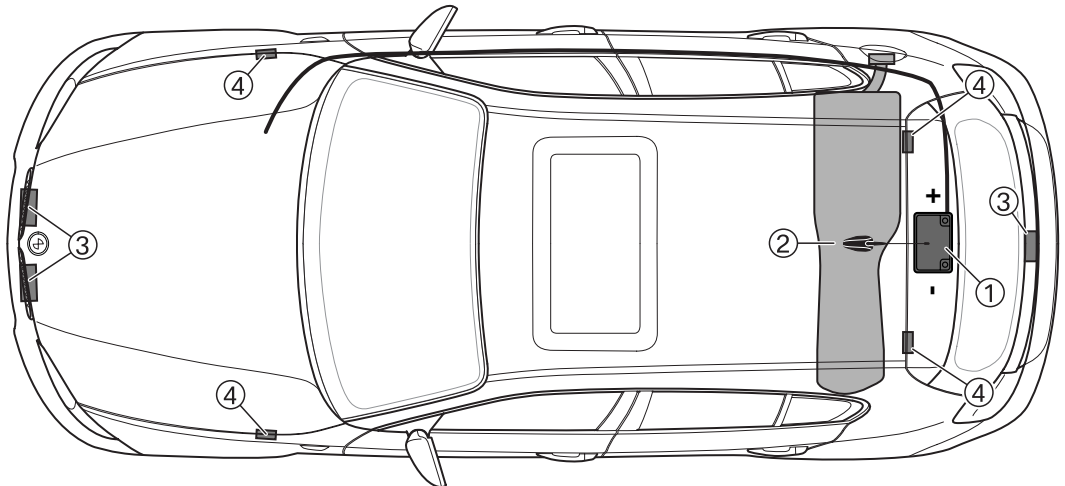

- 1 Battery
- 2 Fuel tank
- 3 Engine hood and luggage compartment locks
- 4 Engine hood and luggage compartment hinges

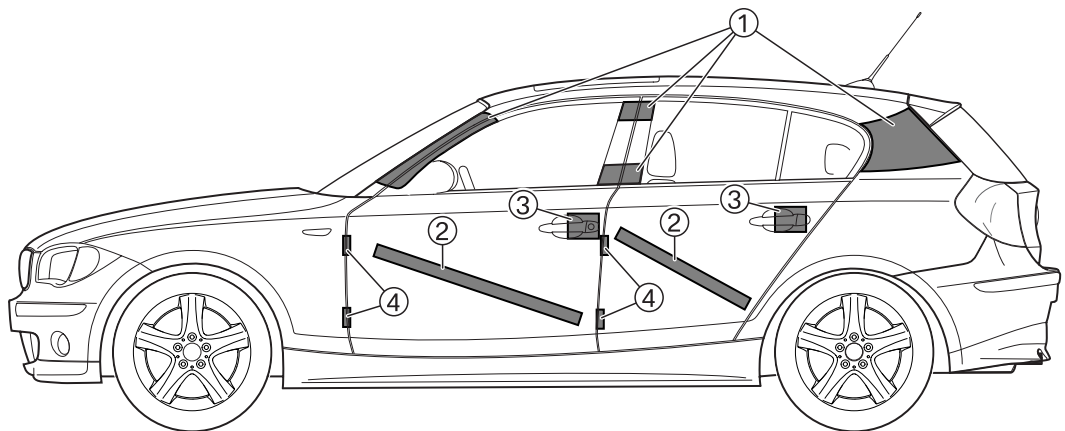

- 1 The surfaces indicate the areas from where the roof can be removed.
- 2 Side intrusion protection (diagonal)
- 3 Door locks
- 4 Door hinges

Series / installation drawings

Coupé

3 Series E46

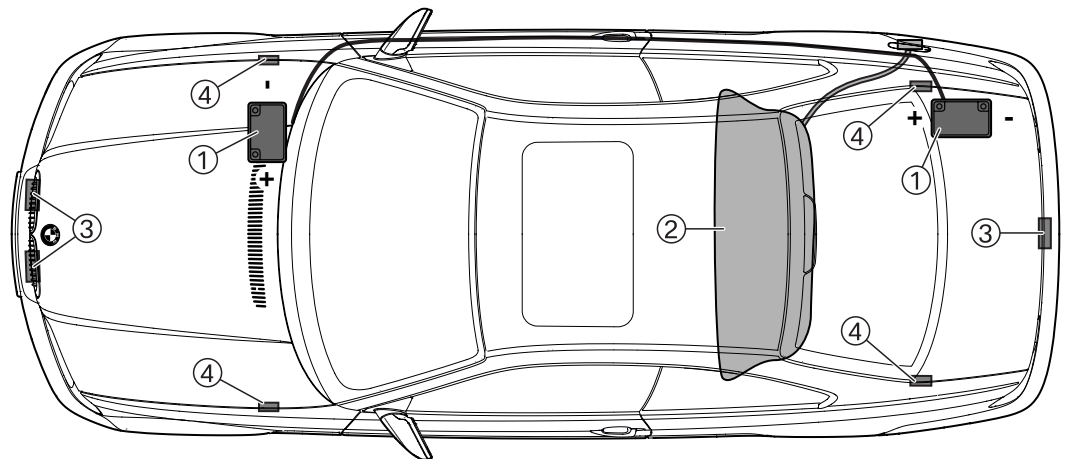

- 1 Battery (front **or** rear)
- 2 Fuel tank
- 3 Engine hood and luggage compartment locks
- 4 Engine hood and luggage compartment hinges

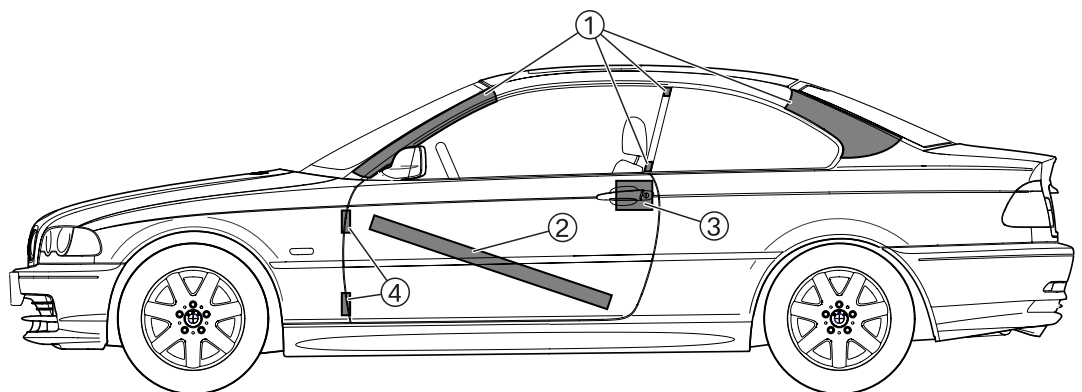

- 1 The surfaces indicate the areas from where the roof can be removed.
- 2 Side intrusion protection (diagonal)
- 3 Door locks
- 4 Door hinges

Series / installation drawings

Compact

3 Series E46 Compact

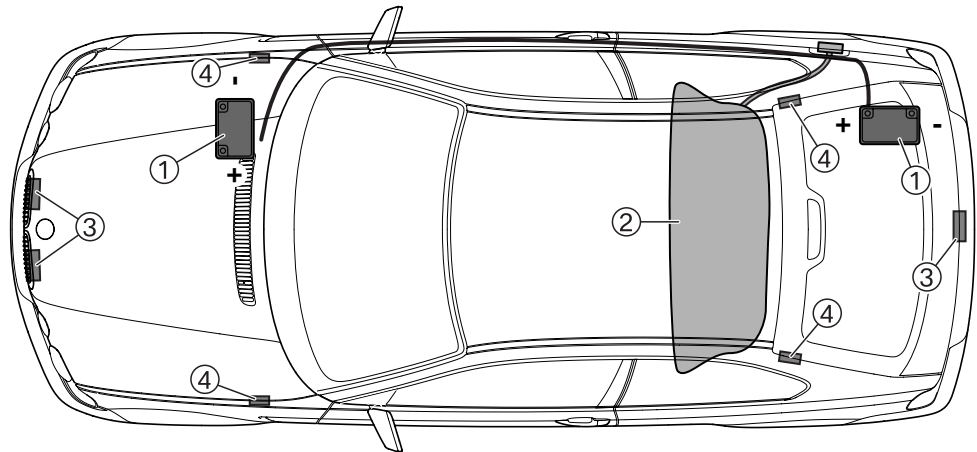

- 1 Battery (front **or** rear)
- 2 Fuel tank
- 3 Engine hood and luggage compartment locks
- 4 Engine hood and luggage compartment hinges

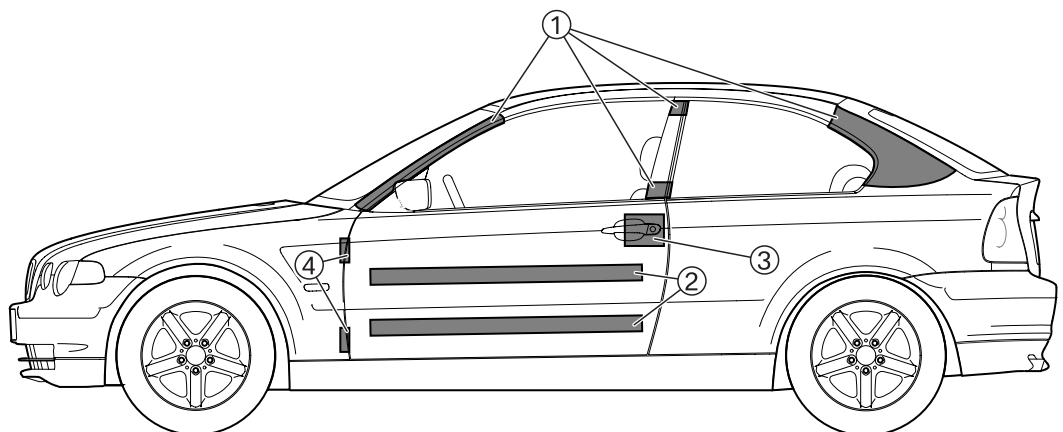

- 1 The surfaces indicate the areas from where the roof can be removed.
- 2 Side intrusion protection (horizontal)
- 3 Door locks
- 4 Door hinges

Series / installation drawings

Coupé

3 Series E36

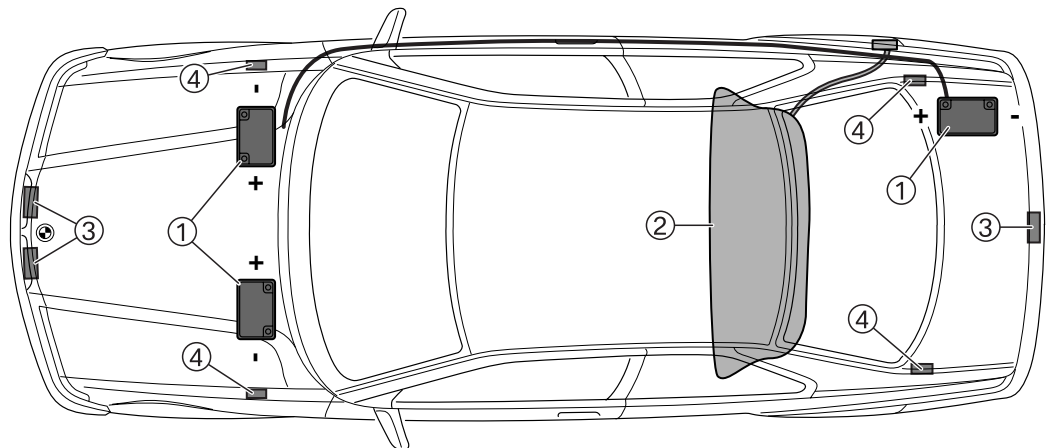

- 1 Battery (front left, front right **or** rear right)
- 2 Fuel tank
- 3 Engine hood and luggage compartment locks
- 4 Engine hood and luggage compartment hinges

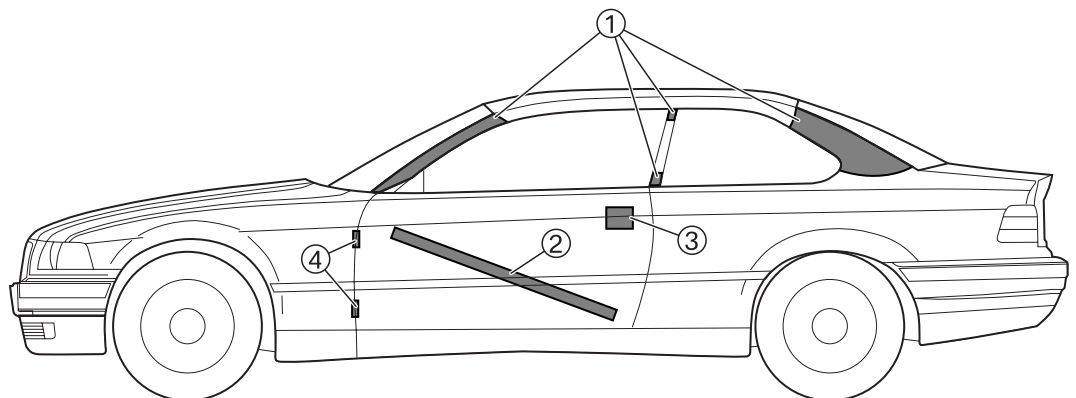

- 1 The surfaces indicate the areas from where the roof can be removed.
- 2 Side intrusion protection (diagonal)
- 3 Door locks
- 4 Door hinges

Series / installation drawings

Compact

3 Series E36 Compact

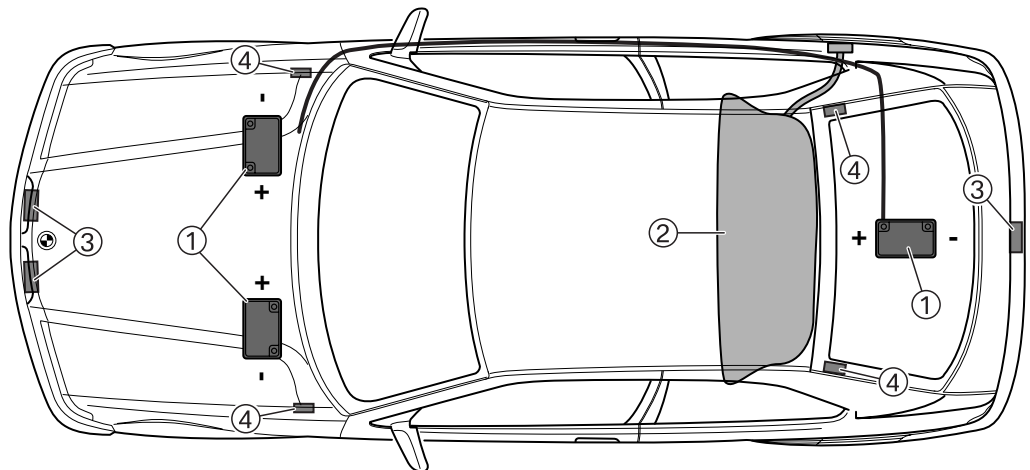

- 1 Battery (front left, front right **or** rear right)
- 2 Fuel tank
- 3 Engine hood and luggage compartment locks
- 4 Engine hood and luggage compartment hinges

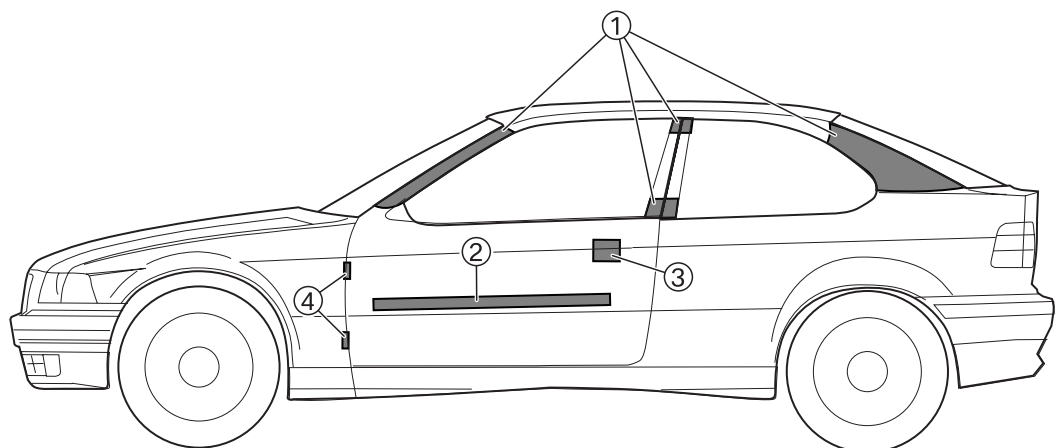

- 1 The surfaces indicate the areas from where the roof can be removed.
- 2 Side intrusion protection (horizontal)
- 3 Door locks
- 4 Door hinges

Series / installation drawings

Coupé

6 Series E63

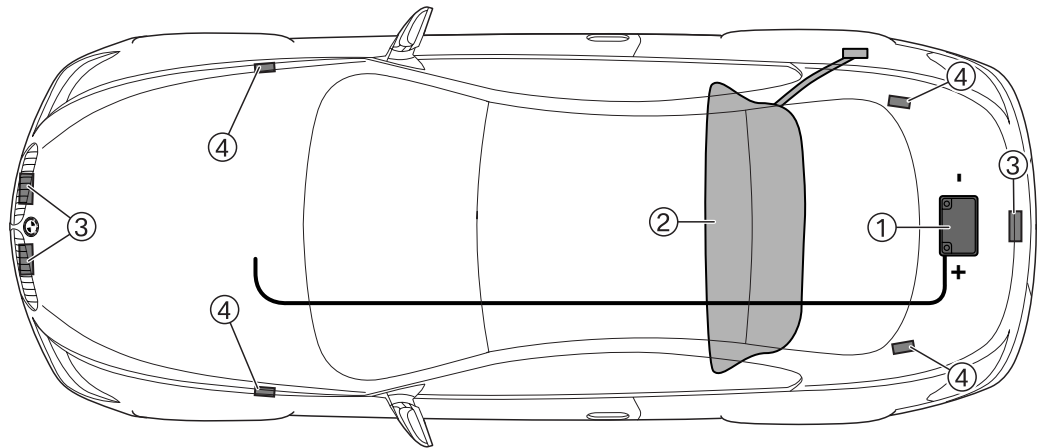

- 1 Battery
The positive battery lead is a ribbon cable and runs along the underbody on the **outside**.
- 2 Fuel tank
- 3 Engine hood and luggage compartment locks
- 4 Engine hood and luggage compartment hinges

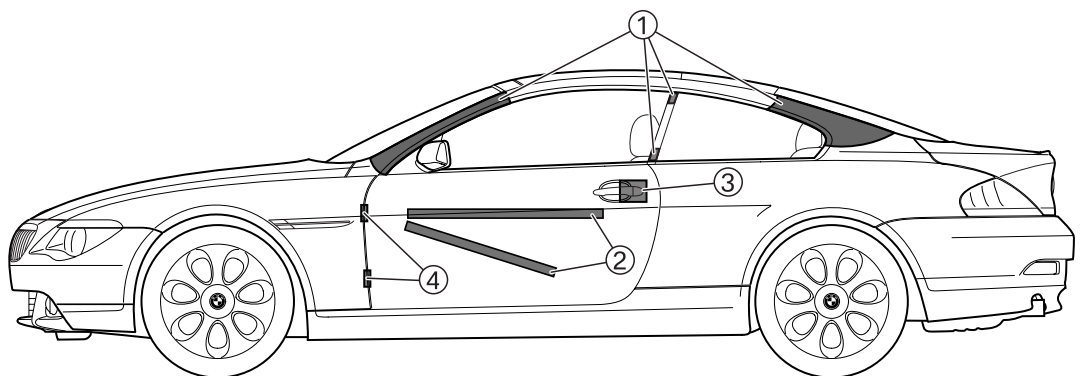

- 1 The surfaces indicate the areas from where the roof can be removed.
- 2 Side intrusion protection (diagonal and horizontal)
- 3 Door locks
- 4 Door hinges

Series / installation drawings

Coupé

Z3 Coupé - E36/7

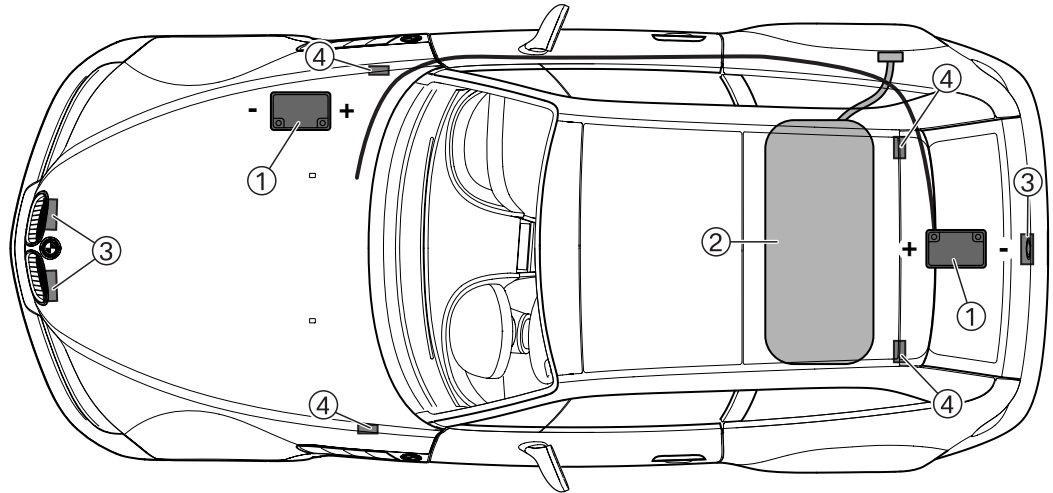

- 1 Battery (front right **or** rear centre)
- 2 Fuel tank
- 3 Engine hood and luggage compartment locks
- 4 Engine hood and luggage compartment hinges

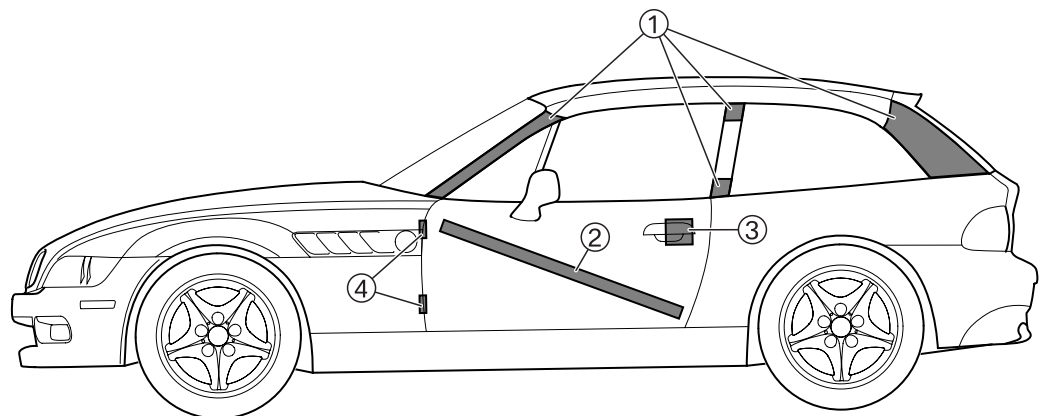

- 1 The surfaces indicate the areas from where the roof can be removed.
- 2 Side intrusion protection (diagonal)
- 3 Door locks
- 4 Door hinges

Series / installation drawings

Touring

3 Series E91

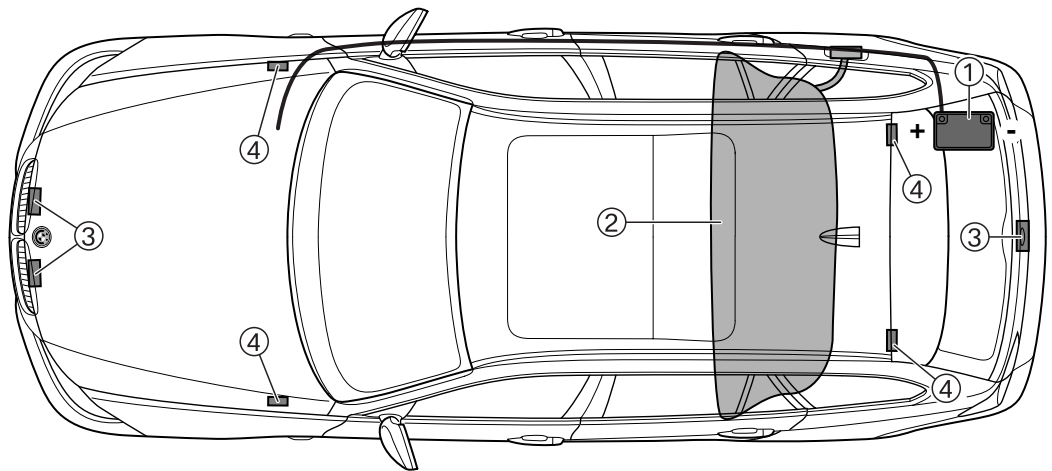

- 1 Battery
- 2 Fuel tank
- 3 Engine hood and luggage compartment locks
- 4 Engine hood and luggage compartment hinges

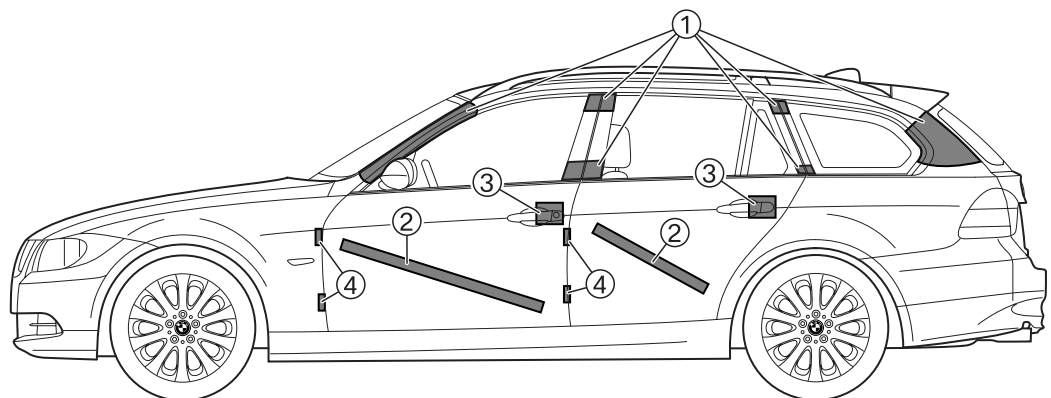

- 1 The surfaces indicate the areas from where the roof can be removed.
- 2 Side intrusion protection (diagonal)
- 3 Door locks
- 4 Door hinges

Series / installation drawings

Touring

3 Series E46

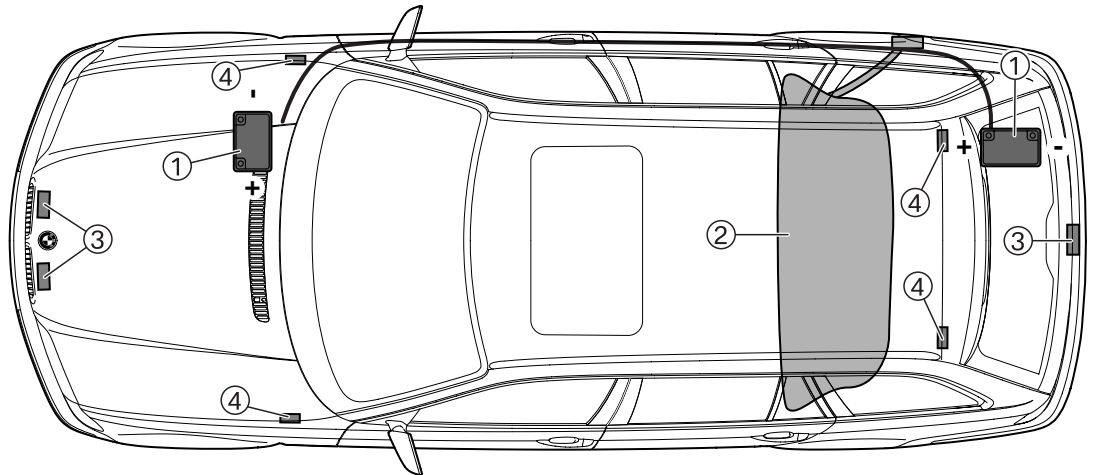

- 1 Battery (front **or** rear)
- 2 Fuel tank
- 3 Engine hood and luggage compartment locks
- 4 Engine hood and luggage compartment hinges

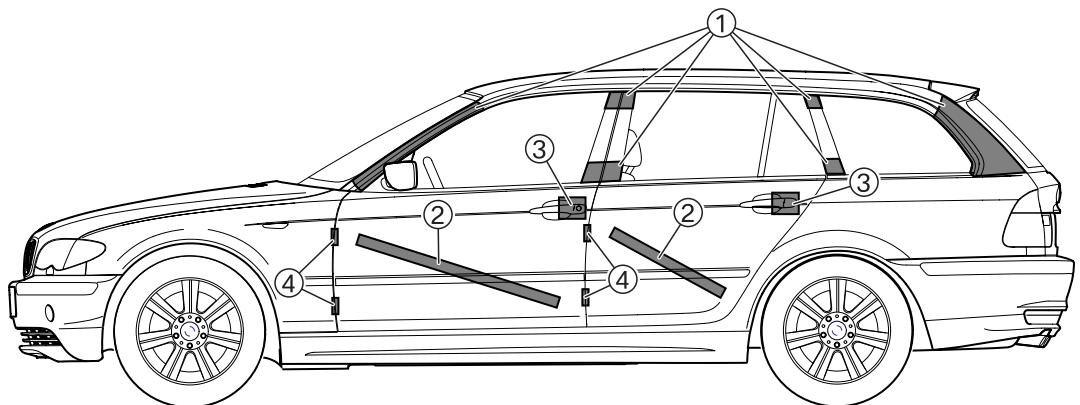

- 1 The surfaces indicate the areas from where the roof can be removed.
- 2 Side intrusion protection (diagonal)
- 3 Door locks
- 4 Door hinges

Series / installation drawings

Touring

3 Series E36

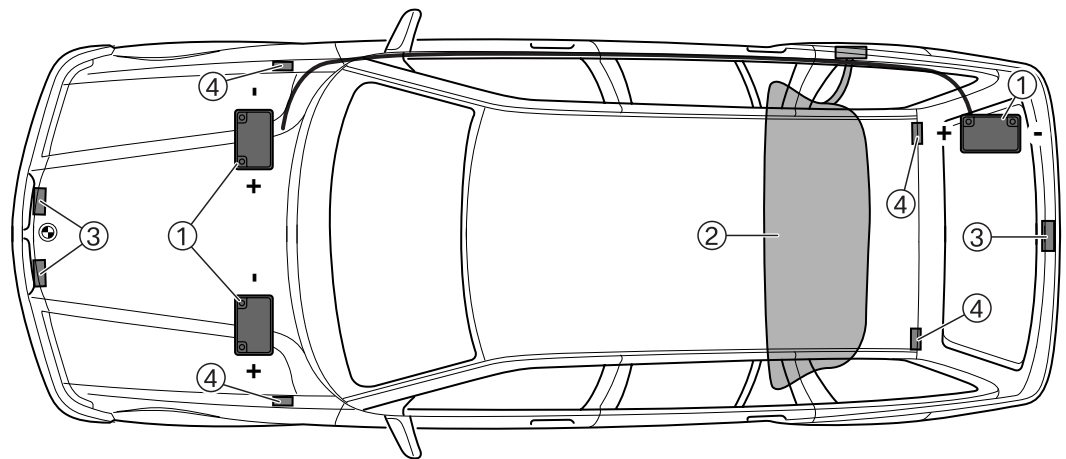

- 1 Battery (front left, front right **or** rear right)
- 2 Fuel tank
- 3 Engine hood and luggage compartment locks
- 4 Engine hood and luggage compartment hinges

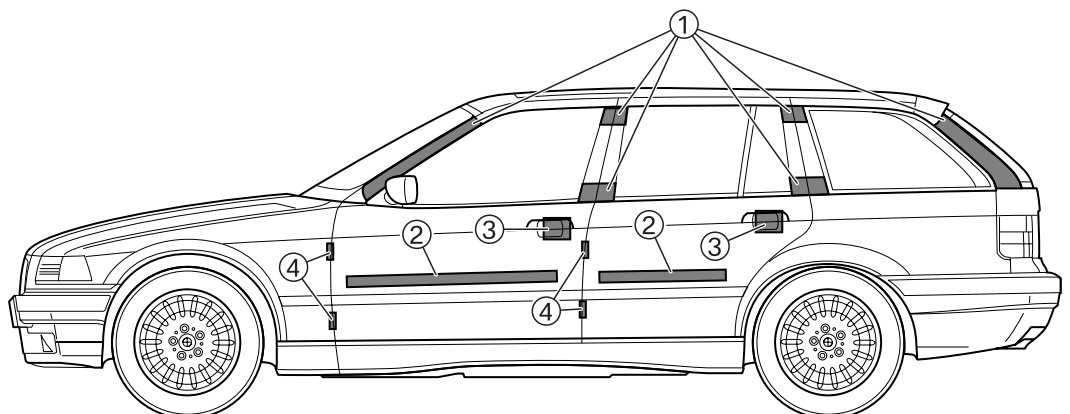

- 1 The surfaces indicate the areas from where the roof can be removed.
- 2 Side intrusion protection (horizontal)
- 3 Door locks
- 4 Door hinges

Series / installation drawings

Touring

5 Series E61

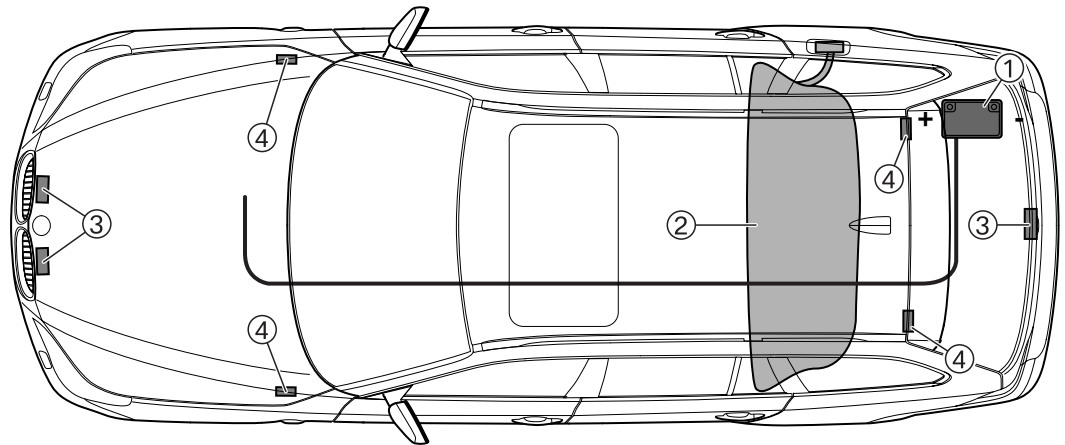

- 1 Battery
The positive battery lead is a ribbon cable and runs along the underbody on the **outside**.
- 2 Fuel tank
- 3 Engine hood and luggage compartment locks
- 4 Engine hood and luggage compartment hinges

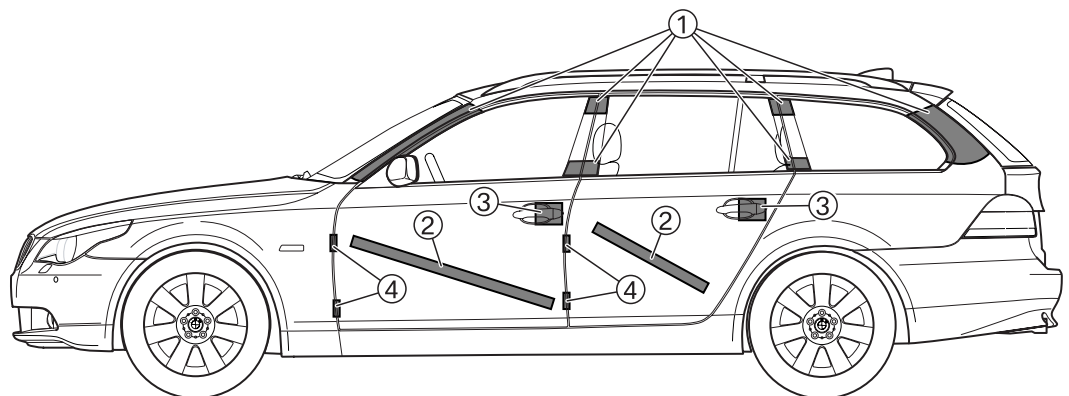

- 1 The surfaces indicate the areas from where the roof can be removed.
- 2 Side intrusion protection (diagonal)
- 3 Door locks
- 4 Door hinges

Series / installation drawings

Touring

5 Series E39

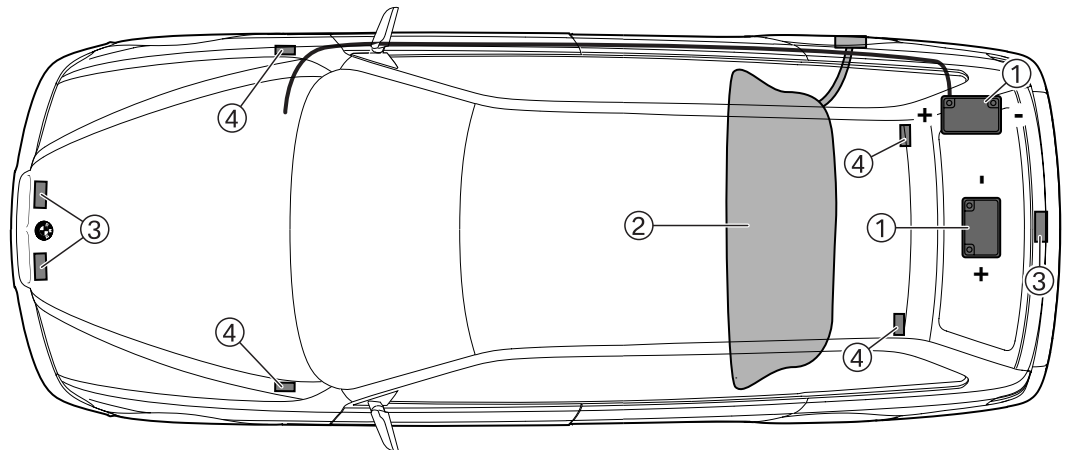

- 1 Battery (rear right **or** rear centre)
- 2 Fuel tank
- 3 Engine hood and luggage compartment locks
- 4 Engine hood and luggage compartment hinges

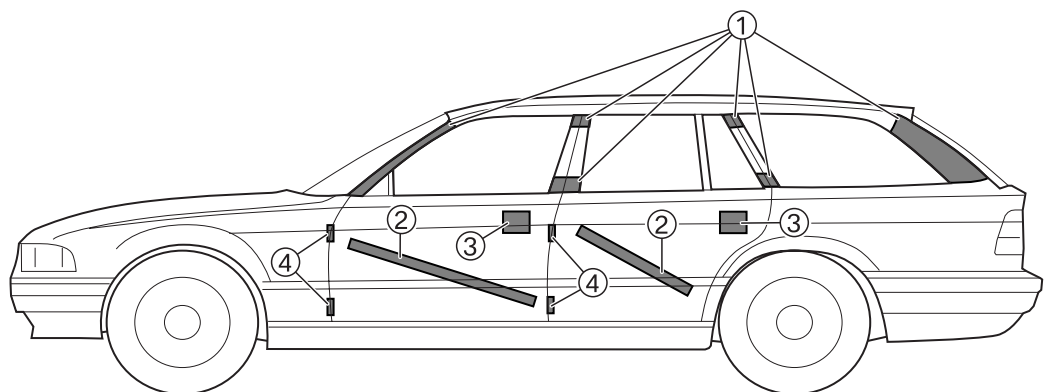

- 1 The surfaces indicate the areas from where the roof can be removed.
- 2 Side intrusion protection (diagonal)
- 3 Door locks
- 4 Door hinges

Series / installation drawings

Touring

5 Series E34

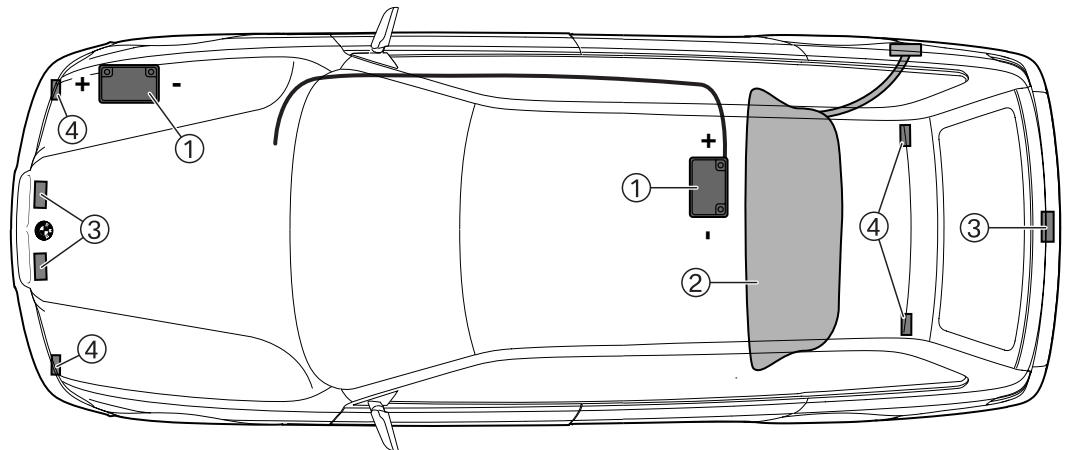

- 1 Battery (front right **or** beneath the rear bench seat)
- 2 Fuel tank
- 3 Engine hood and luggage compartment locks
- 4 Engine hood and luggage compartment hinges

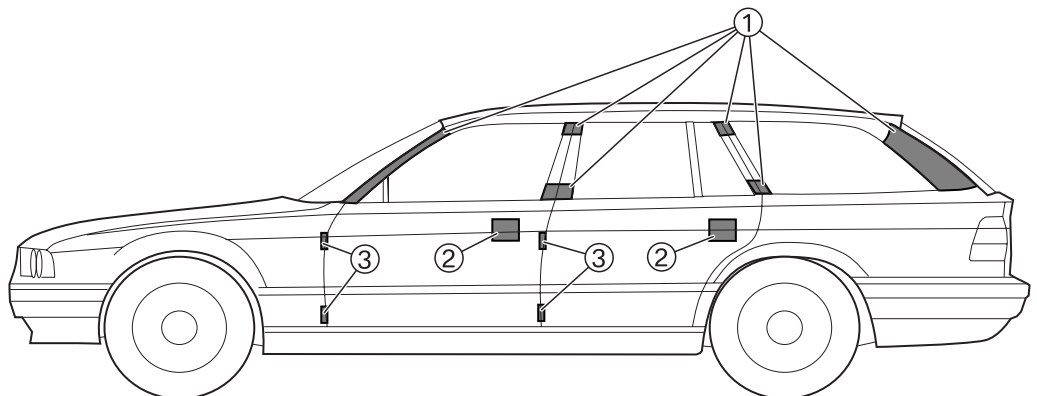

- 1 The surfaces indicate the areas from where the roof can be removed.
- 2 Door locks
- 3 Door hinge

Convertible

3 Series E46

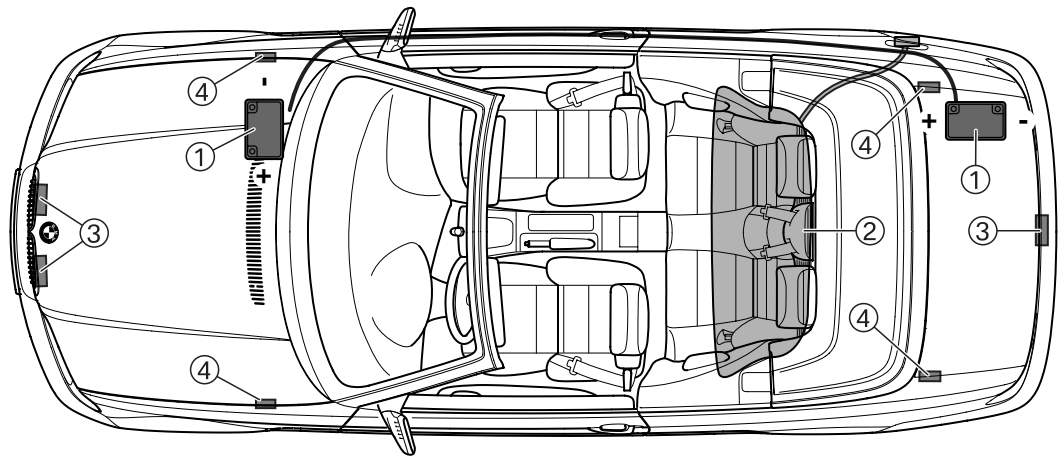

- 1 Battery (front **or** rear)
- 2 Fuel tank
- 3 Engine hood and luggage compartment locks
- 4 Engine hood and luggage compartment hinges

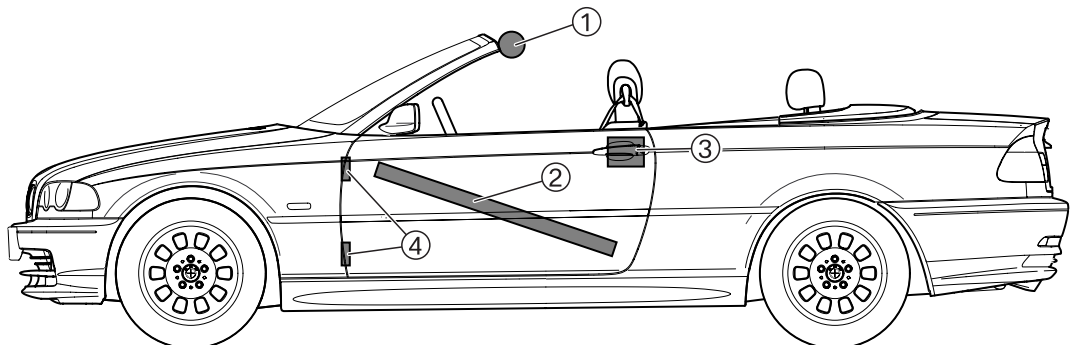

- 1 The windscreen frame is strengthened so the roof can be separated from the convertible top frame.
- 2 Side intrusion protection (diagonal)
- 3 Door locks
- 4 Door hinge

Series / installation drawings

Convertible

3 Series E36

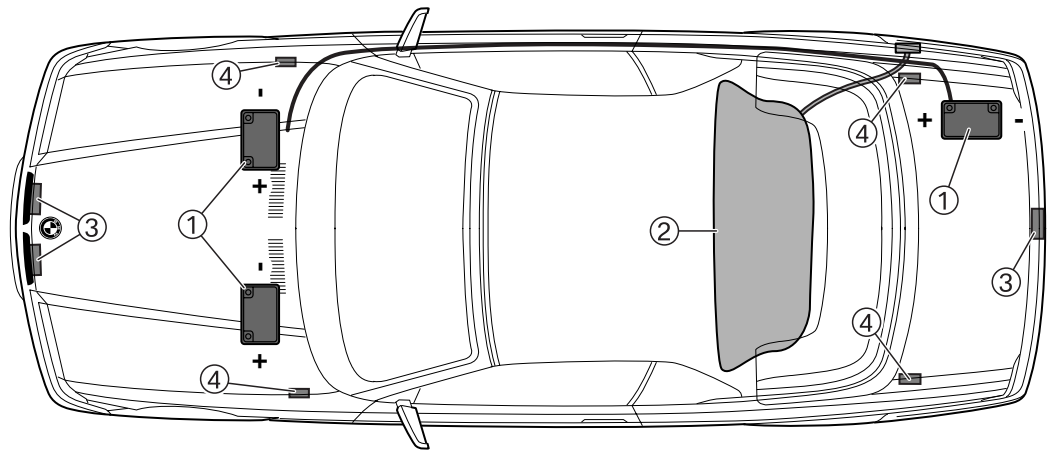

- 1 Battery (front left, front right **or** rear right)
- 2 Fuel tank
- 3 Engine hood and luggage compartment locks
- 4 Engine hood and luggage compartment hinges

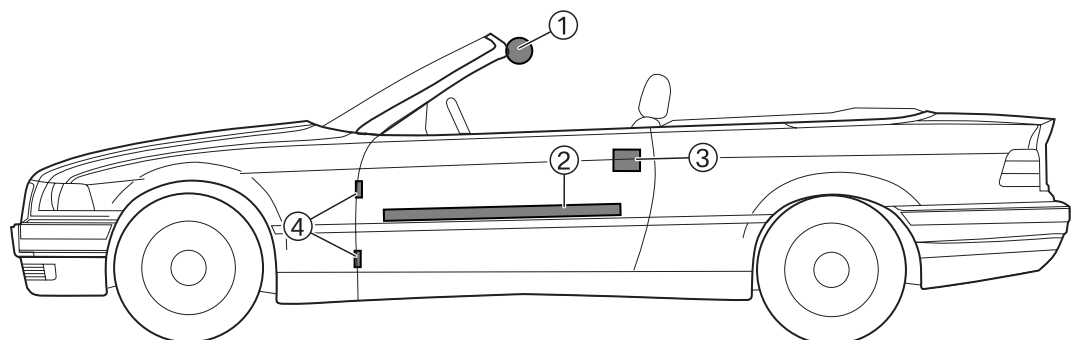

- 1 The windscreen frame is strengthened so the roof can be separated from the convertible top frame.
- 2 Side intrusion protection (horizontal)
- 3 Door locks
- 4 Door hinge

Series / installation drawings

Convertible

6 Series E64

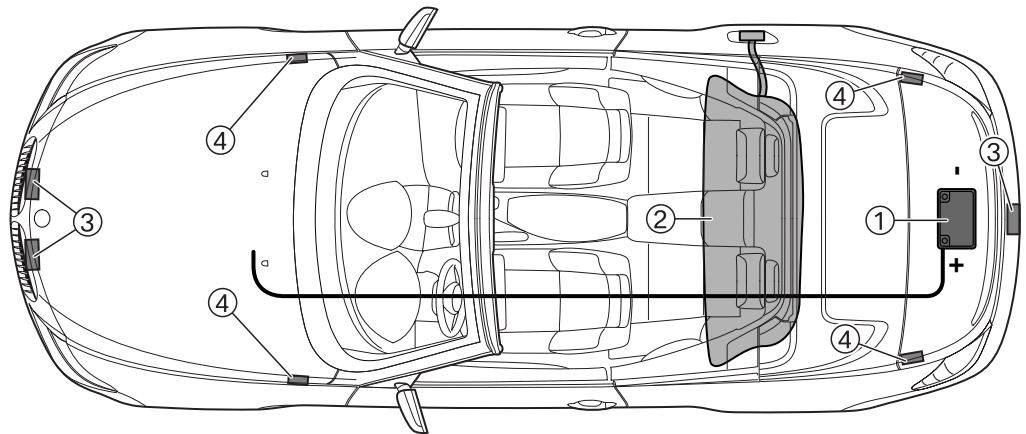

- 1 Battery
The positive battery lead is a ribbon cable and runs along the underbody on the **outside**.
- 2 Fuel tank
- 3 Engine hood and luggage compartment locks
- 4 Engine hood and luggage compartment hinges

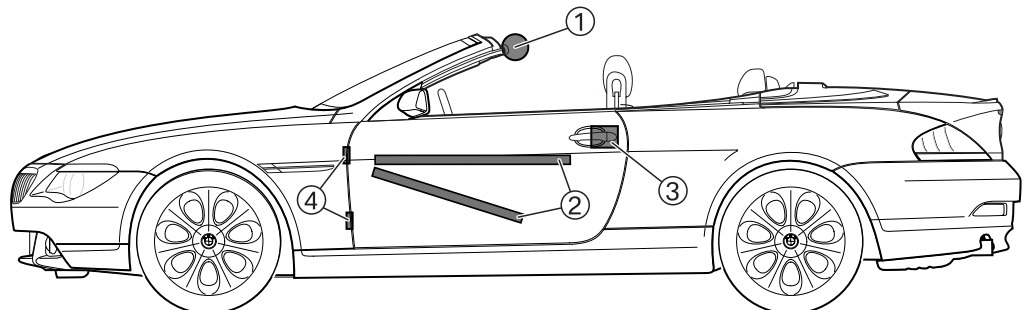

- 1 The windscreen frame is strengthened so the roof can be separated from the convertible top frame.
- 2 Side intrusion protection (diagonal and horizontal)
- 3 Door locks
- 4 Door hinge

Series / installation drawings

Convertible

Z3 Roadster - E36/7

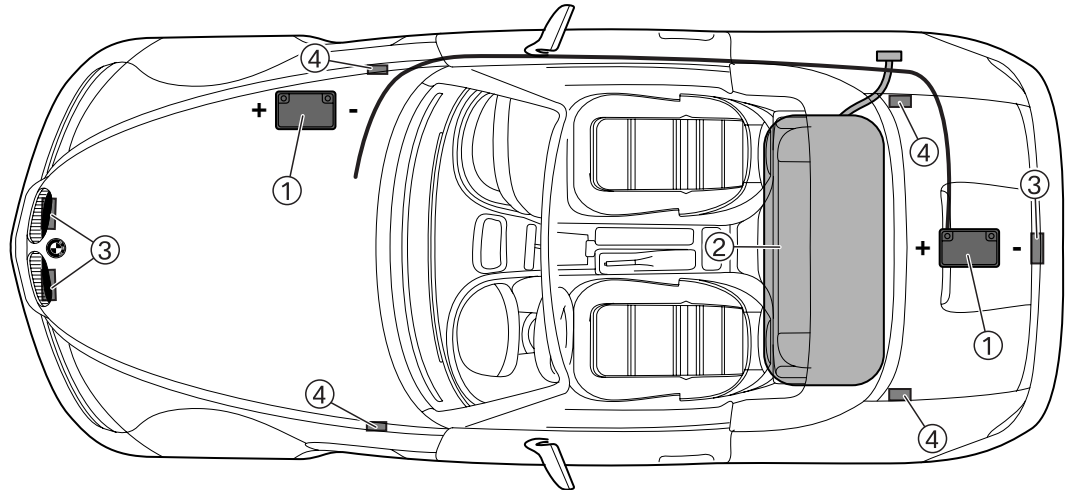

- 1 Battery (front right **or** rear centre)
- 2 Fuel tank
- 3 Engine hood and luggage compartment locks
- 4 Engine hood and luggage compartment hinges

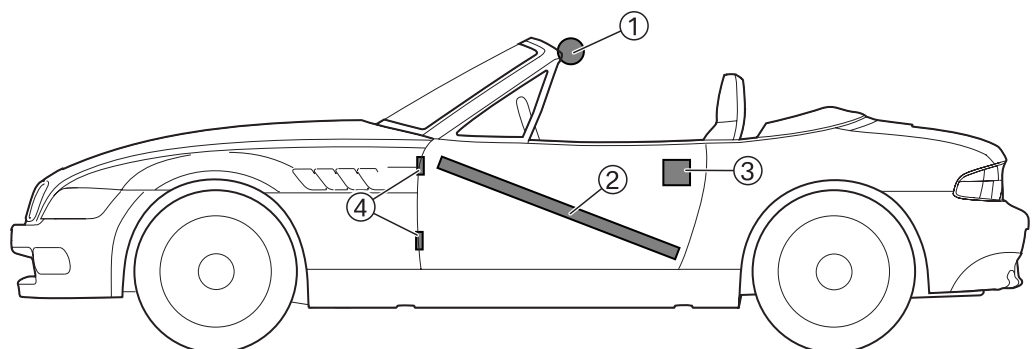

- 1 The windscreen frame is strengthened so the roof can be separated from the convertible top frame.
- 2 Side intrusion protection (diagonal)
- 3 Door locks
- 4 Door hinge

Series / installation drawings

Convertible

Z4 Roadster - E85

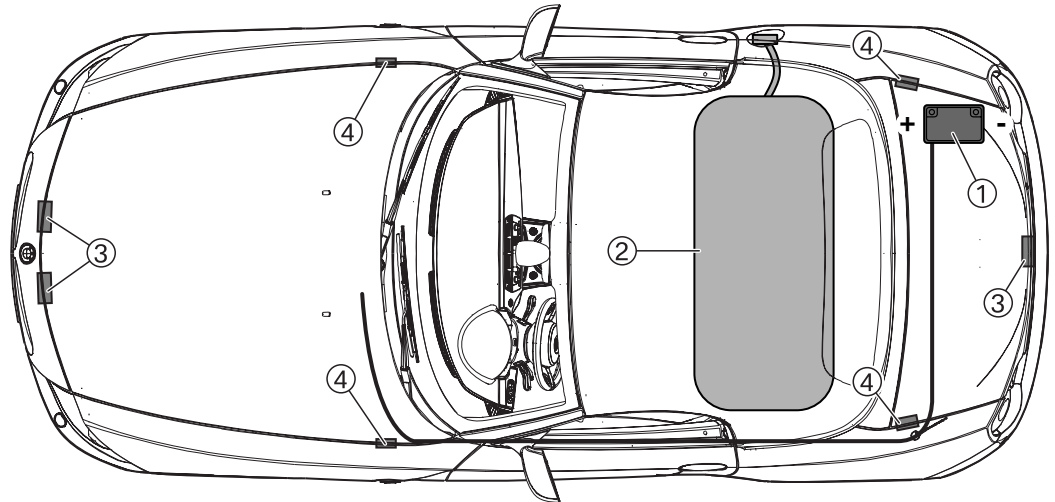

- 1 Battery
The positive battery lead is a ribbon cable and runs along the underbody on the **outside**.
- 2 Fuel tank
- 3 Engine hood and luggage compartment locks
- 4 Engine hood and luggage compartment hinges

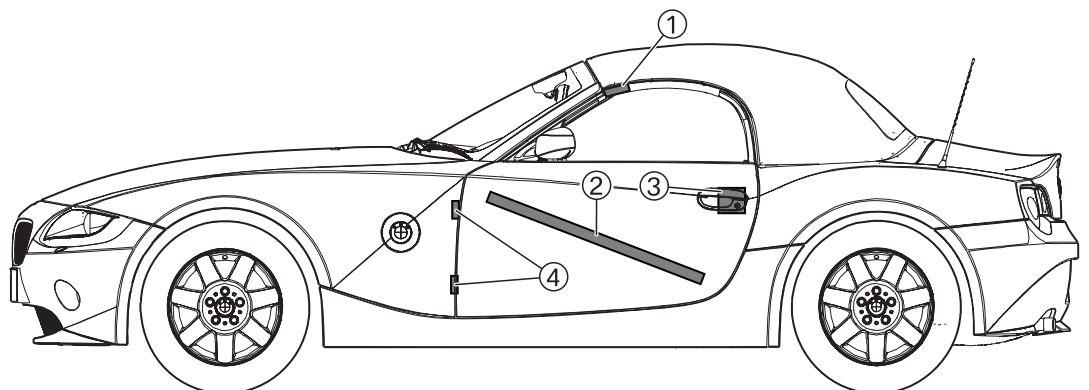

- 1 The windscreen frame is strengthened so the roof can be separated from the convertible top frame.
- 2 Side intrusion protection (diagonal)
- 3 Door locks
- 4 Door hinge

Series / installation drawings

Convertible

Z8 Roadster - E52

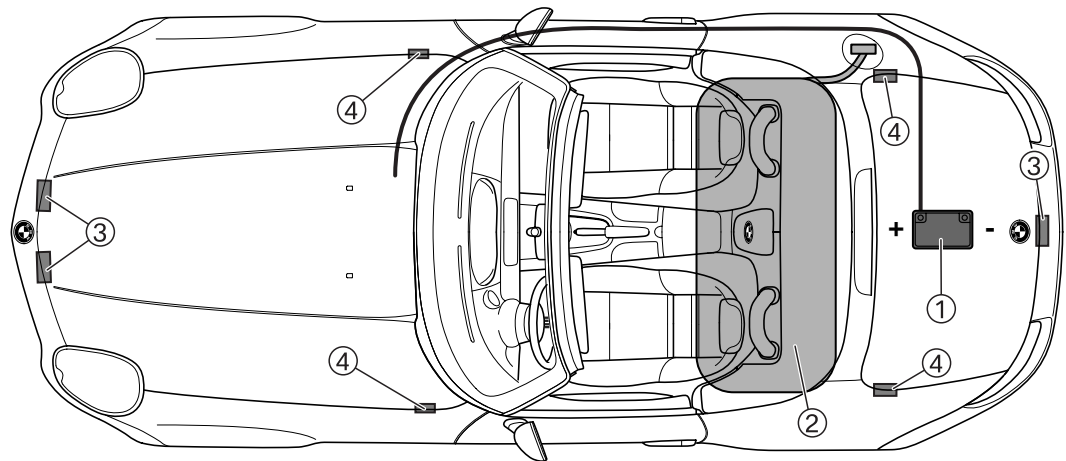

- 1 Battery
- 2 Fuel tank
- 3 Engine hood and luggage compartment locks
- 4 Engine hood and luggage compartment hinges

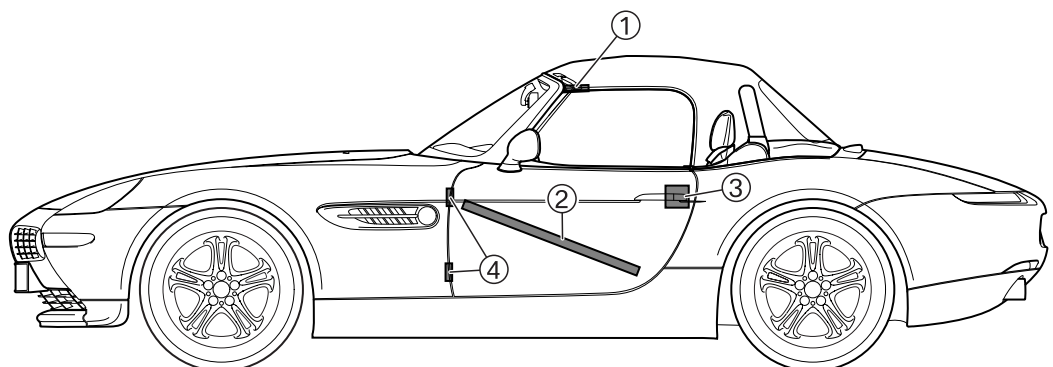

- 1 The windscreen frame is strengthened so the roof can be separated from the convertible top frame.
- 2 Side intrusion protection (diagonal)
- 3 Door locks
- 4 Door hinge

SUV - Sports Utility Vehicle

X3 - E83

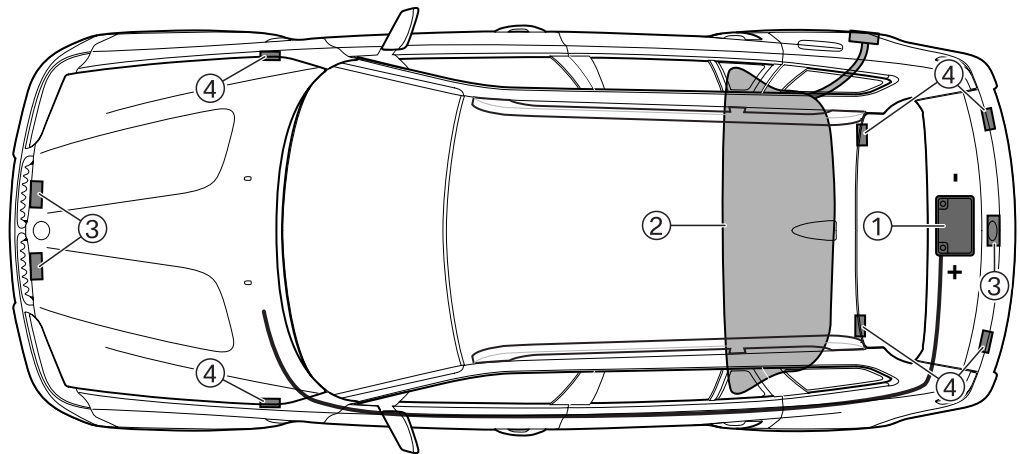

- 1 Battery (in the spare wheel recess)
- 2 Fuel tank
- 3 Engine hood and luggage compartment locks
- 4 Engine hood and luggage compartment hinges

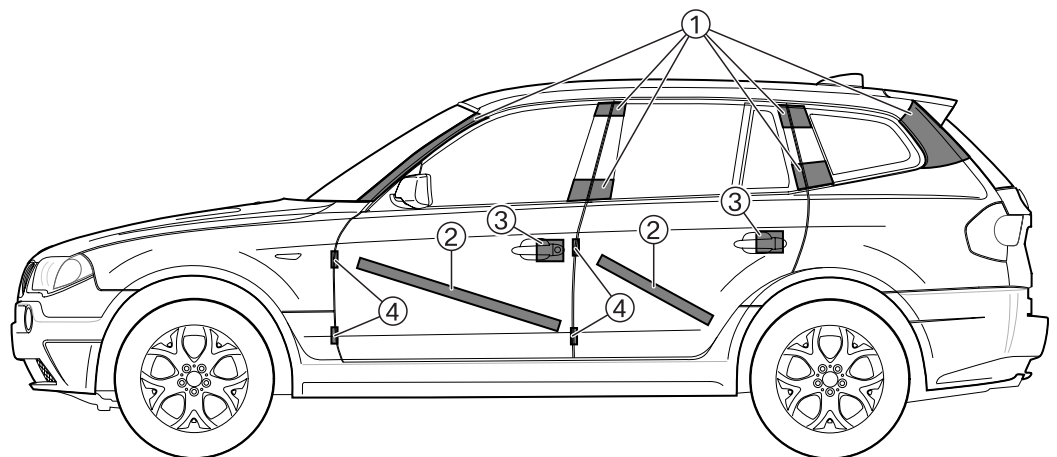

- 1 The surfaces indicate the areas from where the roof can be removed.
- 2 Side intrusion protection (diagonal)
- 3 Door locks
- 4 Door hinge

Series / installation drawings

SUV - Sports Utility Vehicle

X5 - E53

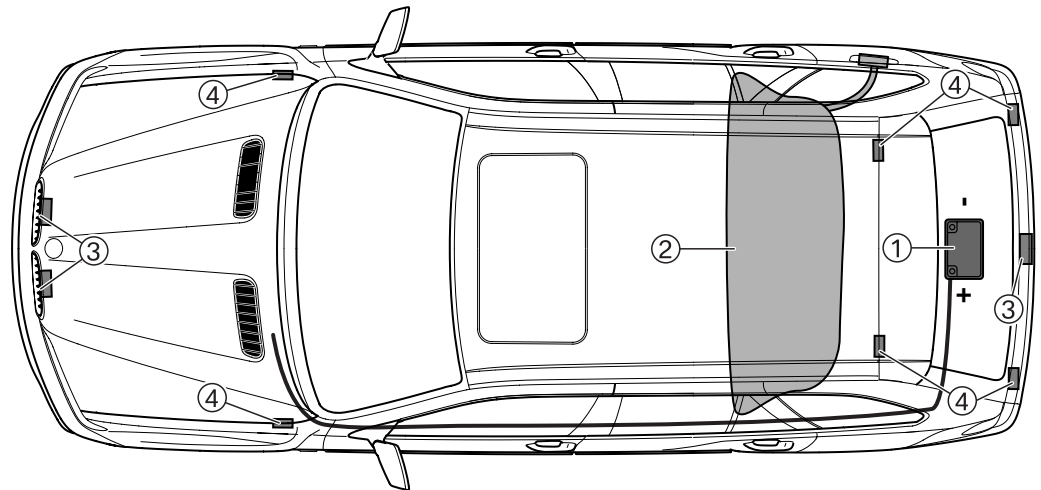

- 1 Battery (in the spare wheel recess)
- 2 Fuel tank
- 3 Engine hood and luggage compartment locks
- 4 Engine hood and luggage compartment hinges

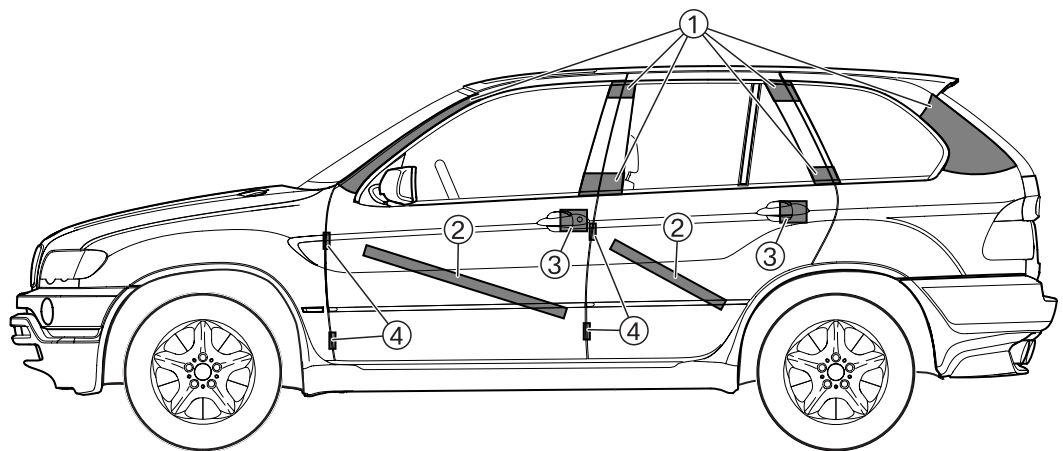

- 1 The surfaces indicate the areas from where the roof can be removed.
- 2 Side intrusion protection (diagonal)
- 3 Door locks
- 4 Door hinge

Series / installation drawings

MINI

MINI ONE R50
MINI Cooper R50
MINI Cooper S R53

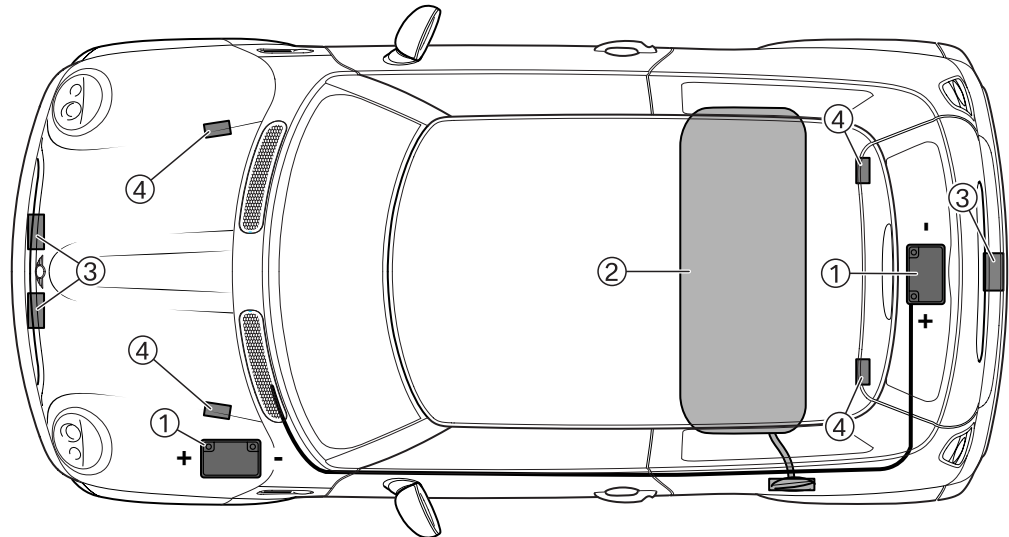

- 1 Battery (front left **or** rear centre)
- 2 Fuel tank
- 3 Engine hood and luggage compartment locks
- 4 Engine hood and luggage compartment hinges

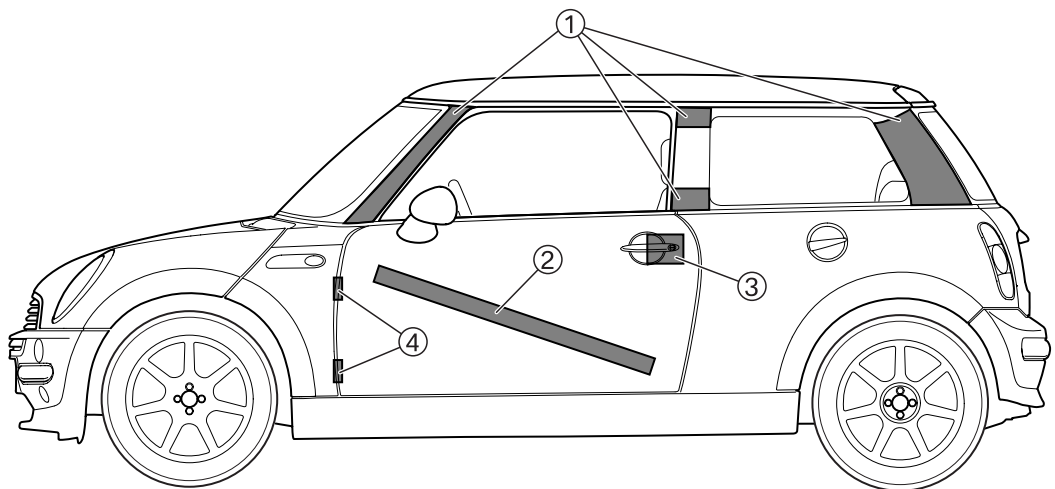

- 1 The surfaces indicate the areas from where the roof can be removed.
- 2 Side intrusion protection (diagonal)
- 3 Door locks
- 4 Door hinge

Series / installation drawings

MINI

MINI Convertible R52

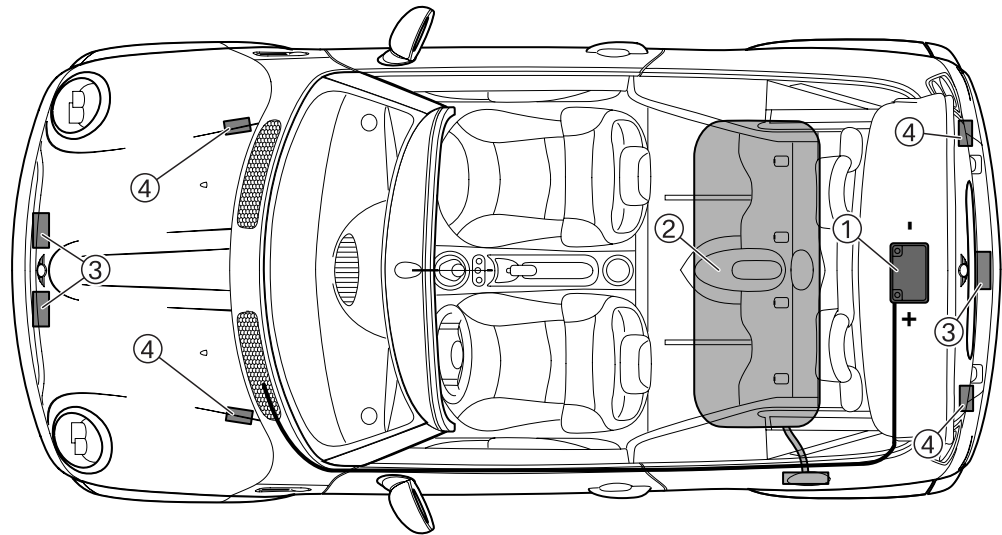

- 1 Battery
- 2 Fuel tank
- 3 Engine hood and luggage compartment locks
- 4 Engine hood and luggage compartment hinges

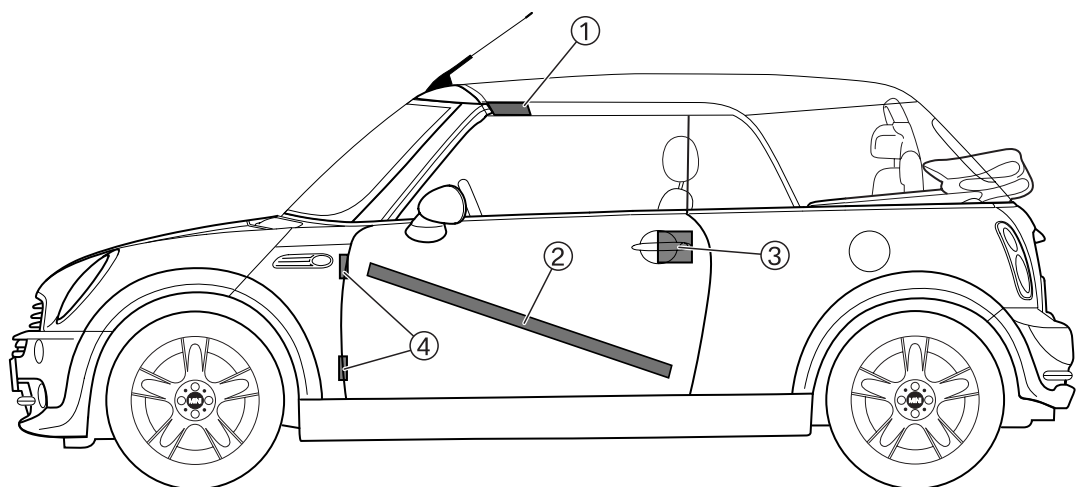

- 1 The surfaces indicate the areas from where the roof can be removed.
- 2 Side intrusion protection (diagonal)
- 3 Door locks
- 4 Door hinge

Tips for using rescue equipment

Jacking vehicles

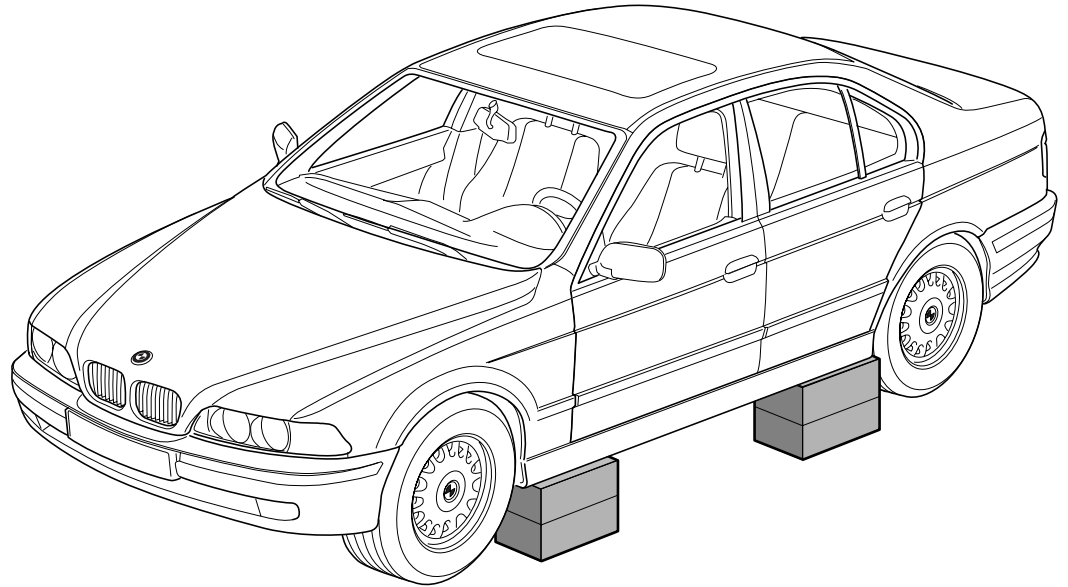

Jacking vehicles

The vehicles can be fitted with jacks under the entire side sill. Ideally, you should use the designated support ports for the jack.

Electric seat adjustment

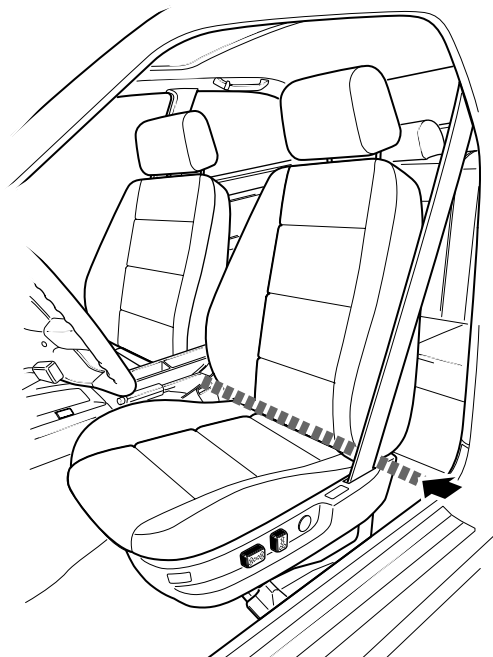

Seat with electric seat adjustment

Since electric seats can no longer be adjusted once the battery has been disconnected, removal is recommended at the marked area.

Tips for using rescue equipment

Opening vehicle doors

1st variant

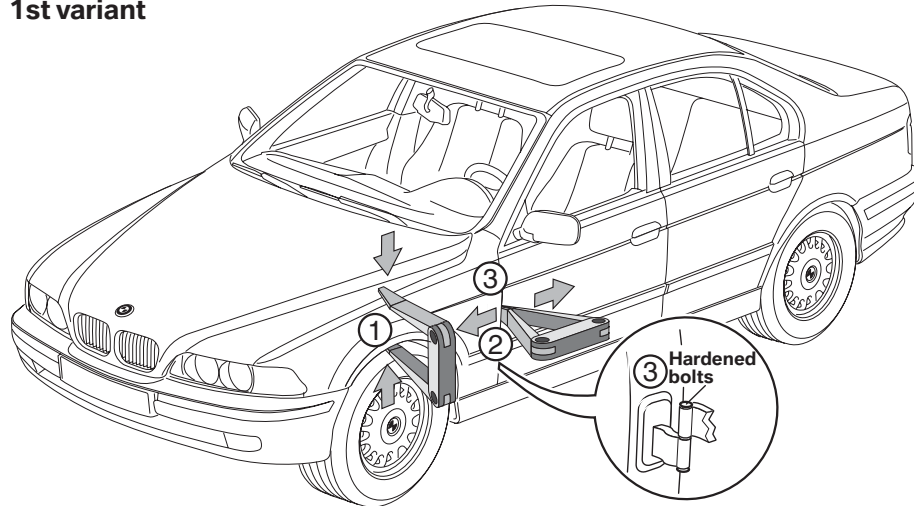

Starting points for opening doors at the A-pillar

- 1 Compress the fender with the hydraulic rescue spreader. This creates a bigger gap between the fender and the front door.
- 2 Then use the spreader to enlarge the gap at the height of the hinges (see the relevant vehicle model).
- 3 Cut off the hinges with the hydraulic cutters and open the door.

2nd variant

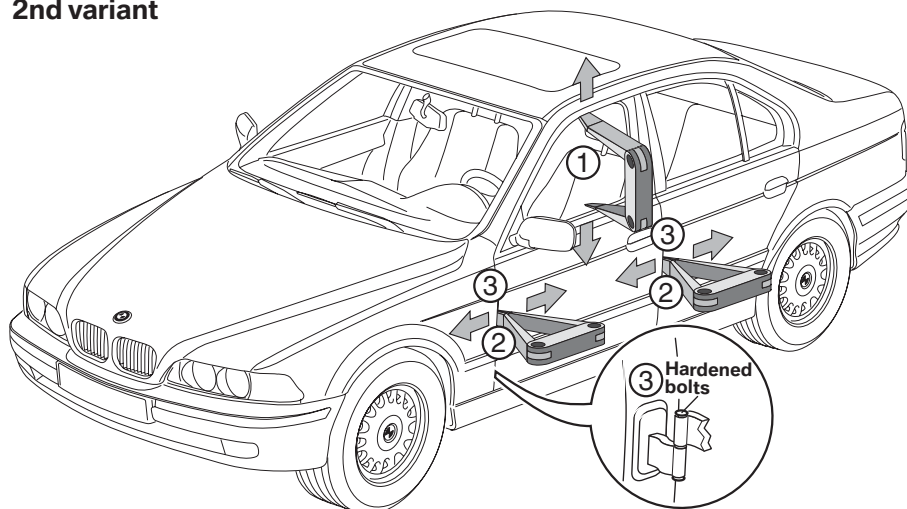

Starting points for opening doors at the A or B-pillar

- 1 Force the window apart with the hydraulic rescue spreader. This creates a bigger gap between the front door and the B-pillar or between the fender and the front door.
- 2 Use the spreader to enlarge the gap at the height of the hinges (see the relevant vehicle model).
- 3 Then open the door on the hinge or lock side (on the lock side on vehicles without horizontal side-impact protection, see the relevant vehicle model).

Tips for using rescue equipment

Pressing an instrument panel back

Newer models



1 Series (E87)



3 Series (E90)



5 Series (E60)



5 Series (E61)



6 Series (E63)



6 Series (E64)



7 Series (E65/66)

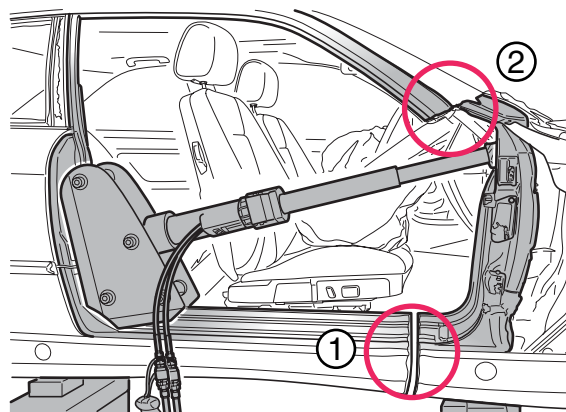

Pressing instrument panel back

- Secure the vehicle floorpan against buckling with supporting material
- Cut off the door at the hinges with the hydraulic cutters
- Cut the side sill (1) away from the passenger in the direction of the **floor** with the hydraulic cutters
- Cut through both A-pillars (2) with the hydraulic cutters
- Place the supporting bracket as illustrated on the B-pillar
- If possible, place the rescue cylinder between the centre mounting and the instrument panel, below the cut
- Press the front end back

Important

Rescue equipment can slip off.

Note

Install the supporting bracket if the rescue cylinder is too short. The procedure for pressing the front end back with the rescue cylinder is more suitable for the casualty than moving the steering column with the chain hoist.

Tips for using rescue equipment

Older models

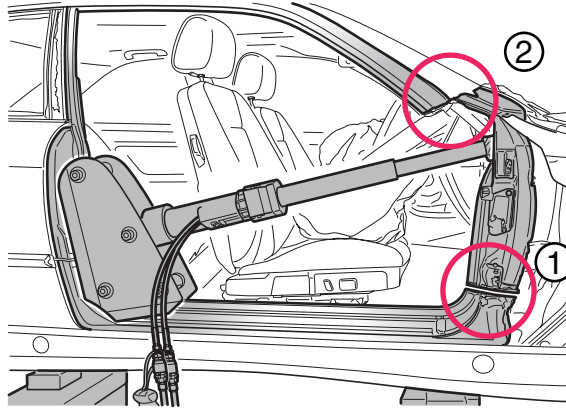

Pressing instrument panel back

All models except for 1 Series (E87), 3 Series (E90), 5 Series (E60, E61), 6 Series (E63, E64), 7 Series (E65/66)

- Secure the vehicle floorpan against buckling with supporting material
- Cut off the door at the hinges with the hydraulic cutters
- Cut the side sill (1) away from the passenger in the direction of the **front end** with the hydraulic cutters
- Cut through both A-pillars (2) with the hydraulic cutters
- Place the supporting bracket as illustrated on the B-pillar
- If possible, place the rescue cylinder between the centre mounting and the instrument panel, below the cut
- Press the front end back

Important

Rescue equipment can slip off.

Note

Install the supporting bracket if the rescue cylinder is too short. The procedure for pressing the front end back with the rescue cylinder is more suitable for the casualty than moving the steering column with the chain hoist.

Tips for using rescue equipment

Securing vehicles

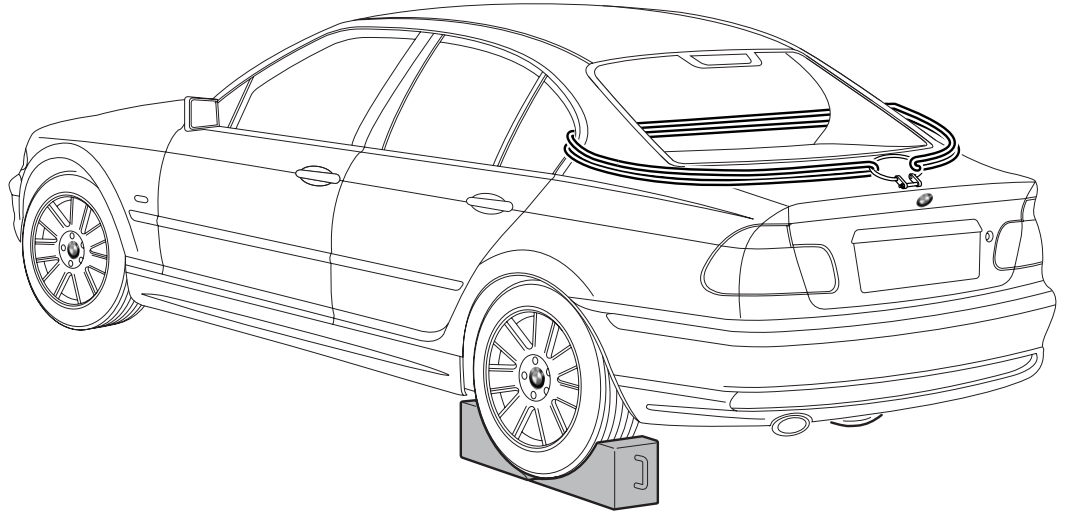

Securing options

Chock

Place a chock on the opposite side to where the vehicle is raised in front of and behind the wheel on the rear axle.

Endless sling

Feed the endless sling through the window openings to the rear or front and secure it to a suitable counter-support.

Front and rear axles

To secure the vehicle, always combine several axle components (axle carrier, steering arm, drive shafts).

Towing eye

Important

The towing eye must **not** be used to recover or secure the vehicle.

Technical information

Airbag

Use

Due to the different legislations in Europe and USA, various airbag variants are used in BMW vehicles:

- **Front airbag, driver I:** large air cushion in vehicles with standard equipment (the volume in the USA and EU varies as a result of legislation)
- **Front airbag, driver II:** small air cushion (compact airbag; Eurobag) in vehicles with equipment that includes a sports steering-wheel
- **Front airbag, passenger:** air cushion located beneath the instrument panel on the passenger side
- **Side airbag:** small air cushion located on the inside of the door frame (front and rear doors) or in the outer sides of the front seat
- **ITS head airbag:** air pipe fitted at the lower end of the A-pillar along the inner roof structure reaching to shortly before the C-pillar on the roof frame
- **AITIS head airbag:** integrated head airbag from the A-pillar to the C-pillar; expansion of the ITS head airbag by a canvas between the ITS airbag and the roof frame
- **Curtain airbag:** integrated head airbag from the A-pillar to the C-pillar; expanded covered area for the front and rear side windows
- **Rear head airbag:** small air cushion in the roof frame above the C-pillar
- **Knee airbag:** small air cushion behind the glove box flap or behind the steering column casing (only available in the US release)

Driver's airbag



Triggered driver's airbag

The driver's airbag is located in the impact absorber on the steering wheel. The acceleration is detected and evaluated by a sensor. If the triggering threshold is exceeded, the airbag control unit or the relevant satellite (= intelligent sensor) sends an ignition voltage to the ignition squib, which then triggers the airbag. The gas generated by the ignition escapes into the airbag, which then inflates completely.

Technical information

Passenger airbag

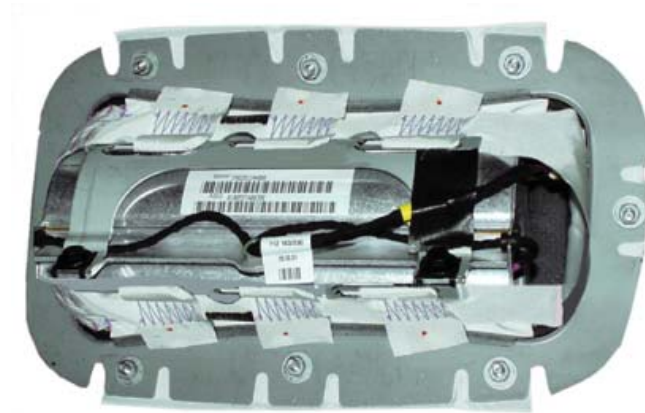

Passenger airbag that has not been triggered

The passenger airbag is located in the instrument panel above the glove box on the passenger side.

A seat-occupancy detector has been integrated for years in order to avoid unnecessary triggering of the passenger airbag in the event of a crash, when the passenger seat is not occupied.

The front passenger seat is identified as being occupied from a weight of 12 kg by the sensors in the front passenger seat and through evaluation of the data in the airbag control unit or in the satellite (= intelligent sensor) and the system is thereby activated.

Side airbag

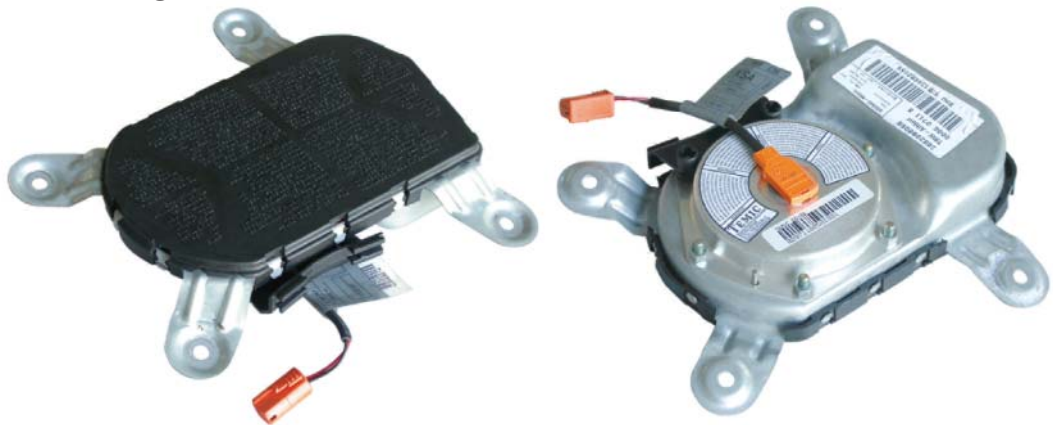

Side airbag that has not been triggered

In most BMW models, the side airbags are located behind the side trim panel in the door. In 1 Series and MINI models, the side airbags are located in the sides of the driver and front passenger seat backrests.

In the event of a side impact, the transversal acceleration that occurs is detected by appropriate sensors.

If the triggering threshold is exceeded, the airbag control unit or the relevant satellites (= intelligent sensors) fire the side airbags and, if fitted, also the head airbag.

Technical information

ITS head airbag



ITS not triggered (in roof area) and triggered

Unlike the other airbags, the ITS head airbag is a tubular system which is secured to the vehicle body with belt straps.

When the generator is fired, this increases the diameter of the head airbag, thereby reducing its overall length. This process causes the head airbag to stretch between the lower end of the A-pillar and the rear attachment to the roof frame.

Unlike front and side airbags, which collapse relatively quickly after inflating, the head airbag retains the gas volume and thus also offers protection in the event of the vehicle rolling over or secondary accidents.

The head airbag can be cut off at the belt straps or cut through safely.

AITS head airbag



AITS for front and rear-seat passengers (triggered)

The AITS head airbag is a head protection system like the ITS. It has the advantage of area protection similar to a curtain.

The AITS prevents the head and other limbs of the passengers from wobbling about. This in turn leads to less serious neck shear forces and head injuries.

Characteristics of the system:

- Expanded covered area for the front and rear side windows
- Protection against glass splinters and incoming objects
- Improved covered area even for very large passengers

Technical information

Curtain airbag

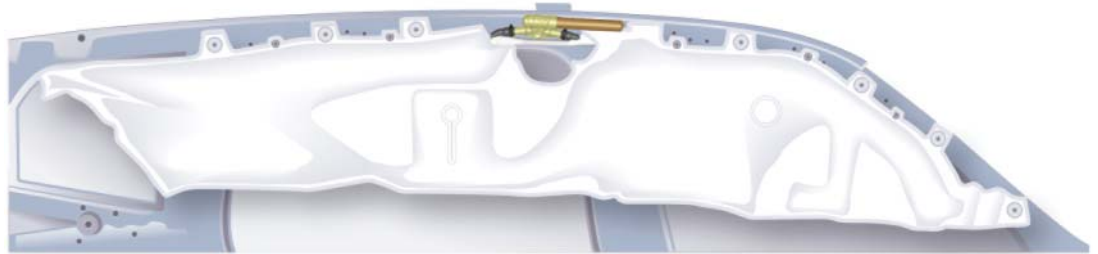

Curtain airbag triggered

The curtain airbag reaches from the A-pillar to the C-pillar and covers the entire side area. It inflates between the passengers, side window and the pillar trims.

Characteristics of the system:

- Expanded covered area for the front and rear side windows
- Protection against glass splinters and incoming objects
- Improved covered area for passengers of different sizes

The curtain airbag is stored uninflated in the area of the roof frame. It consists of the gas generator, the two gas lances and the curtain.

The generator is fired in the event of a side collision. The gas generated flows through the two gas lances into the curtain. If the curtains front and back are filled at the same time, a more even filling can be achieved.

By securing the curtain airbags to the A-pillar and C-pillar, the head airbag is brought into position. The curtain airbag then stretches between the side window, pillar trim and passengers. The structure rigidity and stability are maintained for several seconds as a result of the closed system.

Knee airbag



Knee airbag, driver's side (left) and passenger side (right)

In the event of an impact when the driver or front passenger is not strapped in, the knee airbag supports the knee.

A controlled forward displacement of the upper body is induced, which is absorbed by the relevant airbag.

The knee airbag on the driver's side is located beneath the steering column, behind a cover. The knee airbag on the passenger side is located in the glove box flap, behind a cover.

Technical information

Firing sequence

Airbags are triggered by the airbag control unit or the relevant satellites (= intelligent sensor). When the triggering limits are exceeded, the integrated sensors activate the required systems; in the gas generator, the solid propellant sodium azide or nitrocellulose burns mainly into nitrogen. Minute quantities of carbon monoxide and nitrogen oxide are produced. This gas then flows into the airbag and inflates it. When the airbag inflates, the cover (impact absorber of driver's airbag, cover of passenger airbag, trim of side / head airbags) splits open at the programmed rupture points.

The talc from the airbag that is deposited in the passenger compartment is completely safe.

Safety mechanisms

All models except for 1 Series (E87), 3 Series (E90), 5 Series (E60, E61), 6 Series (E63, E64), 7 Series (E65/66) and Z4.

The restraint and safety systems are triggered by way of electronic and mechanical acceleration sensors. **Two independently** operating sensors are always fitted to trigger the airbags.

Electronic acceleration sensors

Driver's and passenger airbags, head and side airbags, seat belt tensioners and safety battery terminal.

Mechanical acceleration sensor (Safing sensor)

Driver's and passenger airbags are triggered in conjunction with the mechanical acceleration sensors.

Electronic side-impact sensors

Side and head airbags are triggered in conjunction with the electronic acceleration sensors.

Airbag control unit

The airbag control unit is the central unit of the entire restraint and safety system and assumes the following functions:

- Crash detection
- Determining igniter timing for airbags, seat belt tensioners and safety battery terminal
- Ignition of airbags, seat belt tensioners and safety battery terminal
- Self-test
- Fault indication and fault memory with diagnostic capabilities
- Seat-occupancy and weight detection of front passenger seat

Satellites

Satellites consist of a control unit with an integrated sensor system to trigger actuators (airbags, belt tensioners, etc.). Satellites are able to make intelligent decisions to trigger actuators selectively and quickly. Unnecessary functions are not activated.

The 7 Series models (E65/E66) are fitted with the Intelligent Safety and Integration System (ISIS) and the 5 Series (E60/E61), 6 Series (E63/E64) and Z4 (E85) onwards are fitted with the Advanced Safety Electronic (ASE) system with satellites.

Technical information

Seat belt tensioner

Four different seat belt tensioner systems are used in the vehicles:

- Mechanical seat belt tensioners
- Pyrotechnic seat belt tensioners
- Pyrotechnic inertia reel tensioners / anchor-fitting tensioners
- Seat-integrated seat belt system SGS

All systems have the same objective, to reduce belt slack which subjects the human body to a biomechanical load after an accident.

Pyrotechnic inertia reel tensioner / anchor-fitting tensioner

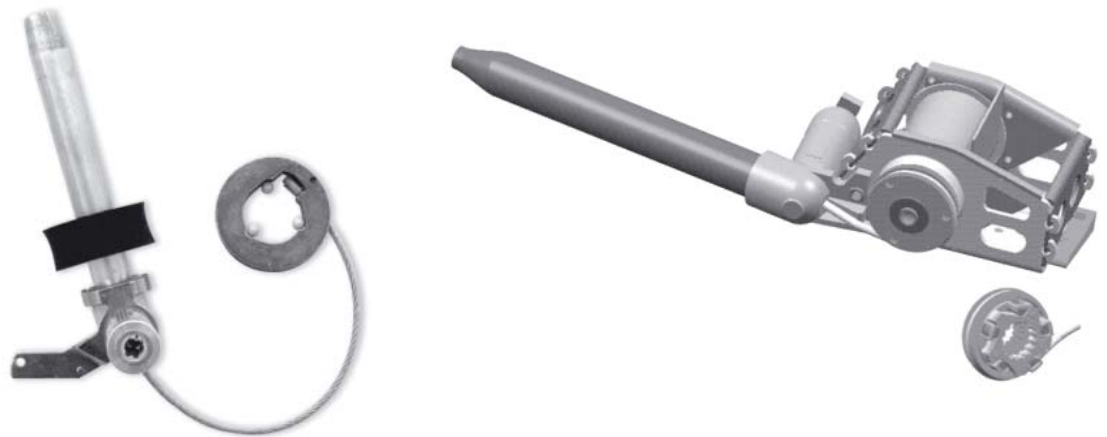

Pyrotechnic inertia reel tensioner

Pyrotechnic anchor-fitting tensioner

With a pyrotechnic inertia reel tensioner, the belt slack is reduced by friction in the belt guides, especially in the shoulder area.

A pyrotechnic propellant charge is fired via sensors and control electronics, which begins the inertia reel shaft rotation by means of a wound-up Bowden cable.

To rectify the film spool effect, there is a clamping fixture to hold the seat belt secure in the event of the occupant being moved forward.

The pyrotechnic anchor-fitting tensioners can currently only be fitted to the outer seats in the rear area.

Due to the lack of space beneath the back seat, a solution such as the front seat belt tensioner is not possible. The belt slack is therefore removed by retracting the seat belt strap at the end fitting. The automatic reel forms the upper attachment point and the anchor-fitting tensioner forms the lower.

The anchor-fitting tensioners are fired by the seat satellites or the seat module, a pyrotechnic unit tightens the seat belt.

Technical information

Mechanical seat belt tensioner



Mechanical seat belt tensioner

With the mechanical seat belt tensioner, a mechanical sensor detects the impact and triggers the release of the tensioner energy via a switch mechanism. With an element of force transmission, the seat belt buckle is pulled down diagonally and the seat belt strap is therefore tightened across the body of the passenger. With the subsequent build-up of the belt force, a locking system locks the seat belt buckle into each tensioning position. The passenger is therefore joined more effectively to the vehicle.

In the event of a head-on collision, the mechanical impact sensor activates the system. A preloaded spring pulls the seat belt buckle back. Shoulder and lap-only belts are tensioned.

Pyrotechnic seat belt tensioner



Pyrotechnic seat belt tensioner

To reduce the belt slack even more quickly, the pyrotechnic seat belt tensioner is an updated version of the mechanical seat belt tensioner.

The pyrotechnic seat belt tensioners are fired by the airbag control unit or the seat satellites, a pyrotechnic unit tightens the seat belt.

Technical information

Seat-integrated seat belt system (SGS)



Seat-integrated seat belt system (SGS)

With the seat-integrated seat belt system (SGS), all belt elements including the guide points are located in the seats. In the event of an impact, all forces are passed into the floor assembly on vehicles without a B-pillar.

Furthermore, the head restraint and upper belt guide point are automatically adjusted, depending on the longitudinal seat adjustment.

An upper seat belt tensioner located directly on the upper belt outlet also restricts passenger displacement in the event of an impact. The whole system reduces the free seat belt lengths to a minimum.

Because all three belt points move when the seat is adjusted, the belt geometry automatically guarantees the best possible position of the belt around the body regardless of seat position and body size.

Active head restraint



Active head restraint

Active head restraints can currently only be installed in 7 Series (E65/66) models. These are integrated into the driver's and passenger seats.

Function

In the event of a rear crash, the head nods backwards because it becomes the most sluggish part of the body due to the too-large distance between the head and the head restraint. This nodding movement can cause cervical vertebra injuries (whiplash).

To reduce the distance between the head and the head restraint, the active head restraint tilts forwards towards the head in the event of a rear crash.

In the event of a rear-end collision, the gas generator in the seat back is activated by two additional crash sensors or satellites in the vehicle rear end. The piston rod of the gas generator then shifts a sliding piece. This sliding piece moves the support tube, to which the head restraint is secured, forwards and therefore reduces the distance between the head and the head restraint.

There is an adjustment path of between 40 and 60 mm, depending on the height adjustment of the head restraint.

Technical information

Rollover protection system

The rollover protection system is only installed in 3 Series (E36, E46) convertible models and 6 Series (E64) models. Stationary roll bars are fitted in the other convertible models.

The rollover protection system is an additional safety function in some BMW convertible models. In the event of a rollover or other situations which can cause a rollover, the rollover protection system extends, engages with positive locking and therefore supports the preservation of a sufficient survival margin for the passengers.

Function - 3 Series E36 and E46

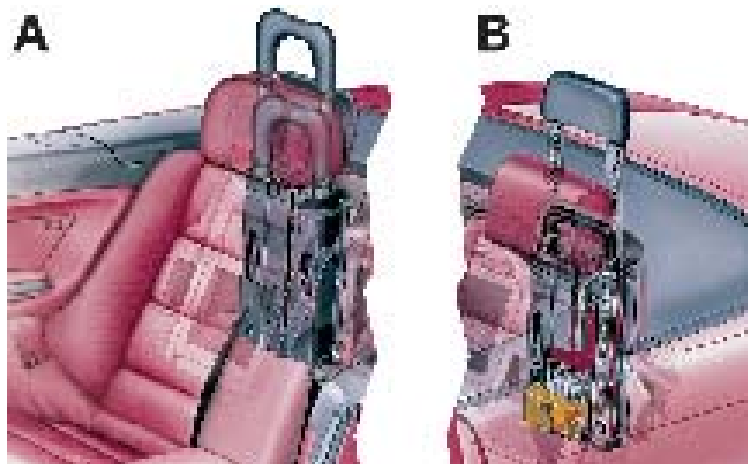

Triggered rollover protection system for 3 Series E46 (A) and E36 (B) Convertible

The rollover protection system consists of two rollover bars behind the rear-seat head restraints in 3 Series (E36) models (visible) and two rollover bars in the rear-seat head restraints in 3 Series (E46) models (concealed).

The rollover protection system is a separate system and is not connected in any way to the airbag control unit.

The rollover sensor is bolted directly to the protective cover behind the right rear bench seat.

The rollover sensor comprises:

- a level sensor to detect tilt angle, lateral and longitudinal acceleration
- a g-sensor (g = gravitation) to detect loss of contact with the road surface
- an electronic evaluation unit with self-diagnosis
- two condensers to provide reserve energy required to trigger the protective bar should the on-board supply voltage fail

The integrated rollover sensor gives the actuator the command to release the locks when the values are reached. An electromagnet actuates the lock and releases the spring-loaded roll bar. The rollover bars are extended and locked mechanically in their end position.

Function - 6 Series E64



Rollover protection device for the 6 Series E64 in normal position and triggered (right)

In the 6 Series (E64) models, the two extendable protective bars are located behind the two rear seats in a carrier structure.

The rollover protection system is a separate system and is not connected in any way to the airbag control unit.

Unlike the rollover protection system of the 3 Series Convertibles E36 and E46, the rollover sensor is located in one of the satellites.

In normal operating mode, the protective bars are introduced into the carrier structure. The protective bars are tensioned by a spring in the direction in which they are pulled out and held by the catch on the actuator.

If an imminent rollover is detected by the rollover sensor in the satellite, the data is sent via a light-oriented bus system to the safety and gateway module SGM. At the same time, the signal to release the rollover protection system is sent to the SGM via a copper line (arming line). This activates the two actuators via an output stage. The protective bars are extended by a spring force.

Safety battery terminal



Safety battery terminal

Function

The safety battery terminal is bolted directly onto the positive terminal of the battery.

In order to minimise the risk of short circuit in accidents, the vehicle's system in BMW vehicles is divided into two power circuits: the power supply for vehicle systems and the starter power circuit.

If, in the event of an accident, the decisive criteria are fulfilled, the airbag control unit or one of the satellites sends the command to fire the propellant charge in the safety battery terminal. The generated gas volume forces the lead pin out of its mount in the battery terminal, thereby disconnecting the lead connection between battery and starter / alternator.

The remaining electrical loads continue to be supplied with voltage by way of a separate battery connection (power supply for vehicle systems).

The entire triggering sequence takes place in approximately 3 ms.

Important

The safety battery terminal only disconnects the positive battery lead between the battery and starter / alternator. In order to de-energise the protection systems, you must disconnect both battery leads (negative and positive) from the battery.

Frequently asked questions

How does an airbag function?

The acceleration detected by the sensors is integrated and evaluated. The required airbag is fired once the appropriate triggering thresholds have been exceeded. The squib in the gas generator receives the firing voltage from the airbag control unit or from the relevant satellite. The generated gas escapes into the airbag.

How can you tell whether a vehicle is fitted with airbags?

AIRBAG or SRS or SRS-AIRBAG label on the steering wheel, dashboard, door panel and A-pillar trim panel, C-pillar, outer side of the driver and front passenger seat backrest. If in doubt, assume that newer vehicles will be fitted with airbags.

Is smoke discharged during the firing process?

There is generally a build-up of dust due to the talcum powder with which the airbag is coated at the factory.

Does the airbag get hot?

The airbag does not get hot. Only the components inside the airbag module reach high temperatures when the airbag is triggered. These components are located in the area of the airbag mounting and do not pose any danger to the rescuers. The parts take approximately 15 minutes to cool down.

Can traces of sodium azide be found in the residues?

Sodium azide, the solid propellant in the gas generator, burns up completely when the gas generator is fired and is chemically converted up to 100%. The reaction product consists primarily of harmless nitrogen, which makes up approximately 80% of the air we breathe.

What precautions must be taken if an untriggered airbag module is damaged mechanically?

In the extremely unlikely event of the airbag gas generator being destroyed, the propellant compressed into tablet form could fall out. In this event, it is absolutely essential to avoid skin contact (wear gloves and protective goggles). The tablets must be handled and disposed of separately from normal waste. They must be kept away from all ignition sources (electricity, fire, etc.).

In the event of a vehicle fire, is there a danger of the airbag generator exploding?

The gas generator is designed in such a way that it triggers normally if exposed to a fire when the surface temperature of the gas generator exceeds 200 °C.

Can water be used to extinguish a fire?

Yes. Every effective fire-extinguishing agent can also be used on vehicles equipped with airbags.

Is it safe to breathe the air in the passenger compartment after an airbag has been triggered?

Yes. Chemical and medical analyses have confirmed this to be safe. However, short-term skin irritation may occur.

If the airbag was not triggered in the crash, is it likely to be triggered after the crash?

No. The crash sensors react to the physical characteristics of an accident.

Frequently asked questions

Is there a danger to persons administering first aid?

No. A person administering first aid (a helper without life-saving equipment) will encounter the same situation as in normal mode. When a vehicle is stationary, the airbag systems will not be triggered.

If the airbag was not fired in the crash, how can the system be deactivated?

Turn off the ignition, then disconnect **both** battery leads (first negative and then positive) from the battery.

This eliminates the risk of an airbag being triggered during the rescue operation. Exceptions, see the "Airbag" chapter.

Should the rescue personnel wait until the airbag system is deactivated before continuing the rescue operation?

No. Turn off the ignition, then disconnect **both** battery leads (first negative and then positive) from the battery.

Once the points on the subject "Response of restraint and safety systems after an accident" have been heeded, you can begin to save the passengers immediately.

How should you react when persons are trapped, individual airbag systems have not been triggered and the vehicle cannot be de-energised?

- Initiate emergency medical measures immediately.
- Create openings for tending to the trapped persons as a matter of priority.
- Check: Which airbag systems in the vehicle have not yet been triggered and are located in the areas where the rescue personnel are working?
- If at all possible, do not pull the steering column with the spreader.
- Do not cut through any cables in the area of the airbag systems (there is a small risk of airbags being triggered as a result of a short circuit).
- Initiate measures to protect the injured persons in the inflation area of an untriggered airbag.
- Tend to injured persons from the side.
- If at all possible, do not move your head or upper body into the operating area of the airbag if heavy rescue equipment is being used on the vehicle.