

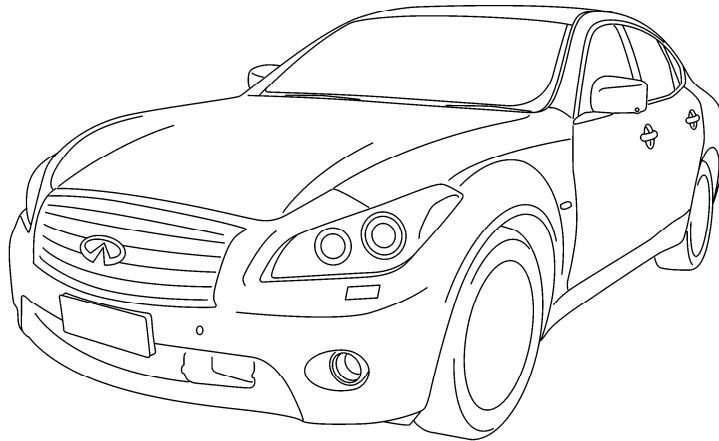

INFINITI®

INFINITI Hybrid vehicle First Responder's Guide

Infiniti Q50 Hybrid, Q70 Hybrid and Infiniti M35h



Foreword

This manual describes first response operations and related warnings and cautions for this vehicle.

This vehicle is equipped with a high voltage Lithium-ion (Li-ion) battery pack. **Improper rescue techniques may result in death or serious personal injury.**

Please read this manual in advance in order to understand the features of this vehicle and to help you deal with incidents involving this vehicle. Follow the procedures in order to help assure a successful first response operation.

IMPORTANT INFORMATION ABOUT THIS MANUAL

You may see various symbols in this manual. They have the following meanings:

DANGER

This symbol is used to inform you of an operation which will result in death or serious personal injury if instructions are not followed.

Example: Touching high voltage components without using the appropriate protective equipment will result in electrocution.

WARNING

This symbol is used to inform you of an operation which may cause death or serious personal injury if instructions are not followed.

CAUTION

This symbol is used to inform you of an operation which may cause personal injury or component damage if instructions are not followed.

Please note that there may be differences between this manual and the vehicle specification due to specification changes.

Table of Contents

Foreword.....	2
IMPORTANT INFORMATION ABOUT THIS MANUAL.....	2
1. HYBRID IDENTIFICATION.....	5
1-1 Exterior and Engine Compartment.....	5
1-2 Interior.....	6
1-3 Vehicle Identification Number (VIN) Layout.....	6
2. Basic High Voltage System and 12V System Information.....	7
2-1 High Voltage-Related and 12V-Related Component Locations and Descriptions.....	7
2-2 Battery Information.....	9
2-2.1 Low Voltage Battery.....	9
2-2.2 Li-ion Battery.....	9
2-2.3 Li-ion Battery Specification.....	10
2-2.4 Li-ion Battery Recycling.....	10
The high voltage battery is recyclable. For information regarding recycling of the high voltage battery, contact the nearest Infiniti retailer or Nissan/Infiniti customer assistance.....	
2-3 High Voltage Safety System.....	10
2-4 High Voltage Safety Measures.....	12
2-4.1 Warning Label.....	13
2-5 High Voltage Circuit Shut-Off System.....	13
2-6 Preventing Electrical Shock.....	13
3. Emergency Response Steps.....	14
3-1 Preparation Items.....	15
3-2 Vehicle Immobilization and Stabilization.....	16
3-3 How to Handle a Damaged Vehicle at an Accident Scene.....	17
3-3.1 Water Submersion.....	17
3-3.2 Vehicle Fire.....	17
3-3.3 High Voltage System Shut-Down Procedure.....	17
3-3.4 Cutting the Vehicle Body.....	28
3-3.5 Li-ion Battery Damage and Fluid Leaks.....	31
3-3.6 Accessing the Occupants.....	32

4. Roadside Assistance	33
4-1. Jump Starting	33
4-1.1 Jump Starting Procedures	34
4-2 Towing	36
4-2.1 Vehicle Specifications	36
4-2.2 Towing Guidelines	36
4-2.3 Use of Vehicle Equipped Hook for Recovery Operations	38
4-3 Storing the Vehicle	39
4-4 Jack, Tools and Spare Tire	40
4-5 Shift Selector Lever Lock Release	40
4-6 Opening the Fuel Filler Door	40
5. Storing the Vehicle	41

1. HYBRID IDENTIFICATION

1-1 Exterior and Engine Compartment

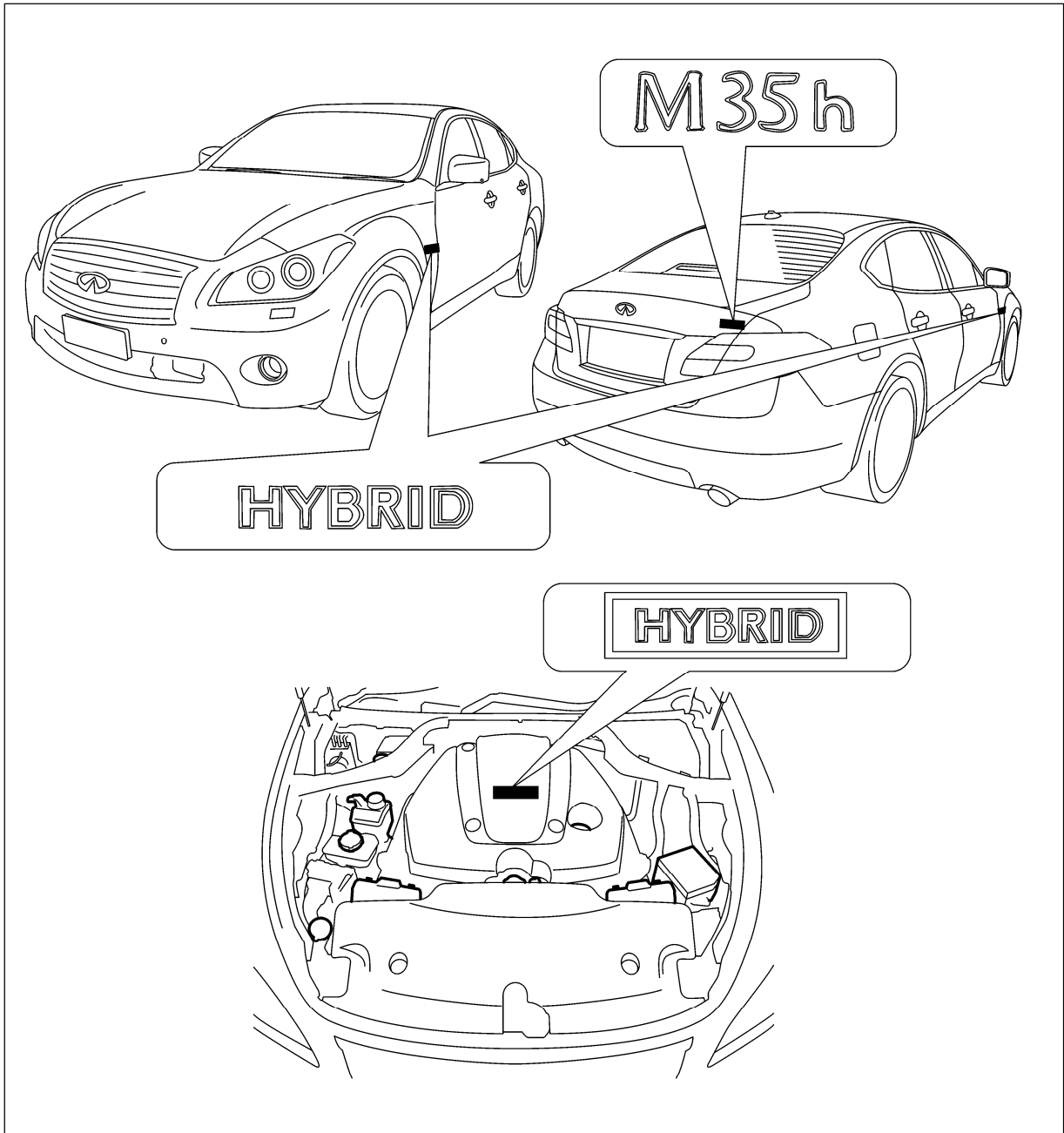

1-2 Interior

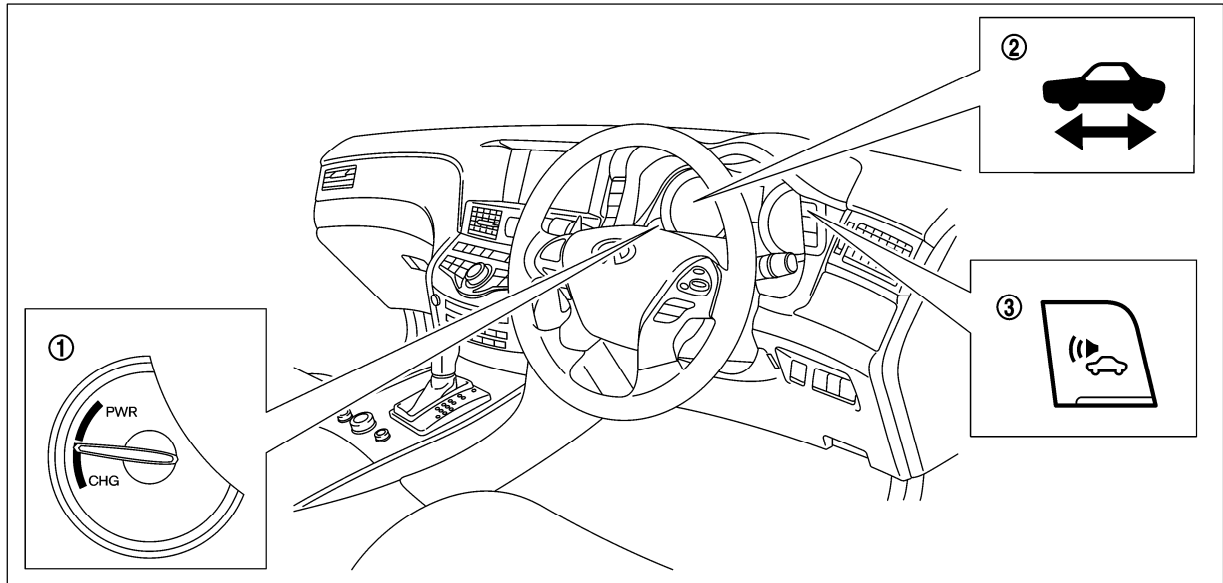

1. Assist charge gauge 2. READY indicator 3. VSP OFF switch

1-3 Vehicle Identification Number (VIN) Layout

In exterior appearance, a HYBRID is nearly identical to the conventional INFINITI vehicles.

Example VIN Q70 / M35h: JN1BEAY51U0552300, Q50: JN1BAAV37A0330006

A HYBRID is identified by the 5th alphanumeric character

Q70 / M35h: E, Q50: A

E / A = Hybrid vehicle(VQ35HR engine and HM34 motor)

The vehicle identification number can be located as follows:

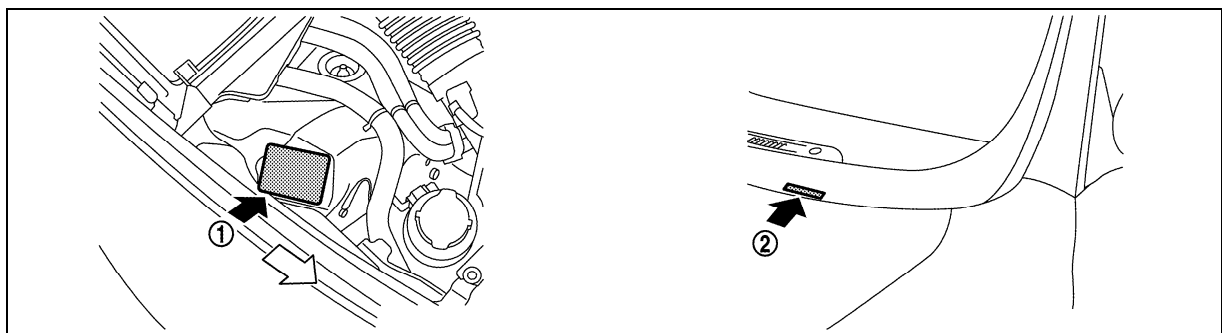

1. Vehicle Identification PLATE

2. VIN plate (visible through windshield)

2. Basic High Voltage System and 12V System Information

Infiniti HYBRID uses a hybrid system with maximum voltage of approximately 400V direct current (DC).

2-1 High Voltage-Related and 12V-Related Component Locations and Descriptions

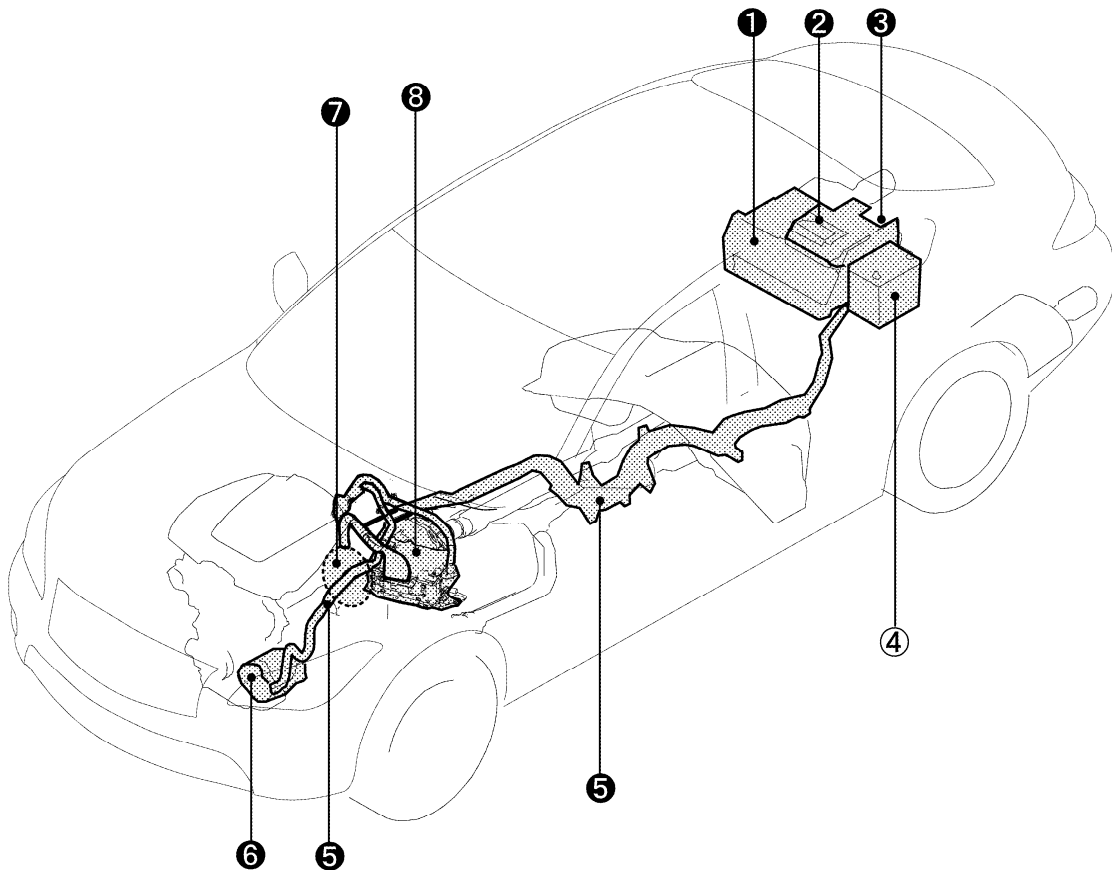

NOTE:

Components with white number in black background are high voltage components.

No.	Component	Location	Description
①	Lithium-ion (Li-ion) Battery	Trunk area (behind rear seat back)	The Li-ion battery stores and outputs DC power (Maximum voltage 400V) needed to propel the vehicle.
②	DC/DC Converter	Trunk area (mounted to top of Li-ion battery)	The DC/DC converter reduces the voltage of the Li-ion battery to provide power to the 12V battery in order to operate the vehicle's electric components (headlights, audio system, etc.).
③	Service Plug	Trunk area (below parcel shelf; behind access door in trim panel)	This is used to disable the high voltage system.
④	12V Battery	Trunk area (below parcel shelf; behind trim panel left of Li-ion battery)	A lead-acid battery that supplies power to the low voltage devices. Q50: 12V battery located on LHS in trunk compartment
⑤	High Voltage Harnesses	Trunk area (on Li-ion battery), under floor pan, engine compartment	Orange-colored power cables carry high DC voltage between each of the high voltage components.
⑥	Electric Air Conditioner Compressor	Engine compartment (front driver side)	Air conditioner compressor
⑦	Traction Motor	Built-into the transmission	Converts three-phase alternating current (AC) power to drive power (torque) which propels the vehicle.
⑧	Traction Motor Inverter	Engine compartment (rear passenger side)	Converts the DC power stored in the Li-ion battery to three-phase AC power and controls motor torque (revolution) by regulating the motor current.

2-2 Battery Information

Infiniti HYBRID utilizes two batteries in order to supply both high and low voltage.

2-2.1 Low Voltage Battery

The HYBRID contains a conventional lead-acid 12 volt DC low voltage battery. The low voltage battery is located in the trunk on the left side of the Li-ion battery and is concealed by a trim cover. The negative (-) 12 volt battery cable can be accessed through service access cover-1.

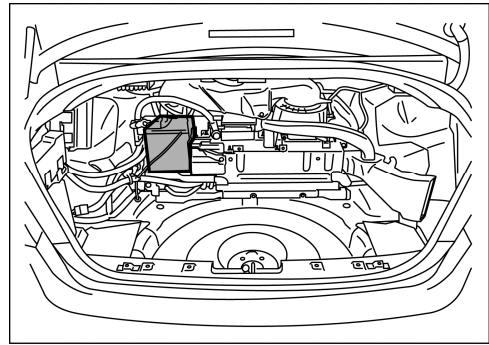

The 12 volt battery powers the vehicle's 12 volt electrical system, similar to a conventional vehicle. As with conventional vehicles, the 12 volt battery is grounded to the metal chassis of the vehicle. However, the 12 volt battery is charged by the Li-ion battery through the DC/DC converter.

2-2.2 Li-ion Battery

The HYBRID contains a Li-ion high voltage battery. The Li-ion battery is enclosed in a metal case, which is isolated from high voltage. It is mounted in the trunk area behind the rear seat and is concealed by a trim cover.

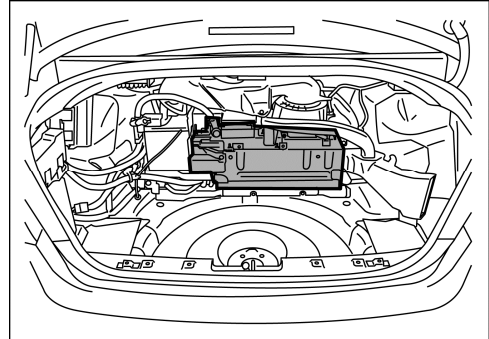

The Li-ion battery powers the vehicle's high voltage electrical system. The high voltage battery consists of 12 low voltage (28.8 volt) Li-ion battery modules connected in series to produce approximately 346 volts DC (400V max.). In the unlikely event that the high voltage battery is overcharged, the modules vent gases directly outside the vehicle through a vent hose.

An air vent is located on the rear parcel shelf (Q70 / M35h) or between the rear seat and the rear doors (Q50) to cool the high voltage battery. If the vent is covered, the battery will overheat,

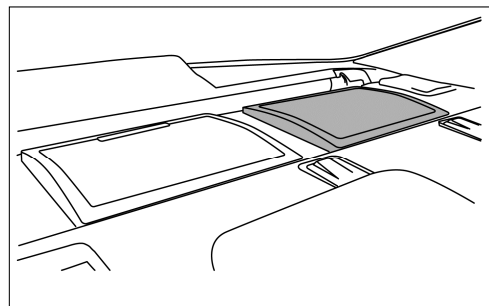

resulting in reduced output performance of the hybrid system.

Li-ion Battery Specifications	
Li-ion battery voltage	346V (400V max.)
Number of Li-ion battery modules in the pack	12
Li-ion battery module voltage	28.8V each

2-2.3 Li-ion Battery Specification

The high voltage battery supplies power to the following:

- High voltage harnesses
- DC/DC converter
- Traction motor inverter
- Traction motor
- Electric air conditioner compressor

2-2.4 Li-ion Battery Recycling

The high voltage battery is recyclable. For information regarding recycling of the high voltage battery, contact the nearest Infiniti retailer or Nissan/Infiniti customer assistance



2-3 High Voltage Safety System

The high voltage safety system is intended to help keep vehicle occupants and emergency responders safe from high voltage electricity.

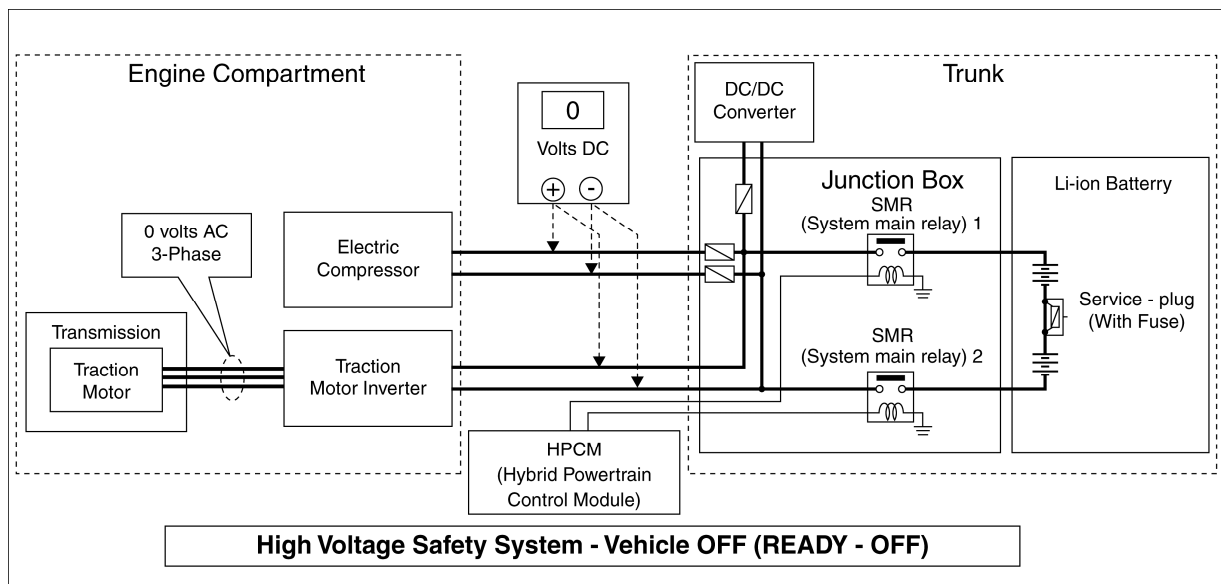
- A high voltage fuse provides short circuit protection inside the high voltage battery.
- The high voltage safety system is insulated from the metal chassis.
- Positive and negative high voltage power cables are connected to the high voltage battery and are controlled by normally open system main relays (SMR1 and SMR2). When the vehicle is shut off, the relays stop electrical flow from leaving the high voltage battery. However, it can take up to ten (10) minutes for the high voltage condenser to fully discharge.



DANGER

-  The high voltage system and condenser may remain powered for up to 10 minutes after the vehicle is shut off.
-  The high voltage battery retains high voltage at all times.

- A ground fault monitor continuously monitors for high voltage leakage to the metal chassis while the vehicle is running. If a malfunction is detected, the HPCM will illuminate the hybrid system warning light in the instrument cluster.
- The high voltage battery relays (SMR1 and SMR2) will automatically open to stop the electrical flow in a frontal collision that is sufficient enough to activate the supplemental restraint system (SRS).

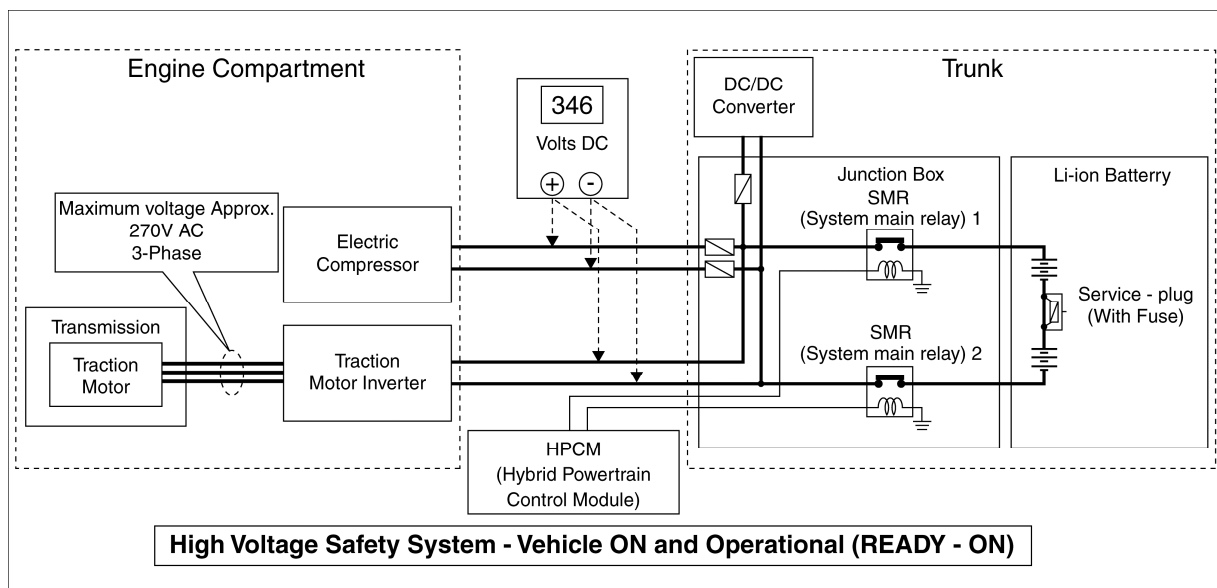



2-4 High Voltage Safety Measures







Circuit insulation	The high voltage positive (+) and negative (-) circuits are insulated from the metal chassis.
Reducing the risk of electrocution	The high voltage components and harnesses have insulated cases or orange-colored coverings which provide easy identification and insulation. The high voltage case is electrically connected to the vehicle ground. This connection helps protect the vehicle occupants and emergency responders from high voltage electrical shock.
Identification	The high voltage components are labeled "WARNING" as shown below. All high voltage harnesses are coated in orange.

3. Emergency Response Steps





DANGER

-  Failure to properly shut down the high voltage electrical system before the Emergency Response Procedures are performed will result in serious injury or death from electrical shock. To prevent serious injury or death, DO NOT touch high voltage harnesses or components with bare hands.
-  If it is necessary to touch any of the high voltage harnesses or components please wear appropriate PPE to avoid electrical shock. Shut down the high voltage system by following the steps outlined in [3-3.3 High Voltage System Shut-Down Procedure](#).

WARNING

-  NEVER assume the HYBRID is shut OFF simply because it is quiet.
-  If it becomes necessary for the rescuer to leave the vehicle, place a "DANGER" sign (for example, refer to [5. Storing the Vehicle](#)) on the vehicle to alert other people that the vehicle contains a high voltage battery.
-  If the READY  indicator is ON the high voltage system is active.
-  If possible be sure to check the READY  indicator on the instrument cluster and verify that the READY  indicator is OFF and the high voltage system is stopped.

3-1 Preparation Items

Preparation Items	Specification	Purpose
PPE (personal protective equipment): Insulated gloves  Insulated shoes  Safety shield 	Comply with EN60903 Use protective gloves made of insulating material. The protective gloves and shoes must be capable of resisting the voltage of 600 or more.	For protection from high voltage electrical shock
	Comply with EN166	
Wrenches 	Size:10mm	To remove the 12V battery terminal bolt.
Heat proof, solvent resistant protection gloves and shoes	Heat proof, solvent resistant protection tools	To utilize in the event of a Li-ion battery electrolytic solution leak.
Absorbent pad	The same pad used for internal combustion engine fluids can be used.	To absorb any Li-ion battery electrolytic solution leakage.
Extinguisher	Type ABC For electrical fires caused by the electrical harnesses and components, etc. and oil fires.	To extinguish a fire.
Insulated tape	Insulating	To cover the damaged harnesses to protect from and prevent electrical shock. Tape should cover all bare or damaged wire.

3-2 Vehicle Immobilization and Stabilization

Apply the parking brake and stabilize the vehicle with a wheel chock(s) or deflate the tires. Put support material such as wooden blocks or utilize the Lift Airbag Equipment for rescue.

WARNING

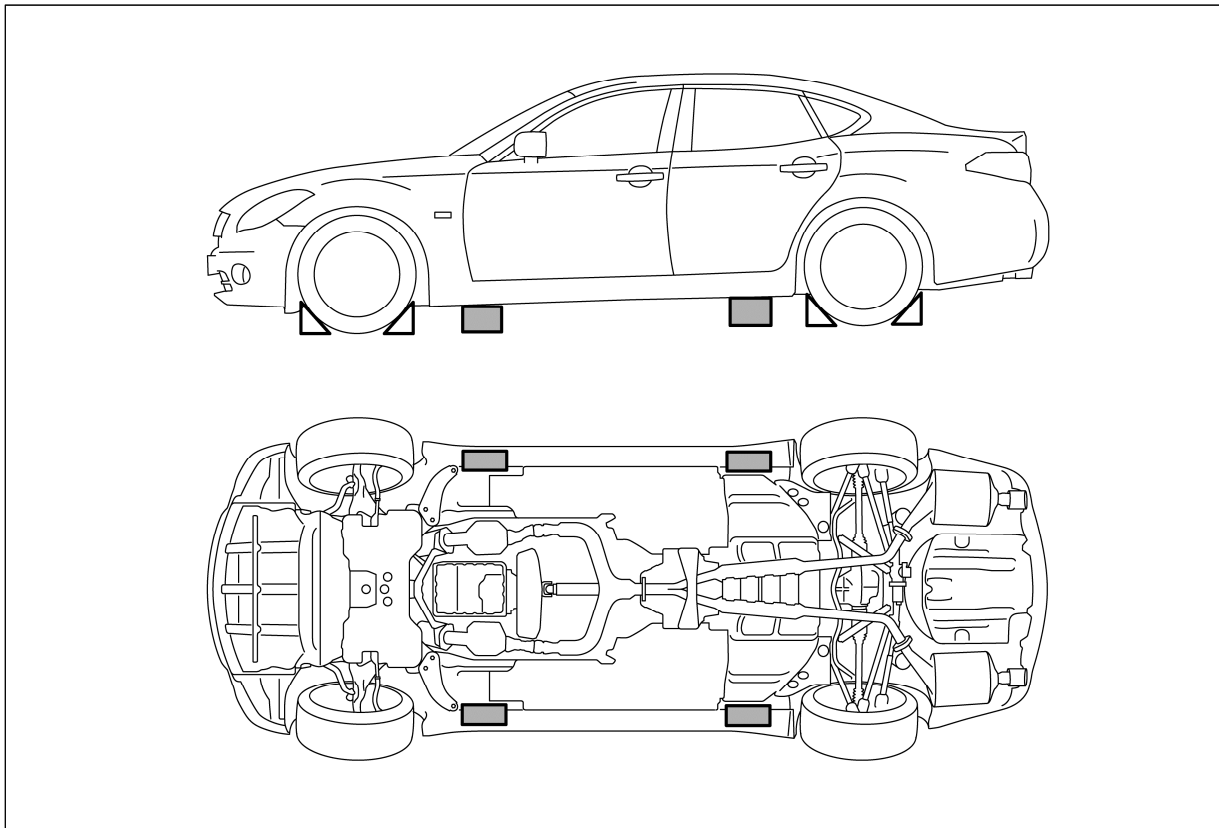

- To avoid electrical shock, do not put the Lift Airbag Equipment for rescue and wheel chock(s) under the high voltage components and harnesses.



3-3 How to Handle a Damaged Vehicle at an Accident Scene

3-3.1 Water Submersion

WARNING

-  The ignition switch of the submerged vehicle must be turned OFF first, if possible. Then the vehicle must be completely out of the water and drained to avoid electrical shock.
-  Wear appropriate PPE and remove/drain water before removing the service plug when working on a vehicle after a fire or submersion to avoid electrical shock.
-  If the vehicle is in the water, to avoid electrical shock do not touch the high voltage components, harnesses or service plug.

3-3.2 Vehicle Fire

WARNING

In the case of extinguishing a fire with water, large amounts of water from a fire hydrant (if possible) must be used. DO NOT extinguish fire with a small amount of water. Small amounts of water will make toxic gas produced by a chemical reaction between the Li-ion battery electrolyte and water.

CAUTION

In the event of a small fire, a Type ABC fire extinguisher may be used for an electrical fire caused by wiring harnesses, electrical components, etc. or oil fire.



In case of vehicle fire, contact fire department immediately and extinguish the fire if possible. If you must walk away from the vehicle, notify an appropriate responder or a rescue person of the fact that the vehicle is a hybrid vehicle that contains a high voltage system and warn all others.

3-3.3 High Voltage System Shut-Down Procedure

Shut down the high voltage system according to vehicle damage level. Any of the following procedures can shut down the high voltage system. The first response operation should be done after shutting down the high voltage system.

If the vehicle is heavily damaged, for example the Li-ion battery is deformed, broken or cracked, appropriate PPE must be used and the Li-ion battery and high voltage components must not be touched.

DANGER

-  Failure to properly shut down the high voltage system before the Emergency Response Procedures are performed will result in serious injury or death from electrical shock. To prevent serious injury or death, DO NOT touch high voltage harnesses or components with bare hands.
-  When contact with high voltage components or high voltage harnesses is unavoidable, or when there is risk of such contact, be sure to wear appropriate PPE.

WARNING

-  The vehicle contains parts that contain powerful magnets. If a person who is wearing a pacemaker or other medical device is close to these parts, the medical device may be affected by the magnets. Such persons must not perform work on the vehicle.
- Be sure to check the READY indicator (1) in the instrument cluster, and verify that the READY indicator is off and the high voltage system is stopped.

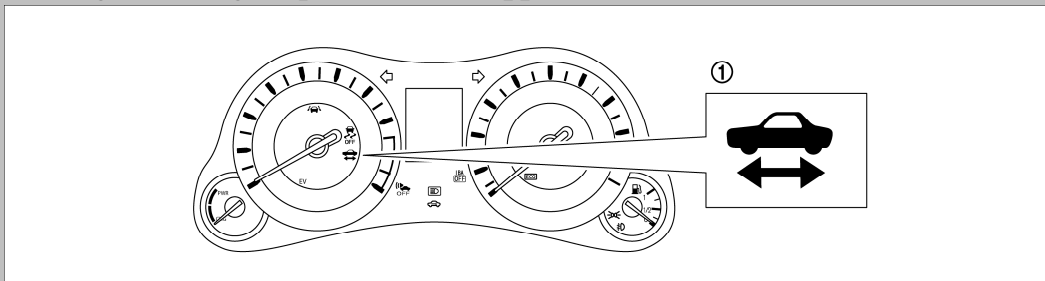

- After the high voltage system is shut down, please wait for ten (10) minutes for complete discharge of the high voltage condenser. While waiting, do not operate any vehicle functions.
- The high voltage full discharge takes ten (10) minutes, but after five (5) minutes the voltage has dropped below 60V.
- Shut down the high voltage and remove the 12V battery negative (-) terminal and wait for three (3) minutes to discharge the air bag condenser. Even though the 12V battery negative (-) is disconnected, the Supplemental Restraint System (SRS) air bag maintains voltage for three (3) minutes. There is a possibility of sudden SRS air bag inflation due to harness short circuit or damage and it may cause serious injuries.

 **CAUTION**

Because DC/DC converter keep operation even if remove the 12 V battery negative terminal, 12V can not be shut down. The high voltage system also can not shut down.

Before disconnecting the 12V battery terminal, if necessary, lower the windows, adjust the steering column, adjust the seats, unlock the doors, open the trunk, etc. as required. Once the 12V battery is disconnected, power controls will not operate.

Refer to the following chart to determine which shut-down procedure should be used according to the vehicle damage.

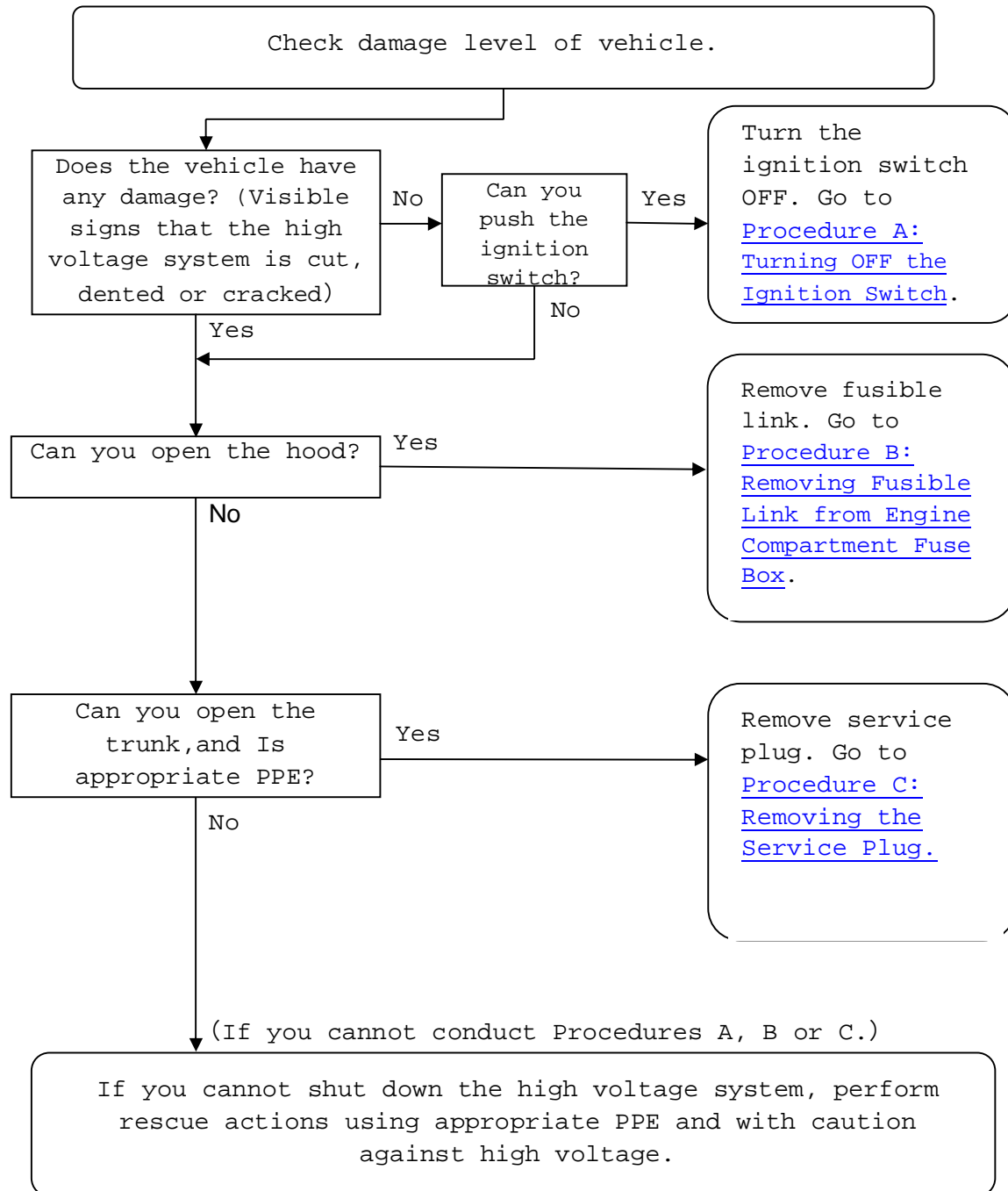

Procedure A: Turning OFF the Ignition Switch

1. Check the READY indicator (1) status in the instrument cluster. If it is on, the high voltage system is active.
2. Place the shift selector in the Park (P) position.
3. Push the ignition switch (2) once to turn OFF the high voltage system. Then verify whether the READY indicator (1) is off. If the READY indicator does not turn off, either of the below methods can shut off the high voltage system:
 - a. When the hood can be opened, Procedure B.
 - b. When the hood cannot be opened, Procedure C.

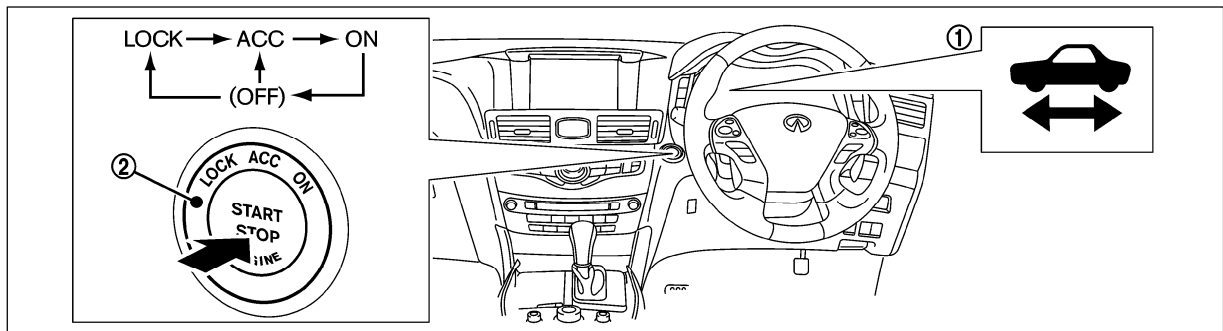

4. If possible, keep the INFINITI Intelligent Key™ at least 5 meters (16 feet) away from the vehicle.

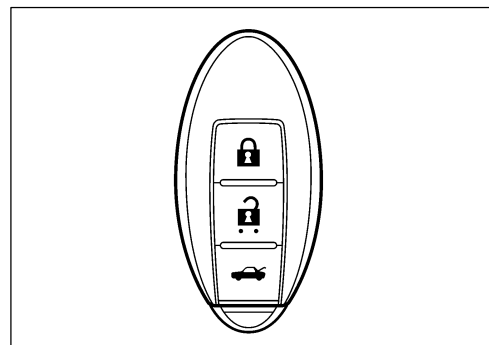

5. If possible, Open the trunk (1). The trunk can be opened with the push-button switch on the lower RH side of the instrument panel or on Q70 / M35h with the mechanical key (2) housed inside the INFINITI Intelligent Key™.
 6. For Q70 / M35h open service access cover-1 (3). For Q50, remove access cover on lower left hand side.
 7. If possible, Disconnect negative (-) battery cable (4) and cover it with insulated tape.
- Note; If impossible to disconnect negative (-) battery cable, 12V can not be shut down. There is a possibility of sudden SRS air bag inflation due to harness short circuit or damage and it may cause serious injuries.
8. Wait ten (10) minutes for complete discharge of the high voltage condenser after the battery cable has been disconnected.
 9. Perform the first response action.

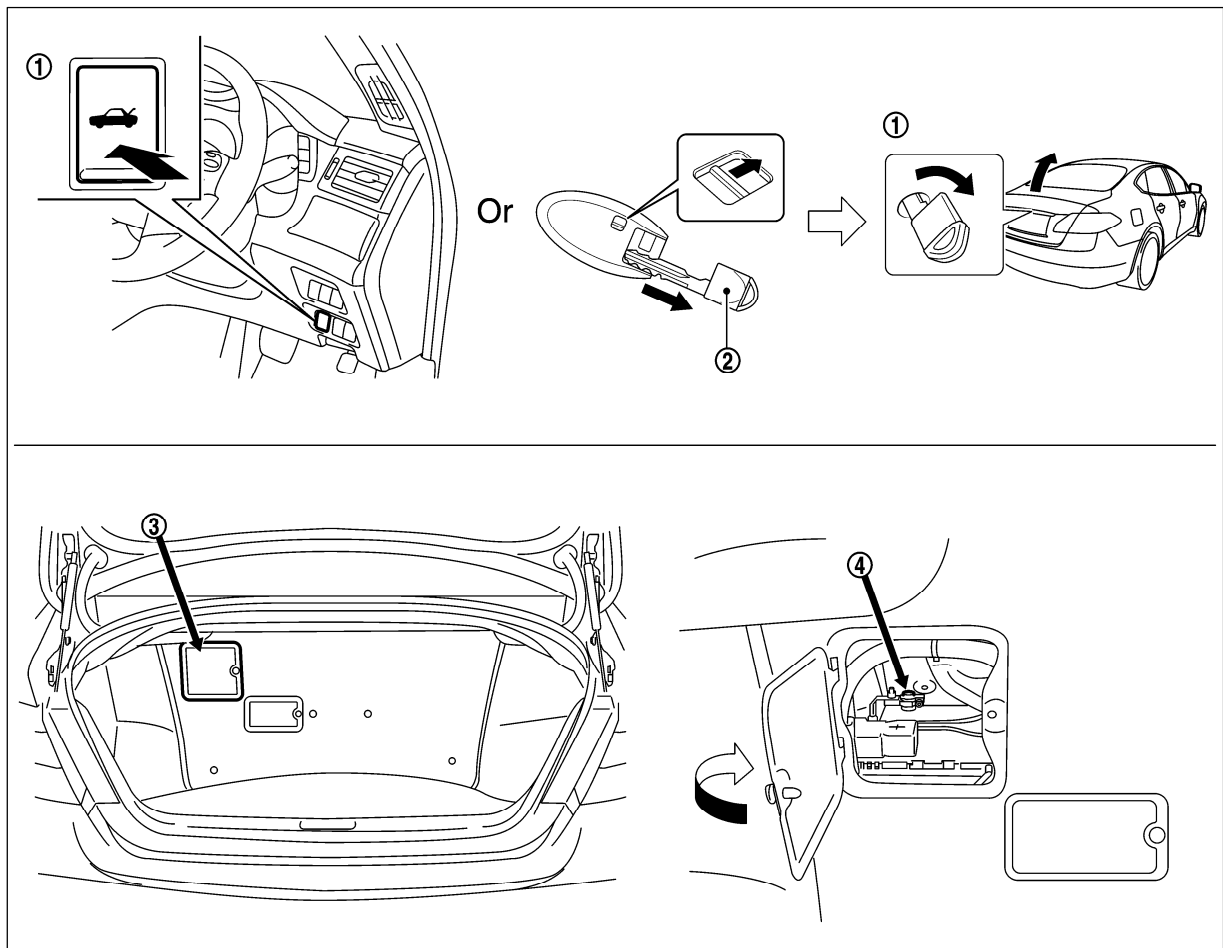

Procedure B: Removing Fusible Link from Engine Compartment Fuse Box

⚠ WARNING

⚠ To avoid unintended installation and risk of electrical shock and severe personal injury or death, the rescuer should carry the fusible link on his/her person and cover the fuse box with insulated tape while work is in progress.

NOTE:

Before removing any fuses, if necessary, lower the windows, adjust the steering column, adjust the seats, unlock the doors, etc. Once fuses are removed, power controls will not operate.

1. If possible, push ignition switch OFF.
2. Pull release handle (1) to open the hood.
3. Remove fuse box cover (2).
4. Remove fusible link (3).
5. If you cannot identify the fusible link (3), remove all fuses and fusible links in the fuse box.

Q70 / M35h:

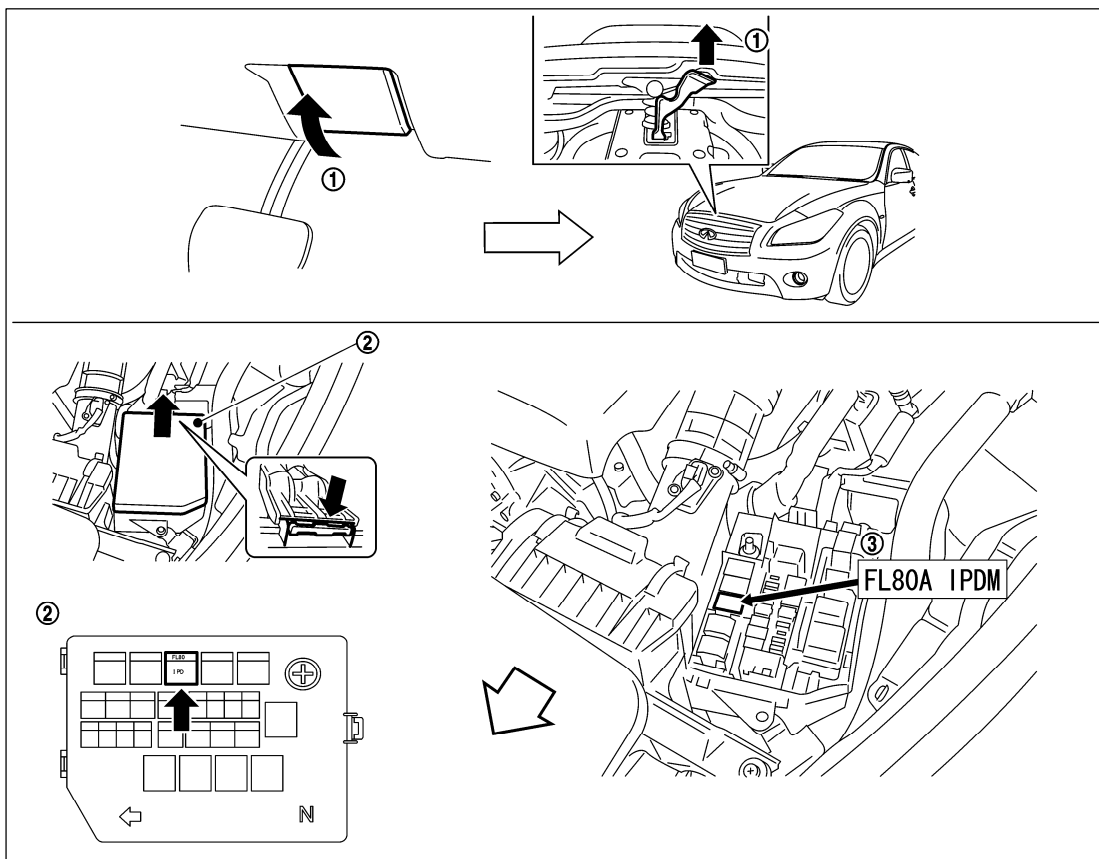

Q50:

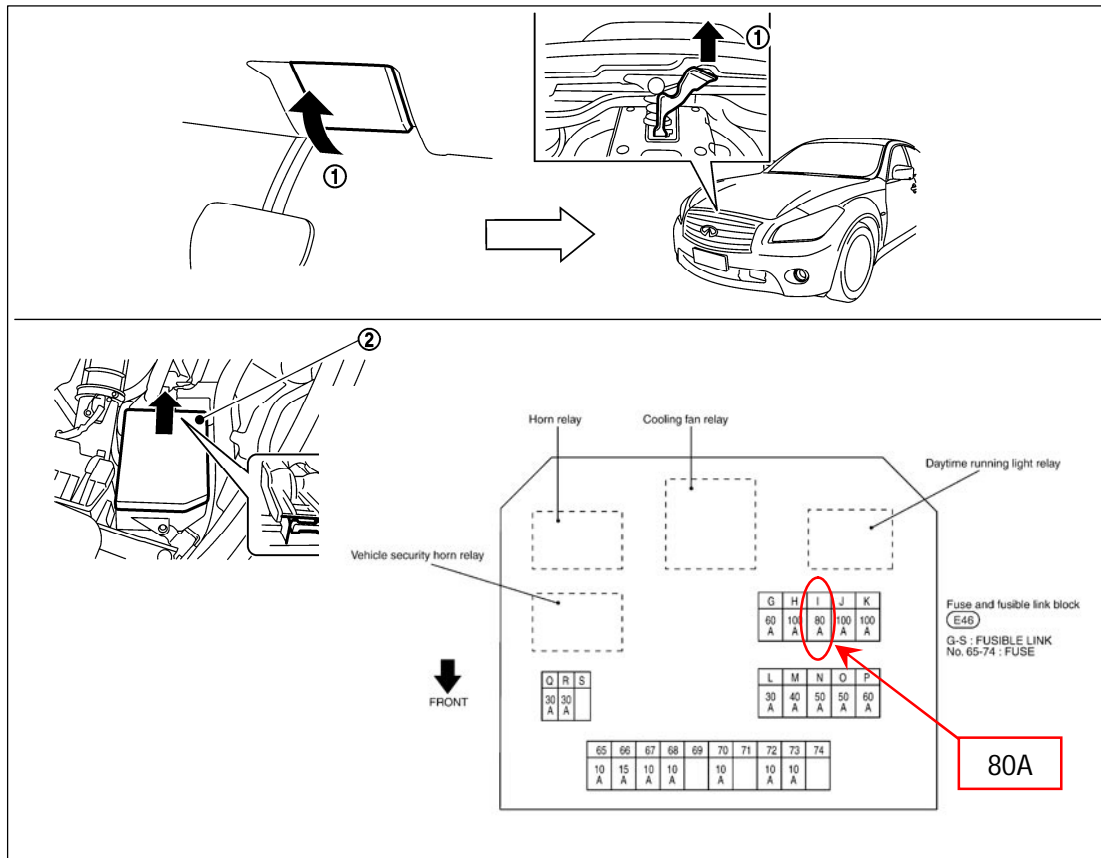

6. If possible, Open the trunk (1). The trunk can be opened with the push-button switch on the lower RH side of the instrument panel or with the mechanical key (2) housed inside the INFINITI Intelligent Key™.
7. Open service access cover-1 (3).
8. Disconnect negative (-) battery cable (4) and cover it with insulated tape.
Note; If impossible to disconnect negative (-) battery cable, 12V can not be shut down. There is a possibility of sudden SRS air bag inflation due to harness short circuit or damage and it may cause serious injuries.
9. Wait ten (10) minutes for complete discharge of the high voltage condenser after the fuses are pulled.

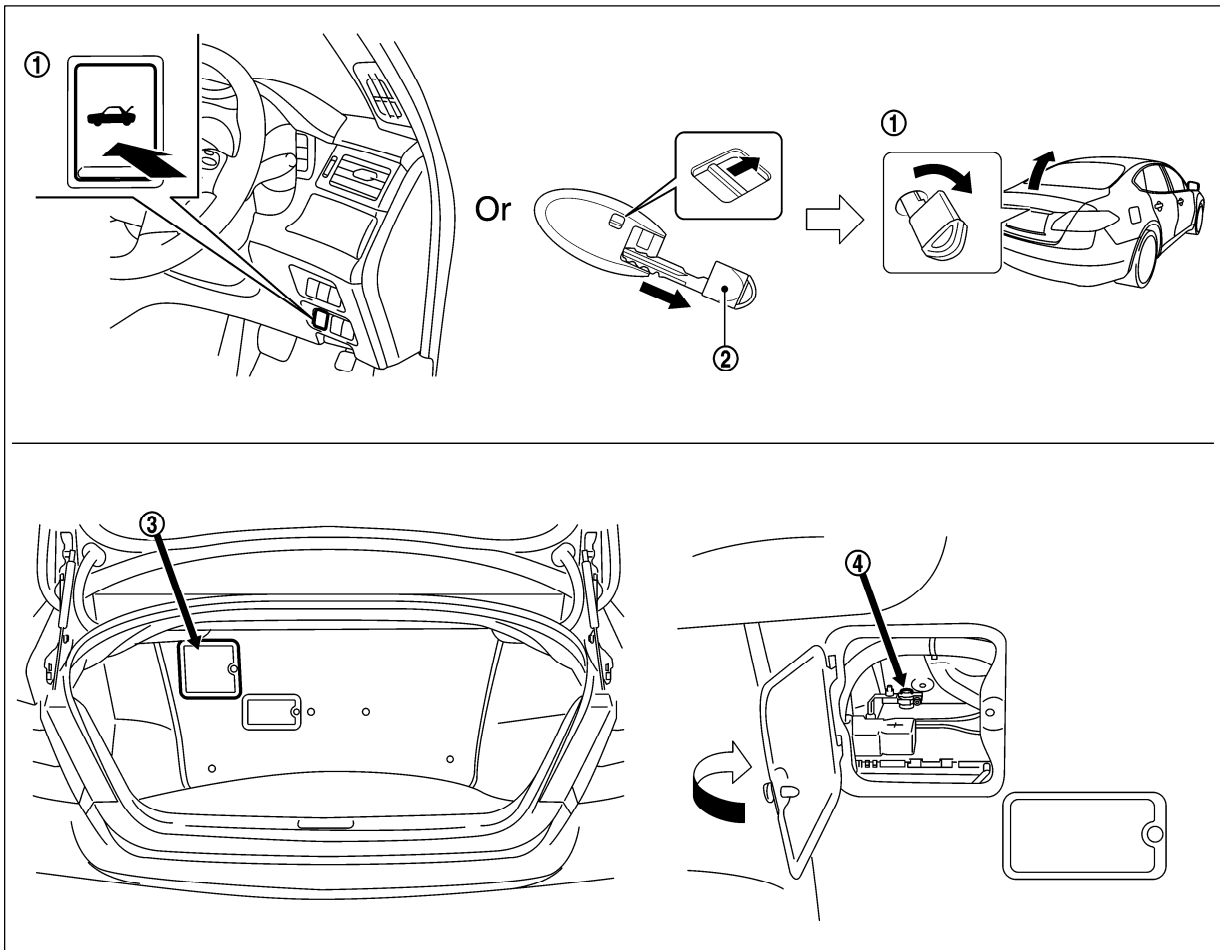

10. Perform the first response action.



NOTE: 12V battery for Q50 is located at lower left hand side of trunk.

Procedure C: Removing the Service Plug

DANGER

-  Do not remove the service plug without wearing appropriate PPE to help protect the responder from serious injury or death by electrical shock.
-  Immediately cover the service plug socket with insulated tape. To avoid electric shock, DO NOT touch the terminals inside the socket.

WARNING

-  To avoid unintended installation and risk of electrical shock and severe personal injury or death, the rescuer should carry the service plug on his/her person while work is in progress.

NOTE:

Before disconnecting the 12V battery terminal, if necessary, lower the windows, adjust the steering column, adjust the seats, unlock the doors, etc. Once 12V battery is disconnected, power controls will not operate.

1. Open the trunk (1). The trunk can be opened with the push-button switch on the lower RH side of the instrument panel or with the mechanical key (2) housed inside the INFINITI Intelligent Key™.
2. Open service access cover-2 (5).
3. Remove the service plug (6) by pressing the locking tab (a) and rotating the handle (b) fully outward (c). Using the handle, pull the service plug (d) completely out of its socket.
4. Wait ten (10) minutes for complete discharge of the high voltage condenser after the service plug has been removed.
5. If possible, disconnect negative (-) battery cable (4) and cover it with insulated tape.

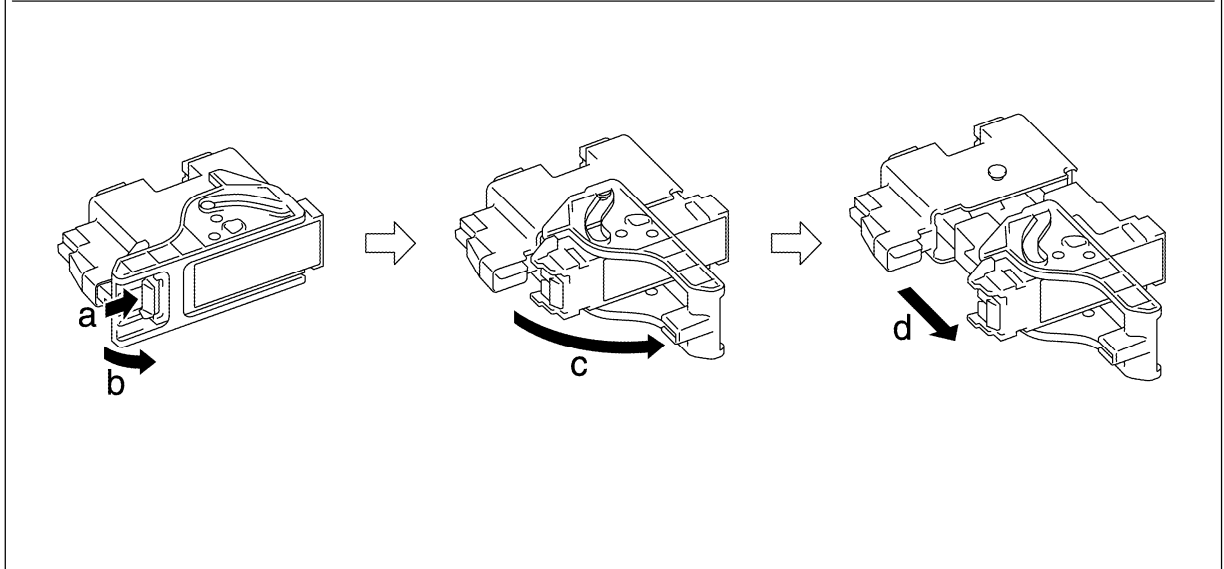
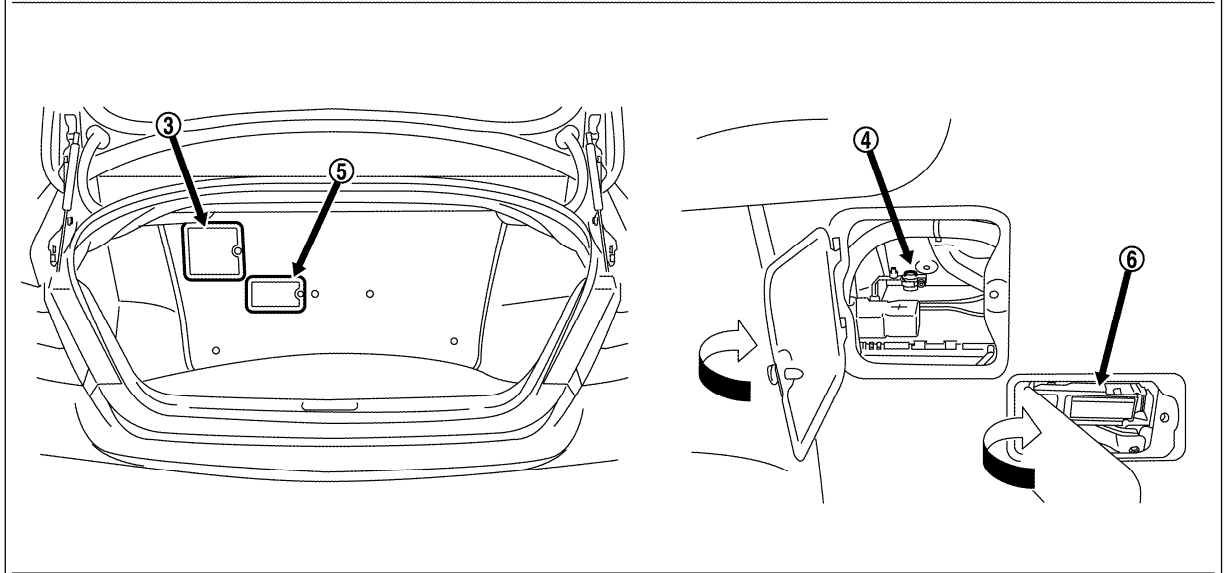
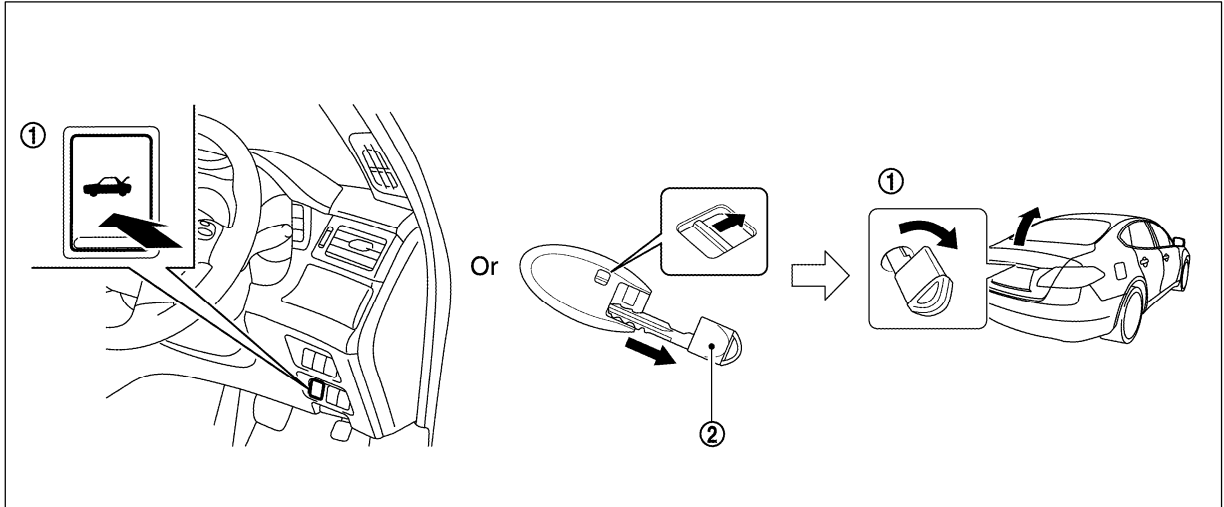

Note; If impossible to disconnect negative (-) battery cable, 12V can not be shut down. There is a possibility of sudden SRS air bag inflation due to harness short circuit or damage and it may cause serious injuries.

6. Perform the first response action.



3-3.4 Cutting the Vehicle Body

DANGER

-  Do not cut into high voltage related areas to avoid severe personal injury or death.
-  Do not cut into the Li-ion battery to avoid severe personal injury or death.
-  When removing parts, DO NOT touch the high voltage parts or the insides of the exposed orange-colored high voltage cables to avoid severe personal injury or death.

WARNING

-  Use the appropriate tools (for example, hydraulic cutter) when cutting the vehicle to help protect the first responder to avoid severe personal injury or death.
- Do not cut air bag parts to avoid unintended deployment of the air bags and the risk of severe personal injury or death.

If ten (10) minutes have passed since the rescuer shut down the high voltage system (refer to [3-3.3 High Voltage System Shut-Down Procedure](#)), then the rescuer can cut the vehicle except for the Li-ion battery. **DO NOT** cut the Li-ion battery due to possible electrocution risk and electrolyte solution leakage.

SRS Air Bag System Components Location

The SRS air bag system must not be cut as there is a risk of short circuit and unintentional deployment of the SRS. However, the vehicle can be cut (except inflators) under the following conditions:

- The front, side and curtain air bags have deployed.
- Three (3) minutes have passed after the 12V battery negative (-) cable has been disconnected.

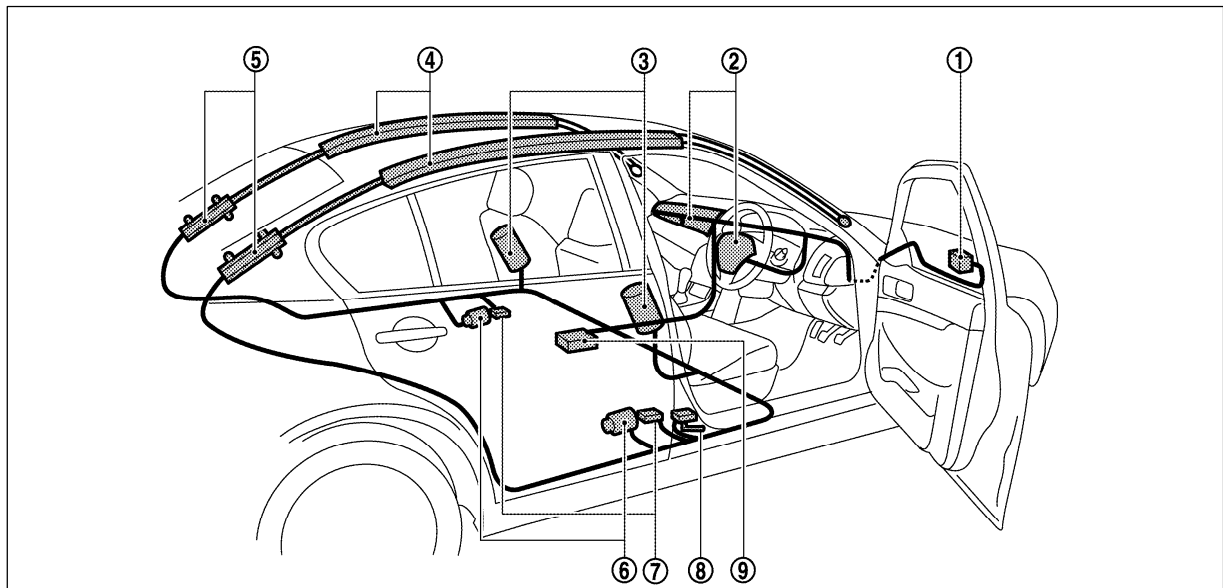

- | | | |
|--|---|--|
| 1. Crash zone sensor | 2. Supplemental front air bag modules | 3. Supplemental side air bag modules |
| 4. Supplemental curtain side-impact air bags | 5. Supplemental curtain side-impact air bag inflators | 6. Seat belts pretensioners retractors |
| 7. Satellite sensors | 8. Lap outer pretensioners (if equipped) | 9. Diagnosis sensor unit |

Vehicle Cut Sheet

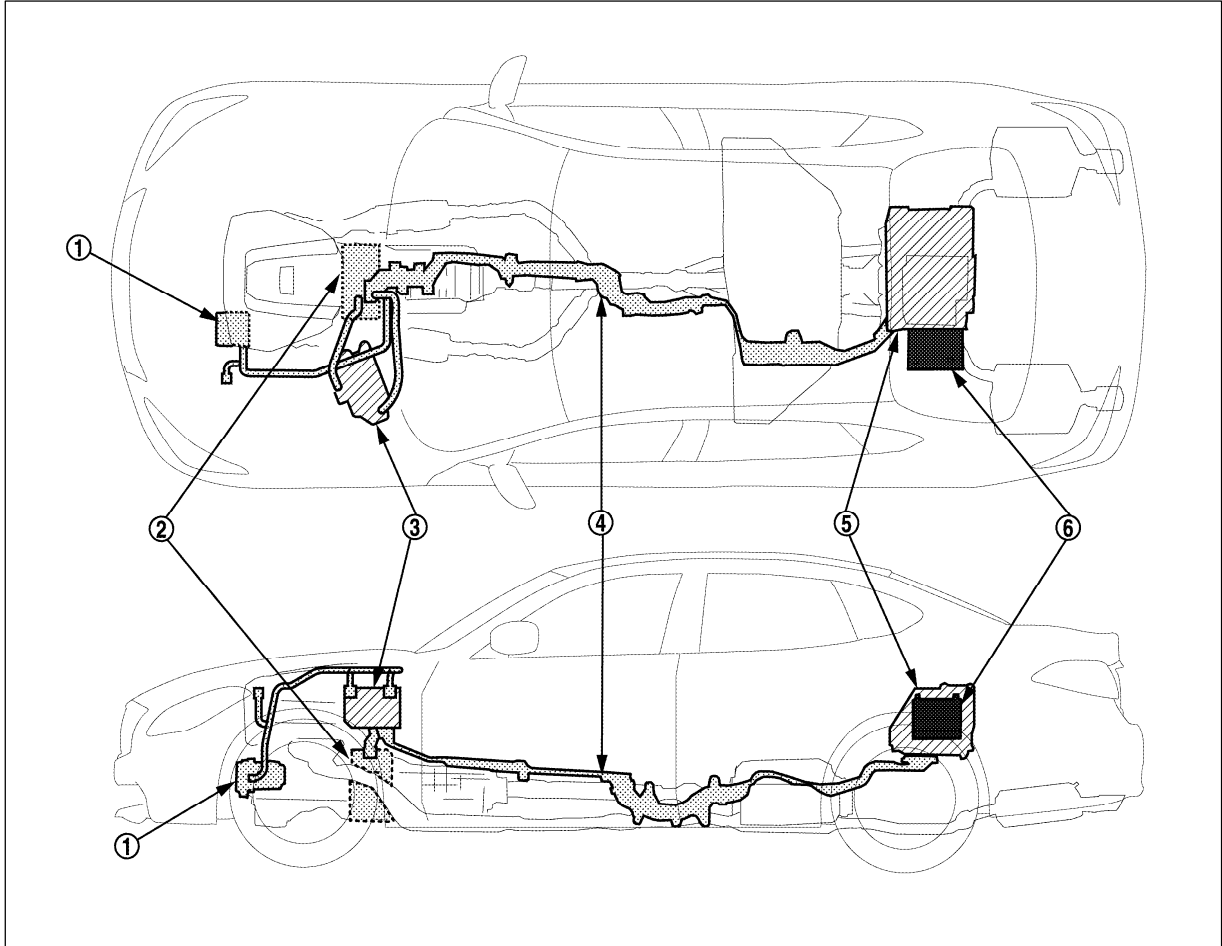

- | | | |
|--|----------------------------------|----------------------------|
| 1. Electric Compressor (for air conditioner) | 2. Traction Motor | 3. Traction Motor Inverter |
| 4. High voltage harness | 5. High voltage (Li-ion) battery | 6. 12V battery |

Key

- : High voltage component or line
- ▨ : NEVER CUT-High voltage component
- : 12V battery



DANGER



Never cut electrical storages/sources for any reason. Death or serious personal injury will result.

3-3.5 Li-ion Battery Damage and Fluid Leaks

Li-ion Battery Electrolyte Solution Characteristics:

- Clear in color
- Sweet odor
- Similar viscosity to water
- Skin irritant
- Eye irritant - If contact with eyes, rinse with plenty of water and see a doctor immediately.
- Highly flammable
- Electrolyte liquid or fumes that have come into contact with water vapors in the air will create an oxidized substance. This substance may irritate skin and eyes. In these cases, rinse with plenty of water and see a doctor immediately.
- Since the Li-ion battery is made up of many small sealed battery modules, electrolyte solution should not leak in large quantity.

NOTE:

Other fluids in the vehicle (such as washer fluid, brake fluid, coolant, etc.) are the same as those in a conventional internal combustion vehicle.

3-3.6 Accessing the Occupants

1. Remove windows
 - a. Perform window removal the same as a normal vehicle.
2. Remove doors
 - a. The doors are removable with hand tools or basic rescue tools such as electrical/hydraulic rescue tools. It may be easier to remove the doors by cutting door hinges.
3. Adjust steering wheel and front seat position (if necessary) as shown below:

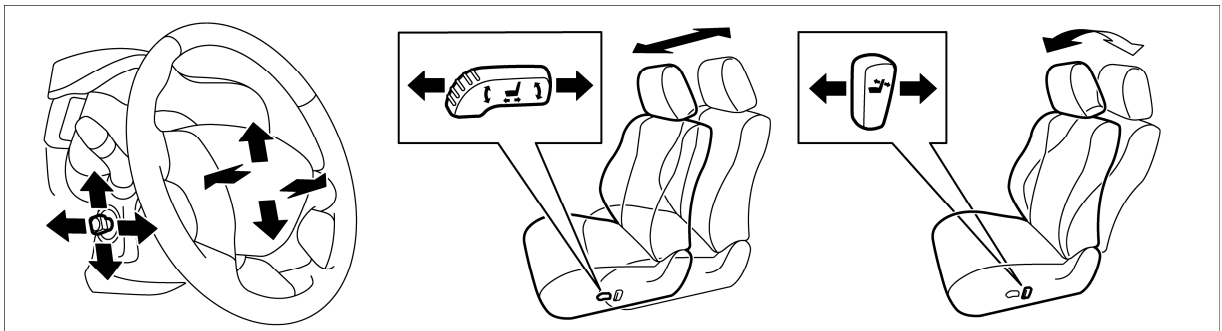

4. Remove front seat head restraint (if necessary).
The front seat head restraint can be removed by pressing the lock knob and pulling it up.

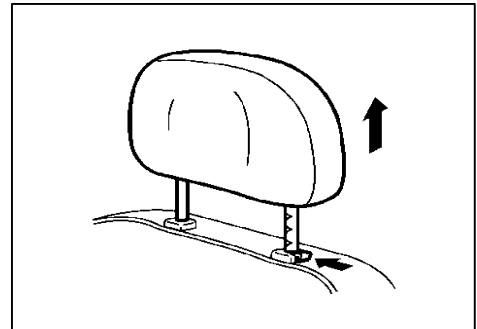

5. Unfasten the seat belt.
Seat belt can be unfastened by pressing the release button. If seat belt cannot be unfastened, cut it with a belt cutter.

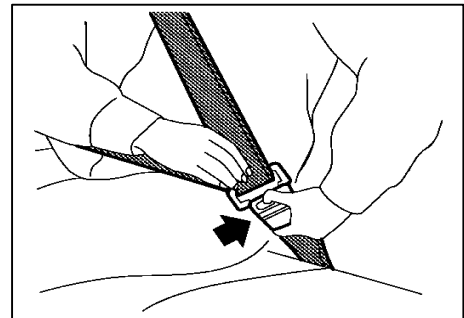

4. Roadside Assistance

4-1. Jump Starting

To start the hybrid system with a booster battery, the instructions and precautions below must be followed.

WARNING

If done incorrectly, jump starting can lead to a 12V battery explosion, resulting in severe personal injury or death. It could also damage your vehicle.

Jump starting provides power to the 12V system to allow the electrical systems to operate. The electrical systems must be operating to allow the Li-ion battery to be charged. Jump starting does not charge the Li-ion battery.

Discharged 12V battery may cause the following issues:

- The instrument cluster cannot be displayed while the ignition switch is turned ON. (The hybrid system cannot start.)
- Headlamps, horn, etc. are weak.

WARNING

-  To avoid electrical shock, the high voltage Li-ion battery CANNOT be jump started.
- Explosive hydrogen gas is always present in the vicinity of the 12V battery. Make sure the vent tube is mounted.
- Do not allow battery fluid to come into contact with eyes, skin, clothing or painted surfaces. Battery fluid is a corrosive sulfuric acid solution that can cause severe burns. If the fluid comes into contact with anything, immediately flush the contacted area with water and contact a doctor.
- The booster battery must be rated at 12 volts. Use of an improperly rated battery can damage the vehicle.
- Whenever working on or near a 12V battery, always wear suitable eye protectors (for example, goggles or industrial safety spectacles) and remove rings, metal bands, or any other jewelry. Do not lean over the 12V battery when jump starting.
- Do not attempt to jump start a frozen battery. It could explode and cause serious injury.
- HYBRID is equipped with an automatic cooling fan. It could come on at any time. Keep hands and other objects away from it.
- Always follow the jump starting instructions below. Failure to do so could result in damage to the DC/DC converter and cause personal injury.

4-1.1 Jump Starting Procedures

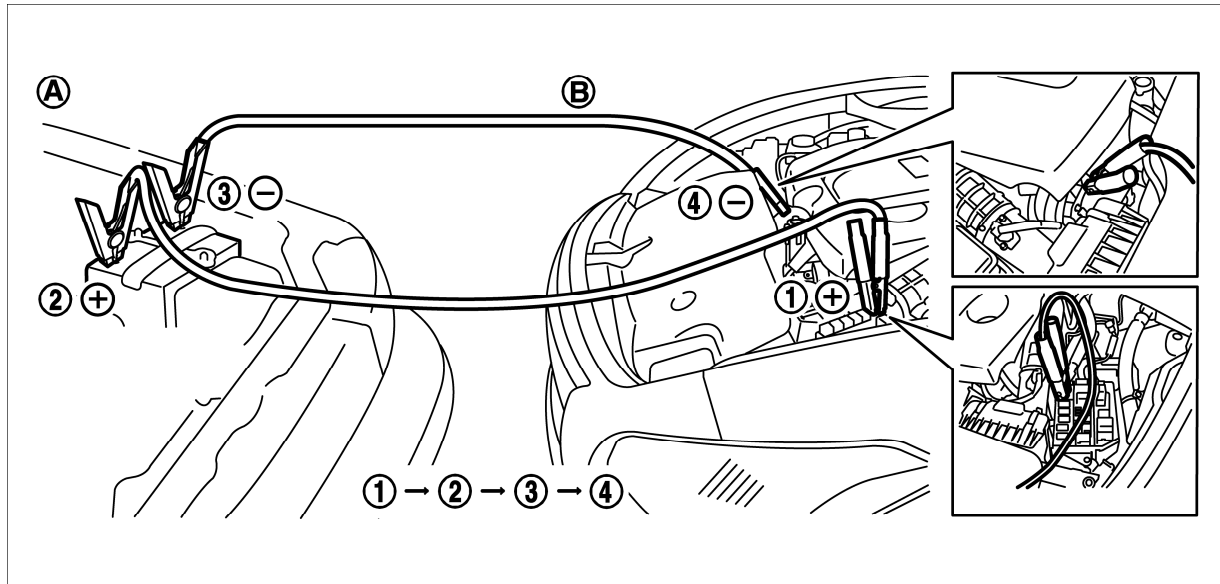

NOTE:

Jumper cable connections under the hood of the HYBRID are not connected directly to a battery. They are connected to chassis ground and a fuse box terminal. Refer to the following instructions and the above illustration.

1. If the booster battery is in another vehicle (A), position the two vehicles (A and B) to bring the 12V battery and fuse box into close proximity to each other.

DO NOT allow the two vehicles to touch.

2. Apply the parking brake. Move the selector lever the P (Park) position. Switch off all unnecessary electrical systems (headlights, heater, air conditioner, etc.).
3. Remove fuse box cover on the HYBRID and connect jumper cables in the sequence as illustrated (1→2→3→4).

For models with a steering wheel lock mechanism:

If the 12V battery is disconnected or discharged, the steering wheel will lock and cannot be turned. Supply power using jumper cables before pushing the ignition switch and disengaging the steering lock.

⚠ CAUTION

- Always connect positive (+) to positive (+) and negative (-) to body ground (for example, as illustrated), not to the 12V battery.
- Make sure the jumper cables do not touch moving parts in the motor compartment and that the cable clamps do not contact any other metal.
- If the hybrid system does not start right away, push the ignition switch to the OFF position and wait ten (10) seconds before trying again.

4. Start the engine of the booster vehicle (A) and let it run for a few minutes.
5. Start the hybrid system of the vehicle being jump started (B).
6. After starting the hybrid system, carefully disconnect the negative cable and then the positive cable (4→3→2→1).
7. Reinstall the fuse box cover.

NOTE:

If it is not possible to turn the hybrid system ON by following this procedure, contact an INFINITI retailer immediately.

4-2 Towing

4-2.1 Vehicle Specifications

	Q70 / M35h	Q50
Length	4,945 mm	4,800 mm
Width	1,845 mm	1,820 mm
Overall Height	1,500 mm	1,455 mm
Wheelbase	2,900 mm	2,850 mm
Minimum ground clearance	151.2 mm	126 mm
Overall vehicle weight	About 1,900kg (4200 lbs.)	1871 kg (unladen)
Front approach angle	16.1°	16.3°
Rear departure angle	16.5°	17.1°

4-2.2 Towing Guidelines

INFINITI strongly recommends that HYBRID be towed with a flatbed truck.

WARNING

If this vehicle needs to be towed, do it with the rear wheels raised. If the rear wheels are on the ground when towing, the electric motor may generate electricity. This may damage the hybrid system components and cause a fire.

NOTE: Q50 Hybrid AWD cannot be towed with ANY wheels on the ground.

CAUTION

- When towing, make sure that the transmission, axles, steering system and powertrain are in working condition. If any unit is damaged, dollies must be used.
- Always attach safety chains before towing.
- Never tow automatic transmission models with the rear wheels on the ground (forward or backward), as this may cause serious and expensive damage to the transmission. If it is necessary to tow the vehicle with the front wheels raised, always use towing dollies under the rear wheels.
- When towing rear wheel drive models with the front wheels on the ground or on towing dollies: Push the ignition switch to the ACC or ON position, and secure the steering wheel in a straight ahead position with a rope or similar device. For models with a steering wheel lock mechanism: Never secure the steering wheel by selecting the LOCK position. This may damage the steering lock mechanism.
- Transport the vehicle after turning the ignition switch OFF.
- Tow chains or cables must be attached only to the vehicle recovery hook or main structural members of the vehicle. Otherwise, the vehicle body will be damaged.
- Do not use the vehicle tie down hook to free a vehicle stuck in sand, snow, mud, etc.
- Never tow a vehicle using the rear vehicle tie down hook or front recovery hook.
- Always pull the cable straight out from the front of the vehicle. Never pull on the vehicle at an angle.
- Pulling devices should be routed so they do not touch any part of the suspension, steering, brake, high voltage or cooling systems.
- Pulling devices such as ropes or canvas straps are not recommended for use in vehicle towing or recovery.

Perform vehicle towing by holding up drive (rear) wheels (ALL on Q50 Hybrid AWD) or on flatbed in order to prevent secondary damage from voltage generated by the motor (built-into the transmission). In

addition, push the ignition switch OFF when towing the vehicle. Refer to the following illustration:

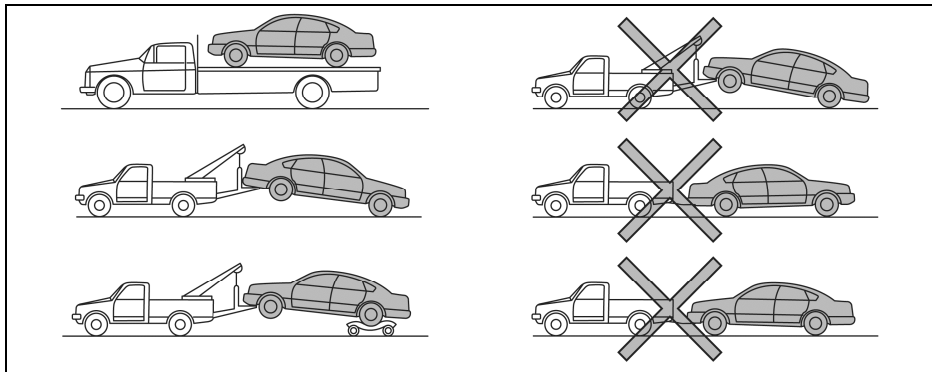

4-2.3 Use of Vehicle Equipped Hook for Recovery Operations

WARNING

-  If any of the following conditions exist:
 - Damage is observed in the high voltage components or harnesses.
 - Damage is observed in the driveline, brake, suspension, tires, etc.
 - Fluid leakage is observed.

Turn the ignition switch OFF and pull the service plug using appropriate PPE. Refer to [Procedure C: Removing the Service Plug](#). Transport the vehicle with a flatbed truck to avoid electrical shock which may result in severe personal injury or death.

CAUTION

The steering lock will not engage when the transmission is in the Neutral (N) position. However, if the 12V battery is dead or is disconnected while the transmission is in the Park (P) position, the steering lock cannot be released. To avoid vehicle damage this case, temporarily connect a booster battery to the vehicle then push the ignition switch to the ACC or ON position to release the steering lock mechanism. Refer to [4-1. Jump Starting](#) for information about connecting a booster battery.

Front:

1. Get the vehicle recovery hook (1) from the tool kit pouch in the trunk. Remove the recovery hook cover (2) from the front bumper fascia.

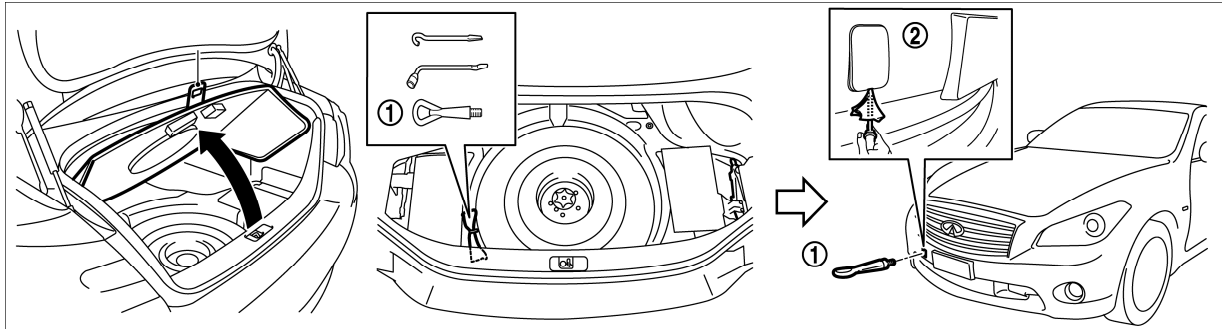

2. Securely install the recovery hook as illustrated.

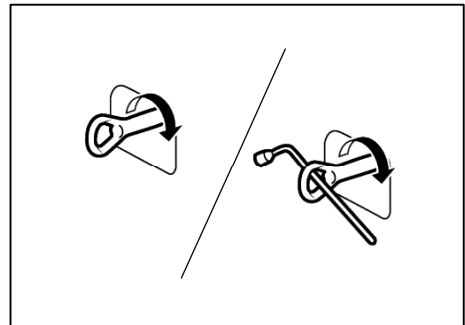

3. Recover the vehicle.
4. Make sure that the vehicle recovery hook is properly secured in its original position after use and the recovery hook cover has been reinstalled properly.

Rear Tie Down Hook:

Do not use the rear tie down hook for towing or vehicle recovery.

4-3 Storing the Vehicle

If the HYBRID needs to be stored, put a sign on the vehicle indicating it is a hybrid vehicle with high voltage dangers. For example, refer to [5. Storing the Vehicle](#).

4-4 Jack, Tools and Spare Tire

The jack (1), tools (2) and spare tire (3) are located in the trunk.

Note: Q50 does not have a spare tire.

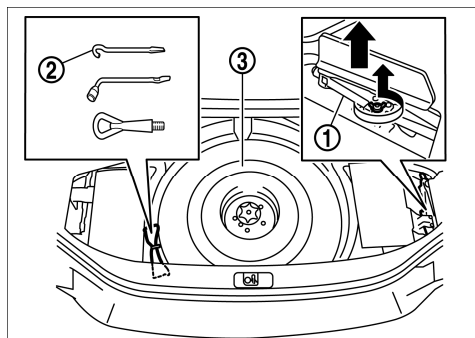

4-5 Shift Selector Lever Lock Release

If the 12V battery is low or discharged, the selector lever cannot be moved from the Park (P) position. If a booster battery is not available, the selector lever lock can be manually released. To manually release the selector lever lock, perform the following procedure:

1. Push the ignition switch to the LOCK or OFF position.
2. Apply the parking brake.
3. Remove the shift lock cover (A) using a suitable tool.
4. Push down the shift lock (B) as shown in the illustration.
5. Push the selector lever button (C) and move the selector lever to the Neutral (N) position (D) while holding down the shift lock.

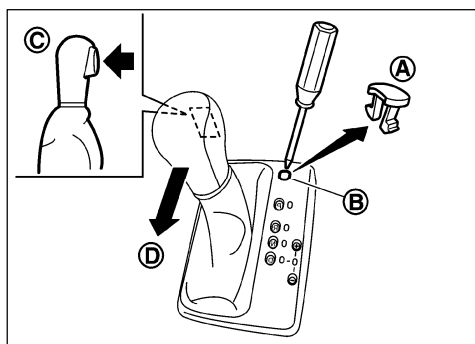

4-6 Opening the Fuel Filler Door

To open the fuel filler door it must first be unlocked. The fuel filler door can be unlocked by any of the following operations:

- Push the outside door handle request switch while carrying the INFINITI Intelligent Key™.
- Push the UNLOCK button on the INFINITI Intelligent Key™.
- Insert the mechanical key into the door lock cylinder and turn it to the rear of the vehicle.

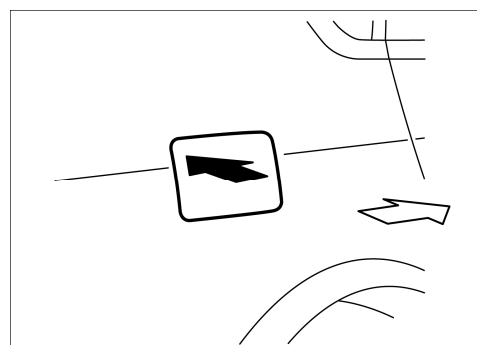

- Push the power door lock switch to the UNLOCK position.

When unlocked, the fuel filler lid can be opened by pressing its upper LH corner area as illustrated.

5. Storing the Vehicle

If the HYBRID needs to be stored or left unattended, put a sign on the vehicle indicating it is a hybrid vehicle with high voltage dangers. For example:

Person in charge: _____
**DO NOT TOUCH!
IN PROGRESS.
HIGH VOLTAGE REPAIR
DANGER:**

**DANGER:
HIGH VOLTAGE REPAIR
IN PROGRESS.
DO NOT TOUCH!**

Person in charge: _____

Copy this page and put it after folding on the roof of the vehicle in service.



I N F I N I T I .®

© 2011 NISSAN MOTOR CO.,LTD.

All rights reserved.

This document may not be altered without the written permission of NISSAN MOTOR CO.,LTD